



INSTRUCTION DE MONTAGE
MONTAGEANLEITUNG
INSTRUCTIONS FOR ASSEMBLY
INSTRUCCIONES DE MONTAJE

SAF-TELESCOPIC

NM_SAFTL_002

Poids maximal des panneaux Maximales Gewicht Maximum weight Peso máximo	120 KG 265 lbs.
Epaisseur des panneaux Ladendicke Shutter thickness Espesor de las contraventanas	45 mm 1 ³ / ₄ "
Largeur maximale des panneaux Maximale Flügelbreite Maximum panel width Ancho máximo de panel	700 - 1500 mm 27 " - 59 "

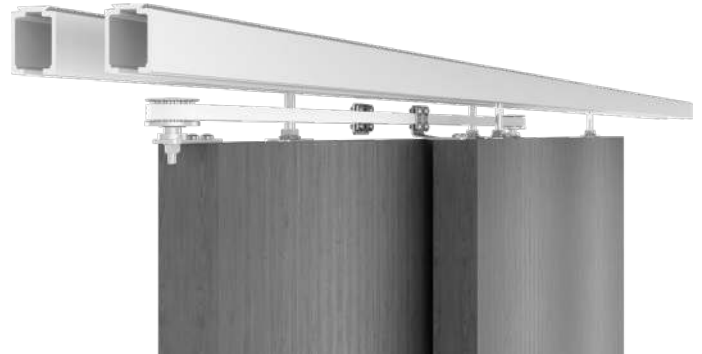

COMPOSITION - ZUSAMMENSETZUNG - COMPOSICIÓN

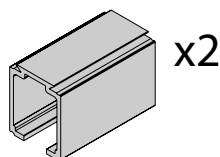

11312/...

x2

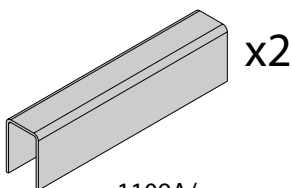

1109A/...

x2

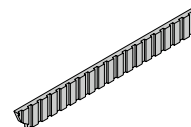

10172/...

SAF121-TL2

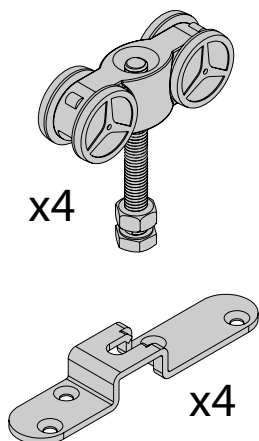

x4

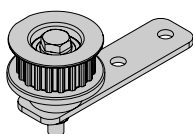

x2

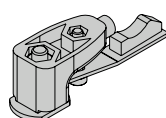

x2

1102TL2

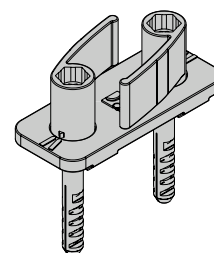
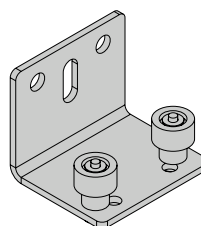

10190S22

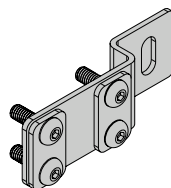
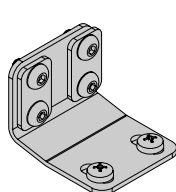

CONDITIONS DE POSE / MONTAGEBEDINGUNGEN / INSTALLATION REQUIREMENTS / CONDICIONES DE COLOCACION:

- Produit destiné à une utilisation en intérieur / Dieses Produkt ist nur für Innenanwendung geeignet / For indoor use only / Producto para utilización en interior
- Ne pas installer dans des endroits humides / Nicht in feuchten Atmosphären verwenden / Do not install in humid places / No instalar en lugares húmedos
- Le montage doit être effectué par des monteurs qualifiés / Die Montage muss von qualifizierten Handwerkern geführt werden / Installation must be performed by skilled personnel / el montaje tiene que hacerse por instaladores cualificados

DIMENSIONS / MASSE / SIZING / DIMENSIONES (mm):

- Epaisseur panneau / Paneelstärke / Panel thickness / Grueso del panel: **45 mm**
- Poids panneau / Paneelgewicht / Panel weight / Peso panel: **120 Kg MAX**

45 mm - 1 3/4"

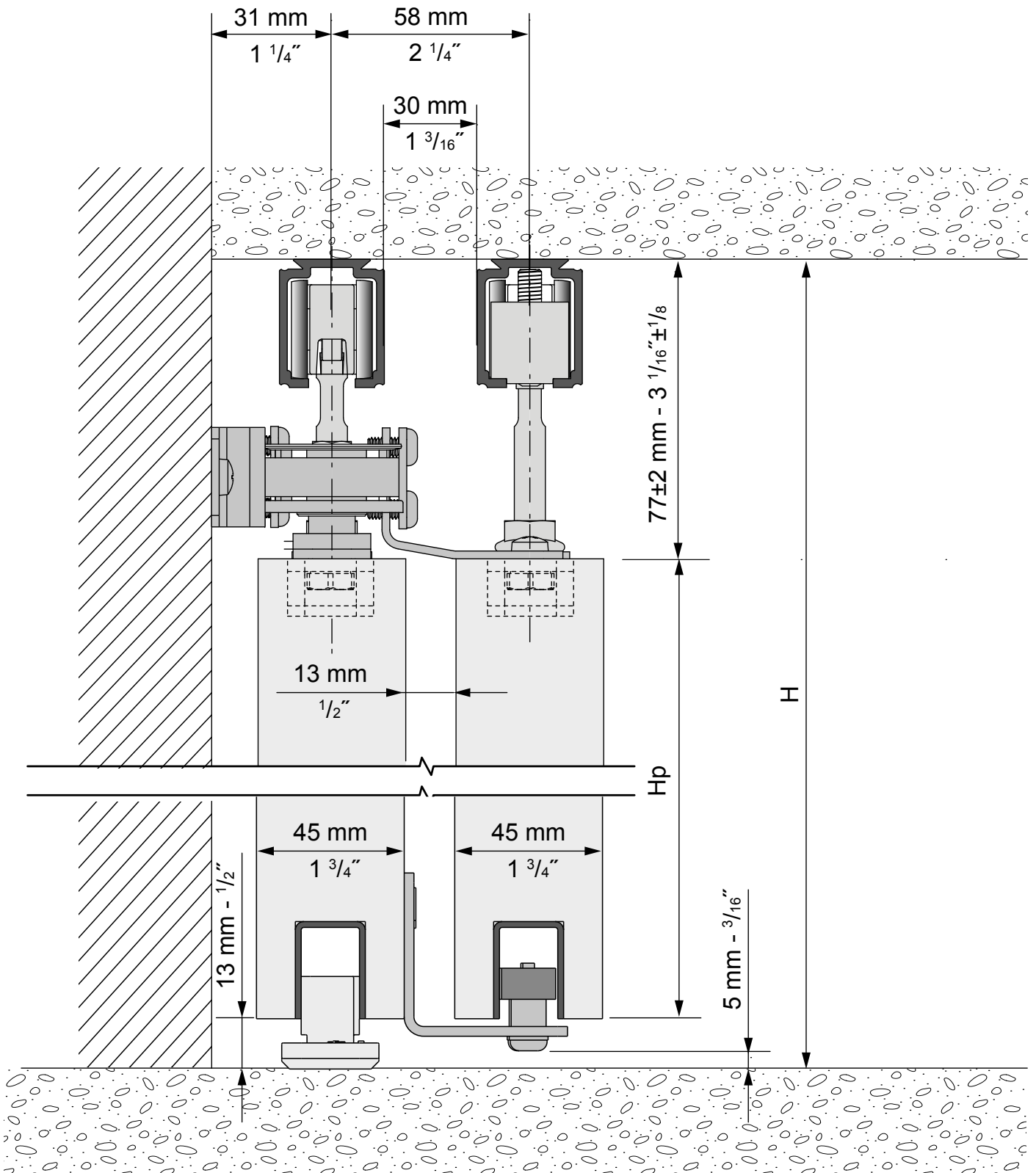

H = Hauteur de baie
 Opening height
 Öffnungshöhe
 Altura de luz

Hp = Hauteur panneaux
 Door height
 Schiebetürhöhe
 Altura de panel

$$H_p = H - 90 \text{ mm} = \text{_____ mm}$$

$$H_p = H - 3 \frac{1}{2} \text{ \"} = \text{_____ \"}$$

PLANIFICATION - PLANUNG - PLANNING - PLANIFICACIÓN



$R = 90 \text{ mm}$
 $3 \frac{1}{2}''$

$L_p = \frac{(2 \times R) + LO}{2} = \text{_____ mm}$

$LR = LO + L_p = \text{_____ mm}$

$700 \leq L_p \leq 1500$
 $27'' \leq L_p \leq 59''$
 $LR \leq 3000$
 $LR \leq 118''$

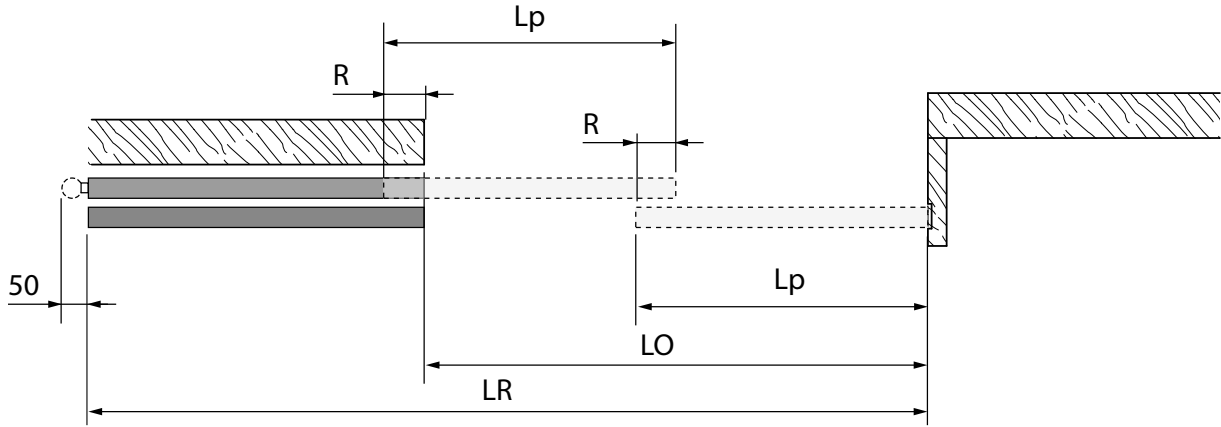

$R = 90 \text{ mm}$
 $3 \frac{1}{2}''$

$L_{p1} = \frac{(2 \times R) + (LO - P)}{2} = \text{_____ mm}$

$P = 90 \text{ mm}$
 $3 \frac{1}{2}''$

$L_{p2} = L_{p1} + P = \text{_____ mm}$

$LR = LO + L_{p1} = \text{_____ mm}$

$700 \leq L_{p1} \leq 1500$
 $27'' \leq L_{p1} \leq 59''$
 $LR \leq 3000$
 $LR \leq 118''$

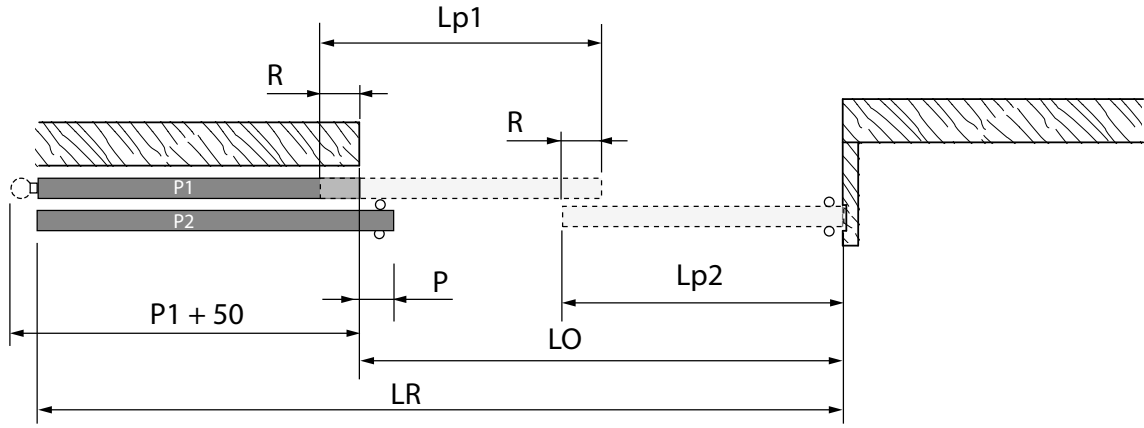

- LO** = Largeur de baie / Opening width / Öffnungsbreite / Ancho de luz
- Lp** = Largeur panneaux / Door width / Schiebetürbreite / Ancho de panel
- LR** = Longueur de rails / Length of tracks / Länge von Laufshienen / Longitud de los perfiles
- R** = Recouvrement / Door overlap / Türübershneidung / Recubrimiento
- P** = Poignée baton / Sliding door handle / Schiebetürgriffe / Tirador

PRÉPARATION DES PANNEAUX - PANELS PREPARATION
 VORBEREITUNG DER FLÜGEL - PREPARACIÓN DE LAS HOJAS

1.

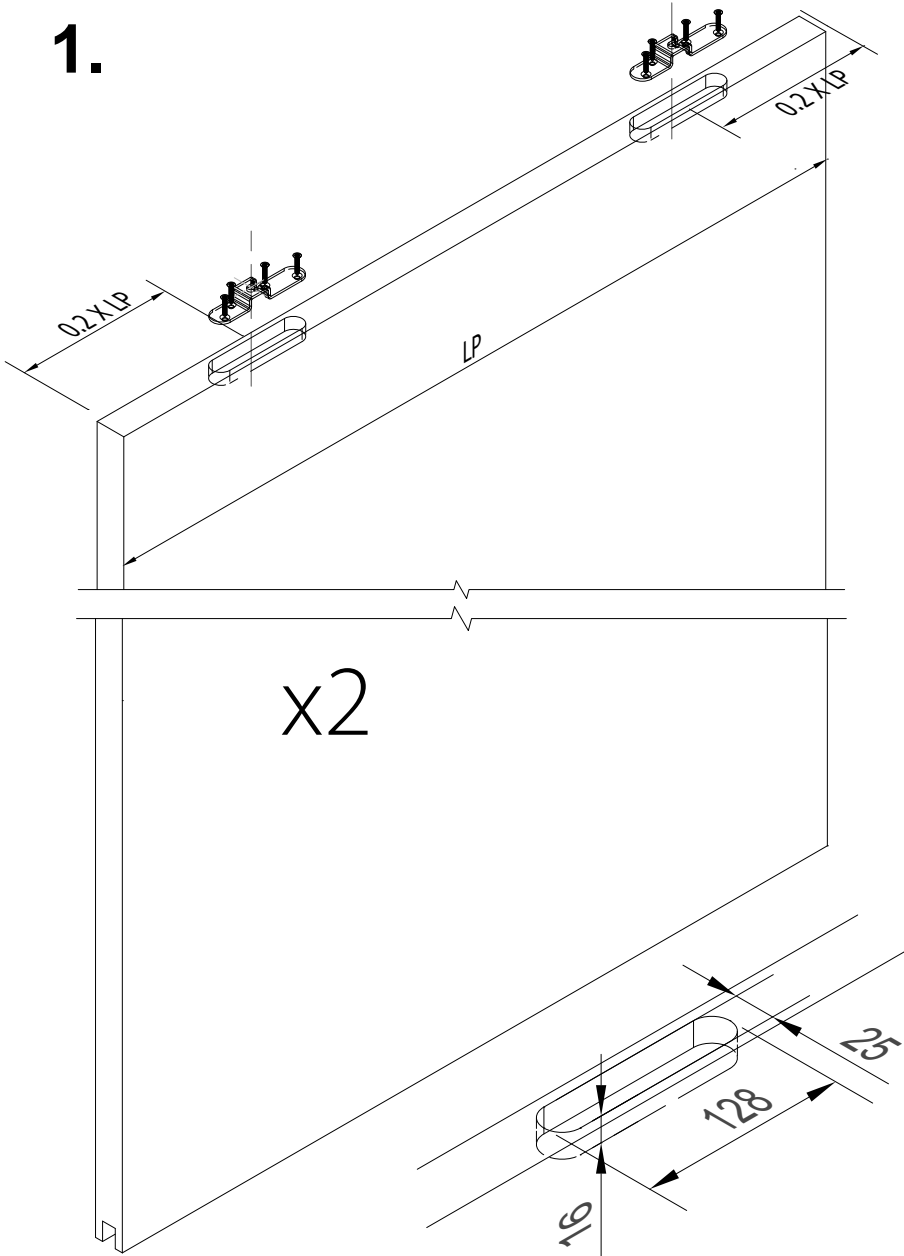

1109 A

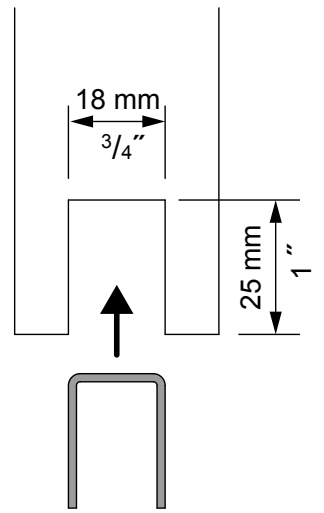

1109

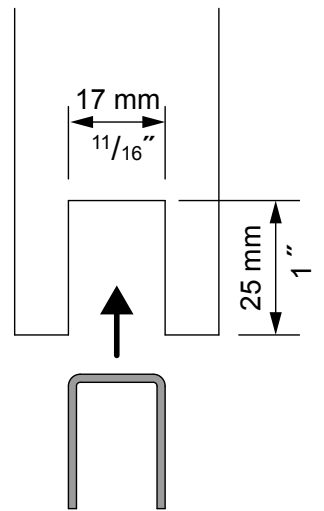

2.

x2

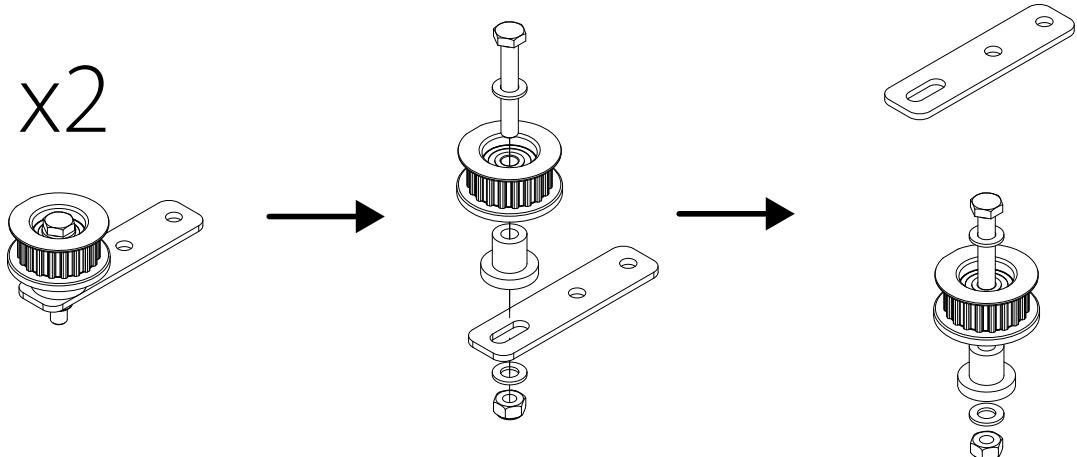

3.

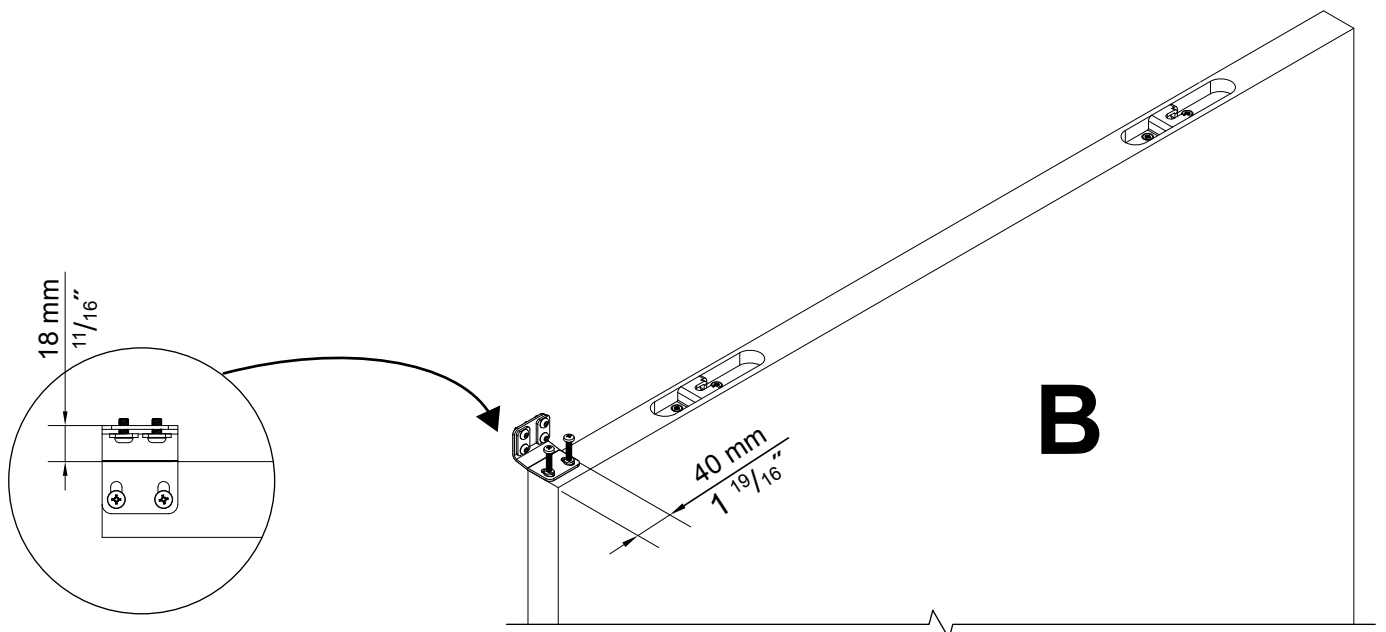
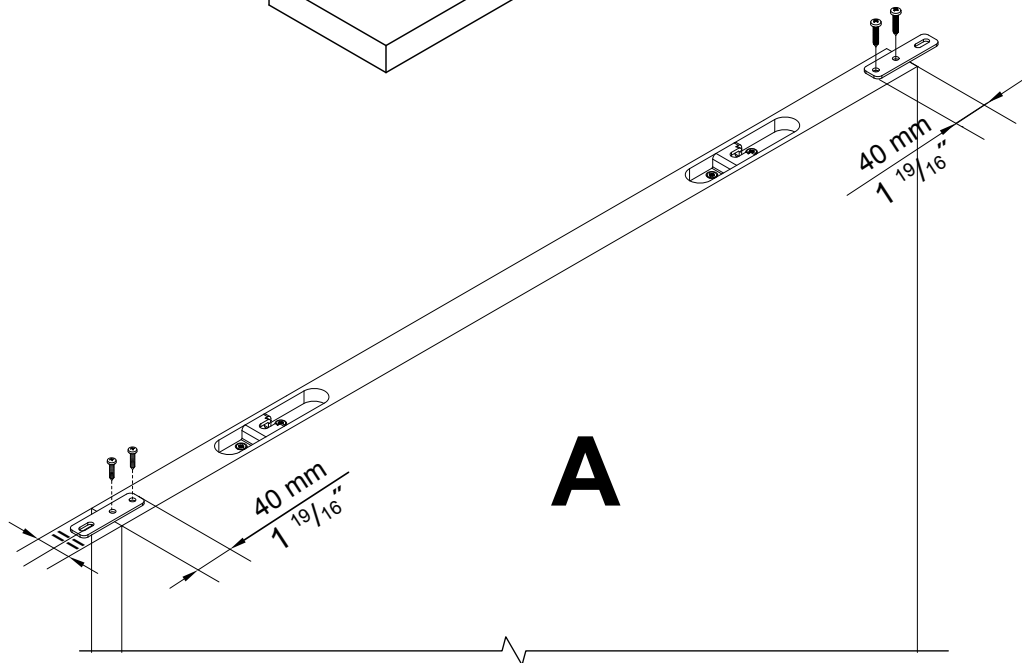
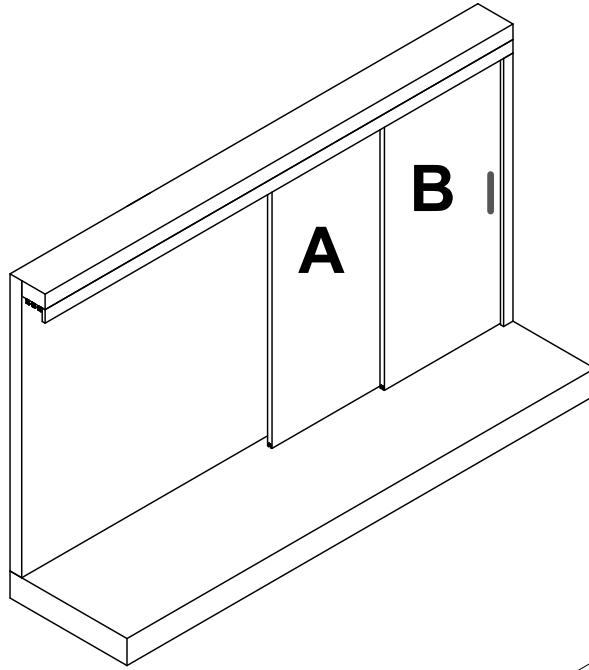

MONTAGE - INSTALLATION - MONTAJE

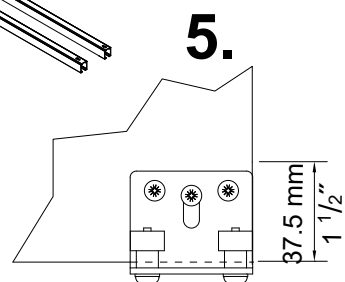
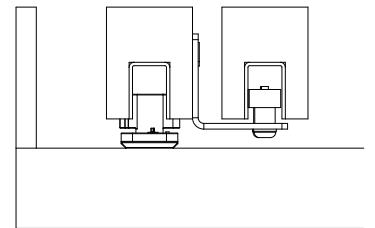
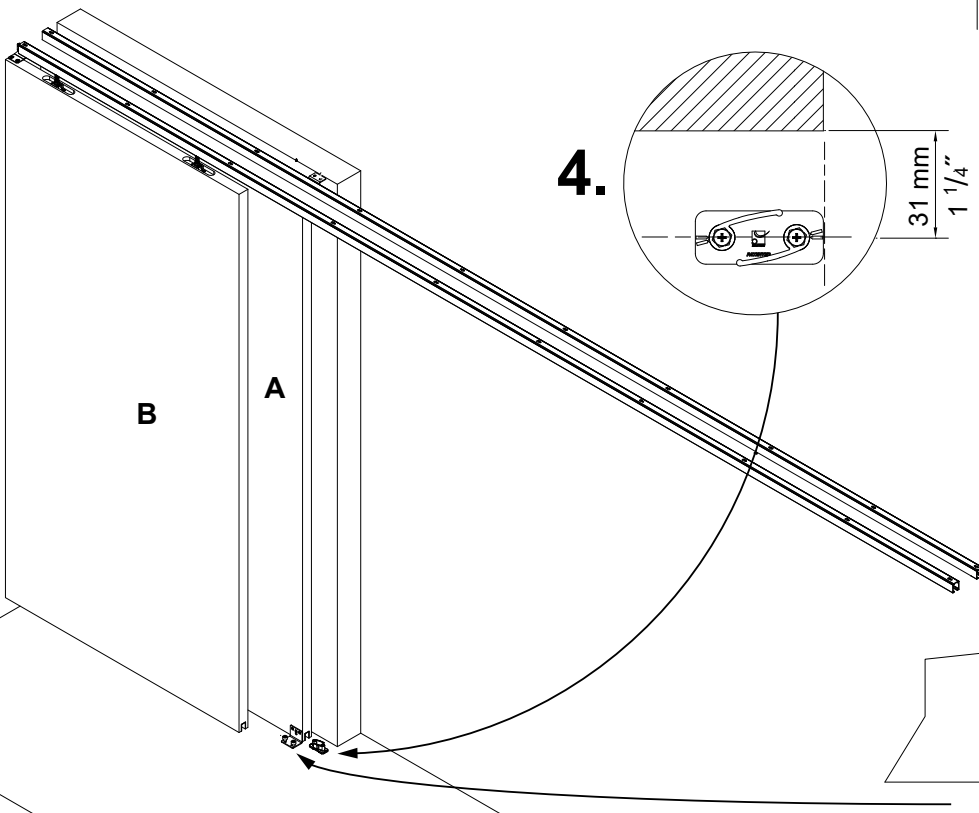
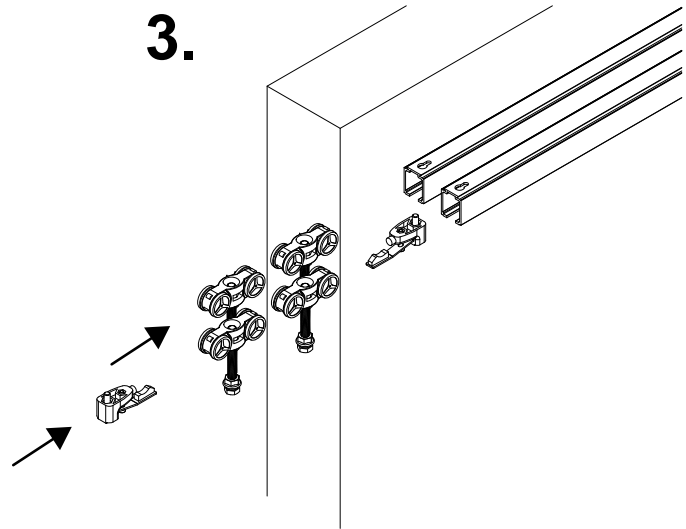
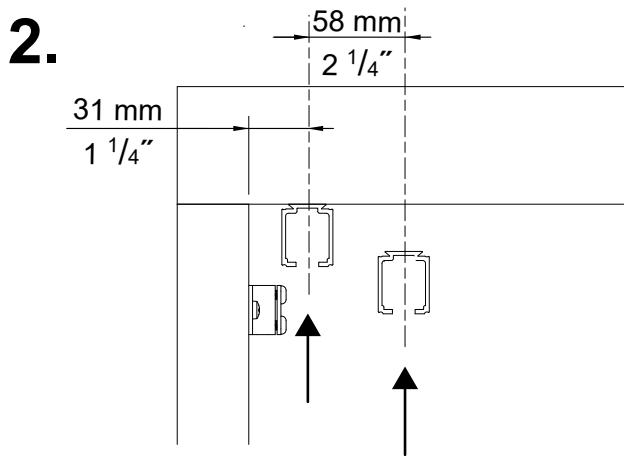
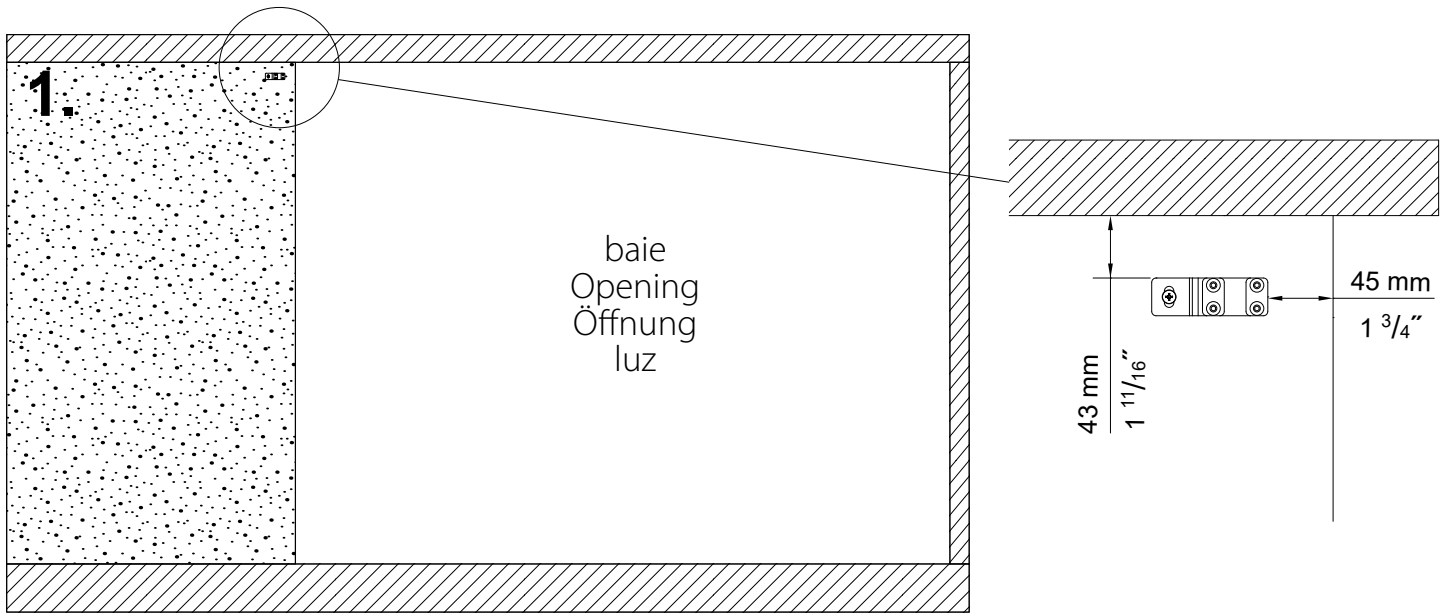

6.

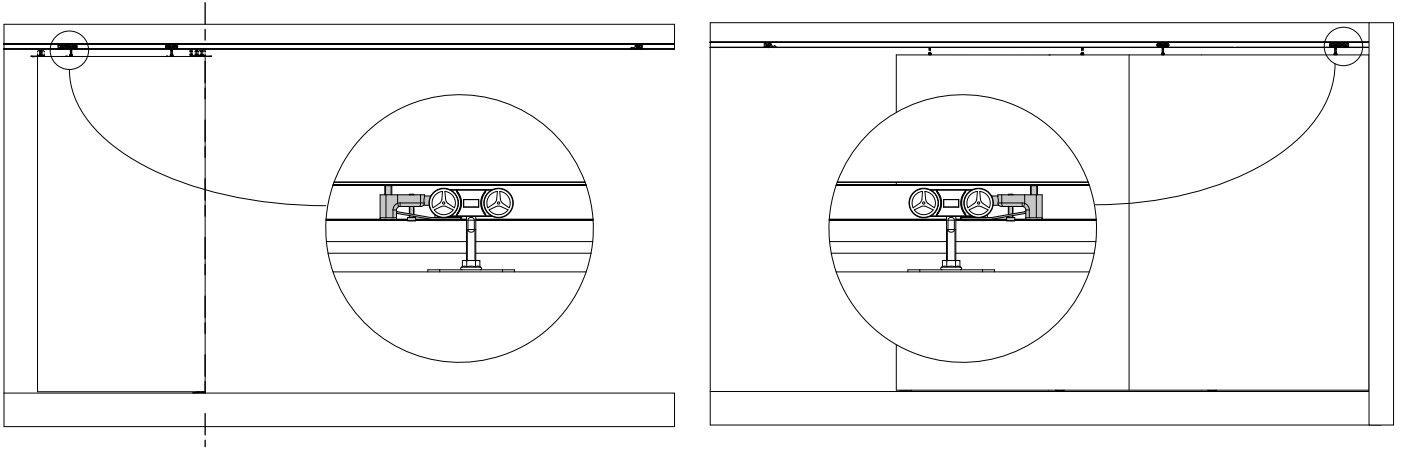

7.

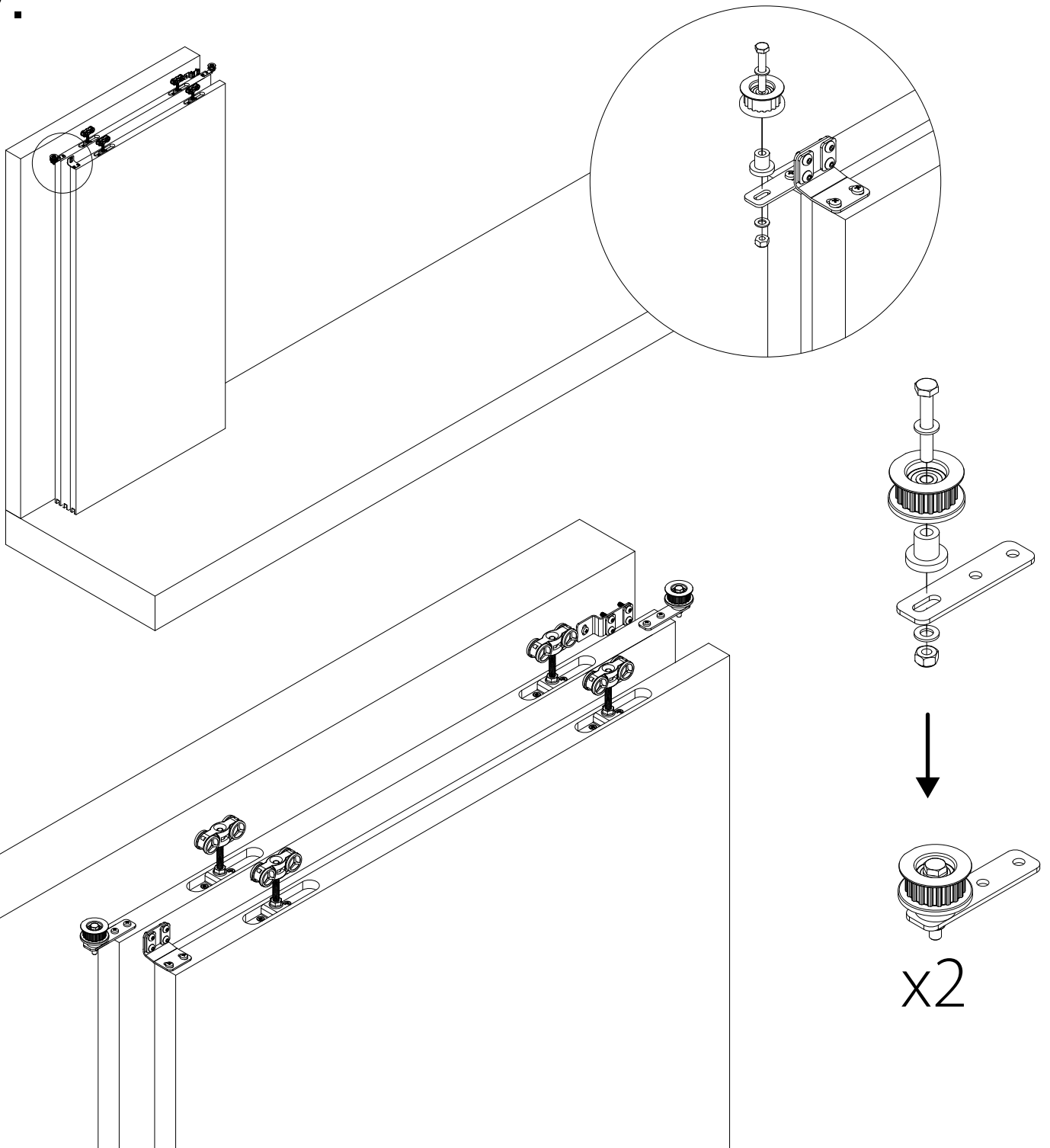

8.

