



NOTICE DE MONTAGE  
MONTAGEANLEITUNG  
INSTRUCTIONS FOR ASSEMBLY  
INSTRUCCIONES DE MONTAJE

# 11525 WIN-FOLD3

MADE IN FRANCE  
SINCE 1920



VOLETS PLIANTS  
FALTSCHIEBELADEN  
FOLDING SLIDING SHUTTERS  
CONTRA VENTANA PLEGABLE

Epaisseur des panneaux Ladendicke Shutter thickness Espesor de las persianas	<b>30 - 34 mm</b>
Dimensions des panneaux Dimensionen der Flügel Dimensions of panels Dimensiones de las persianas	<b>L = 600 mm Max H = 3000 mm Max 0.9 m<sup>2</sup> maxi</b>
Nombre maximum de panneaux Maximale Ladenanzahl Maximum number of panels Numero máximo de las persianas	<b>6 + 6</b>

**SlidSoft**   
match up your projects

calcule instantanément le détail des composants  
(quantitatif, dimensionnement ...)

listet sofort die benötigten Artikel auf

list instantaneously the required items

Calcula al momento el despiece detallado

**[www.mantion.com](http://www.mantion.com)**

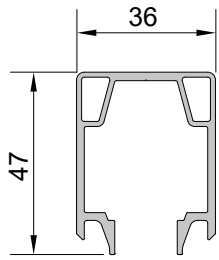

**A**

11525

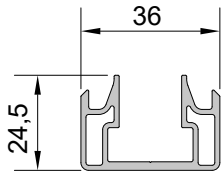

11125

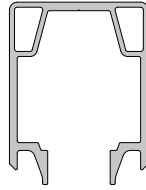
**B**

11525

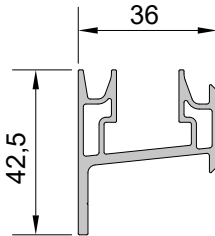

11125E

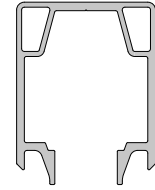
**C**

11525

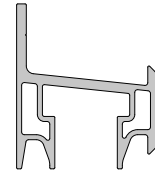

11125E

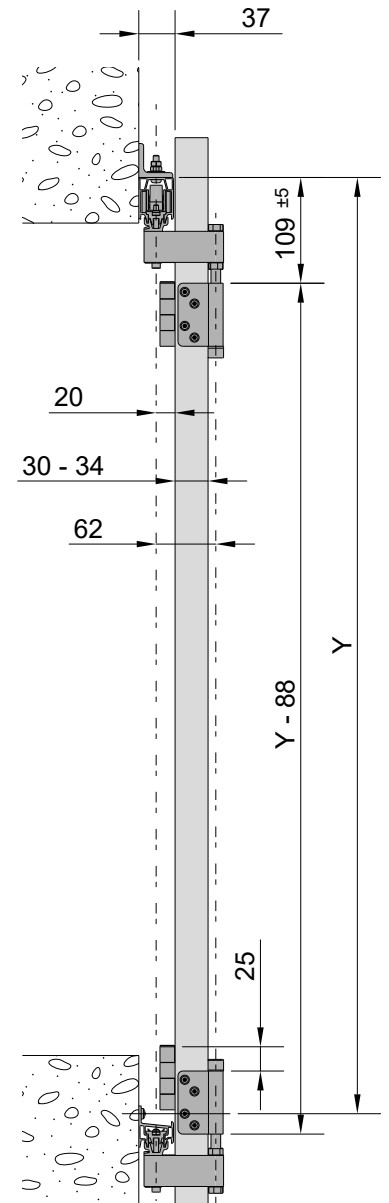
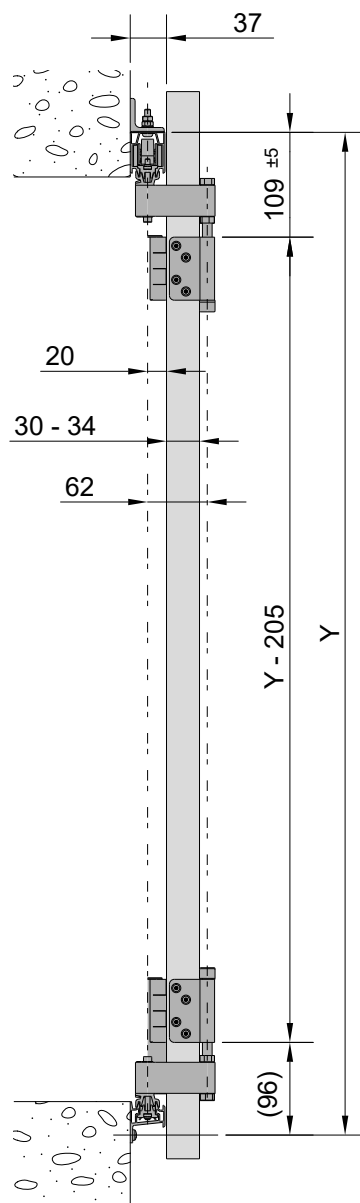
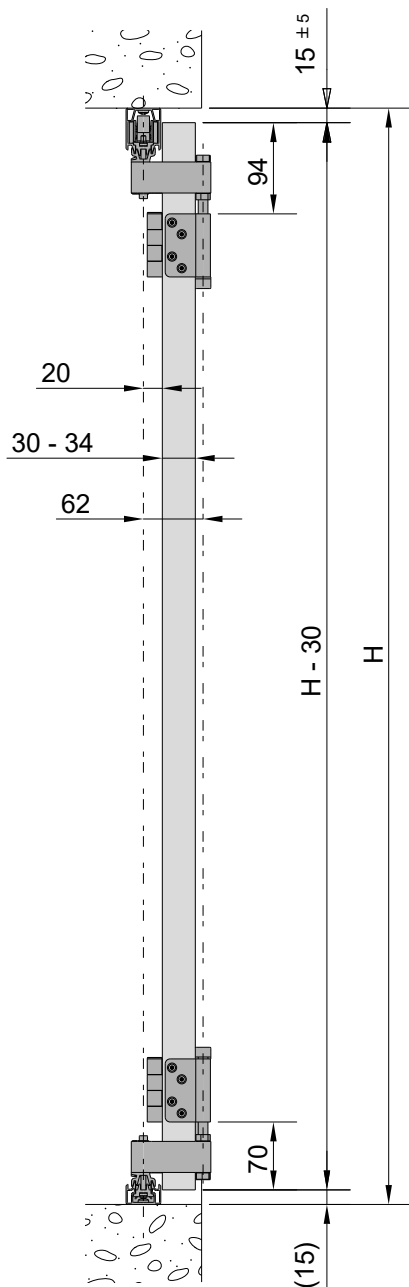

**1 GROUPE DE PANNEAUX - 1 GROUP OF PANELS  
1 GRUPPE VON FLÜGEL**

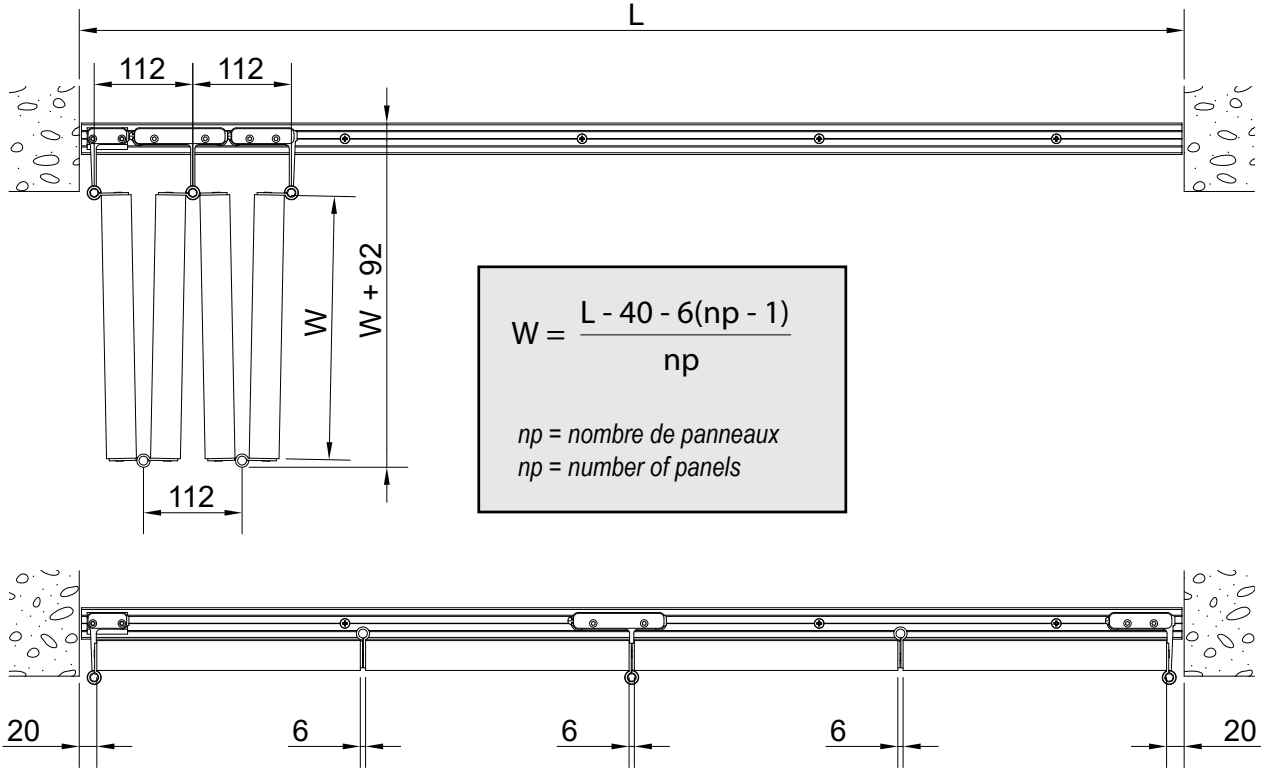

**2 GROUPE DE PANNEAUX - 2 GROUPS OF PANELS  
2 GRUPPEN VON FLÜGEL**

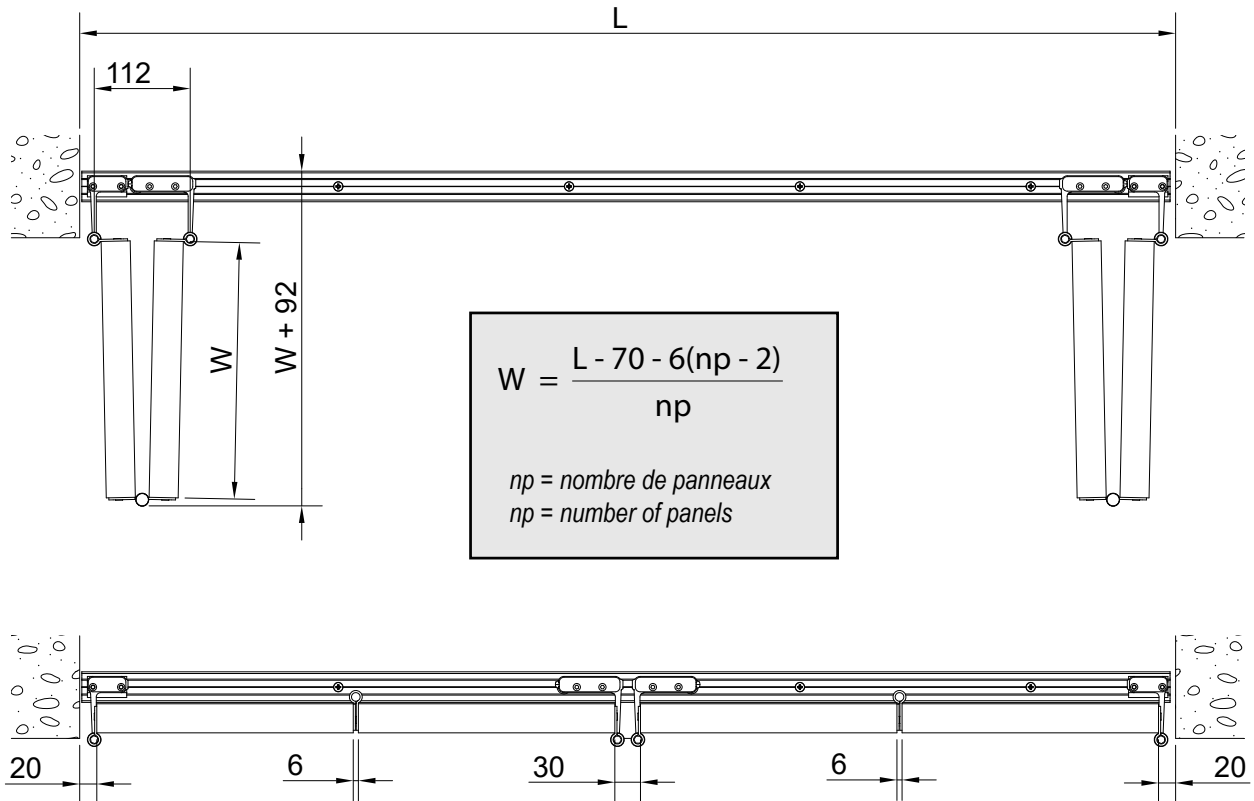

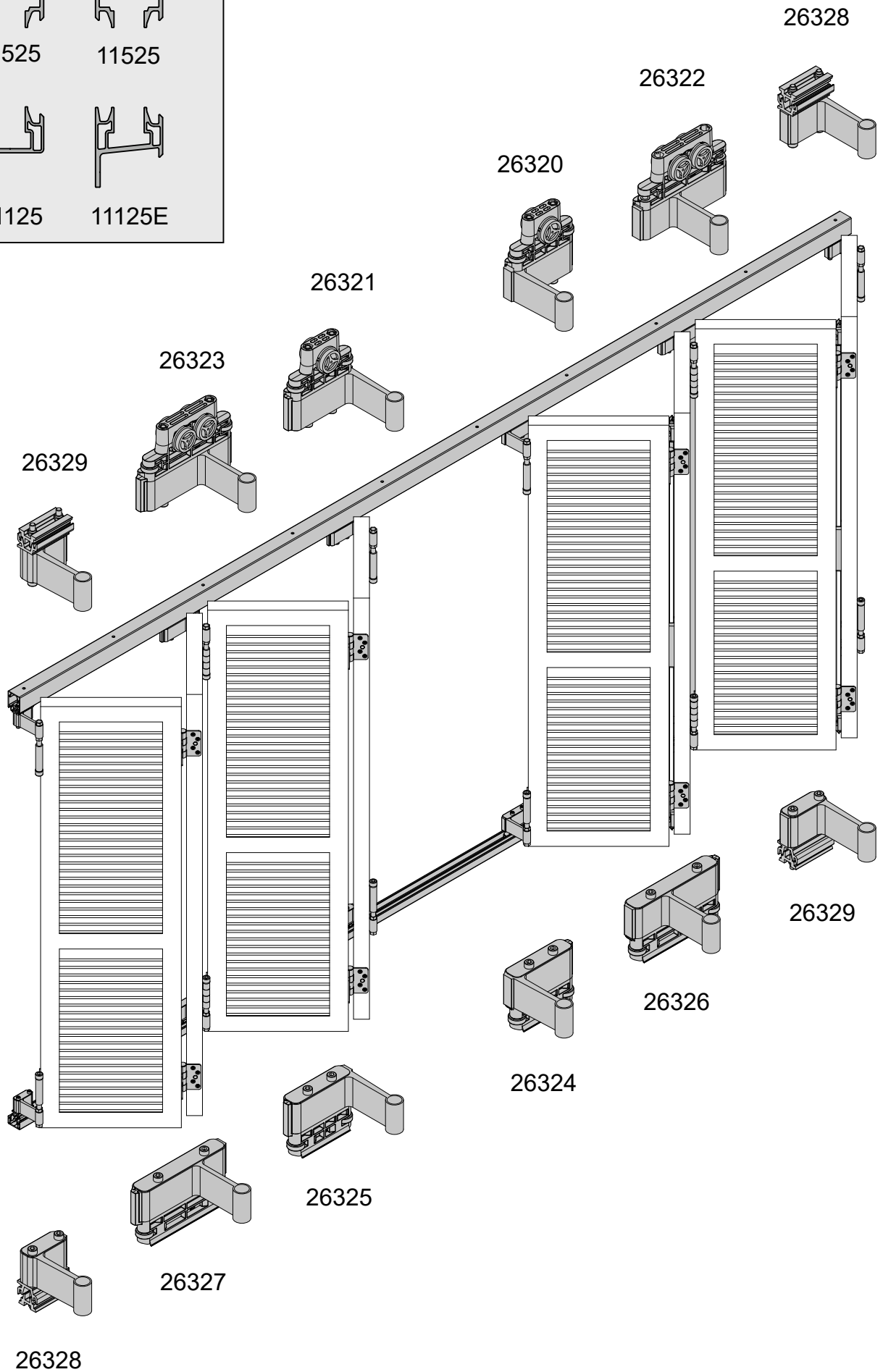
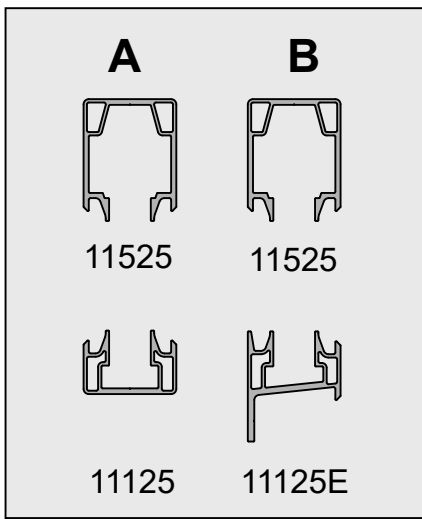

**C**

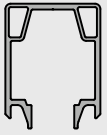

11525

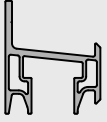

11125E

26328

26322

26320

26321

26323

26329

26328

26327

26325

26324

26326

26329

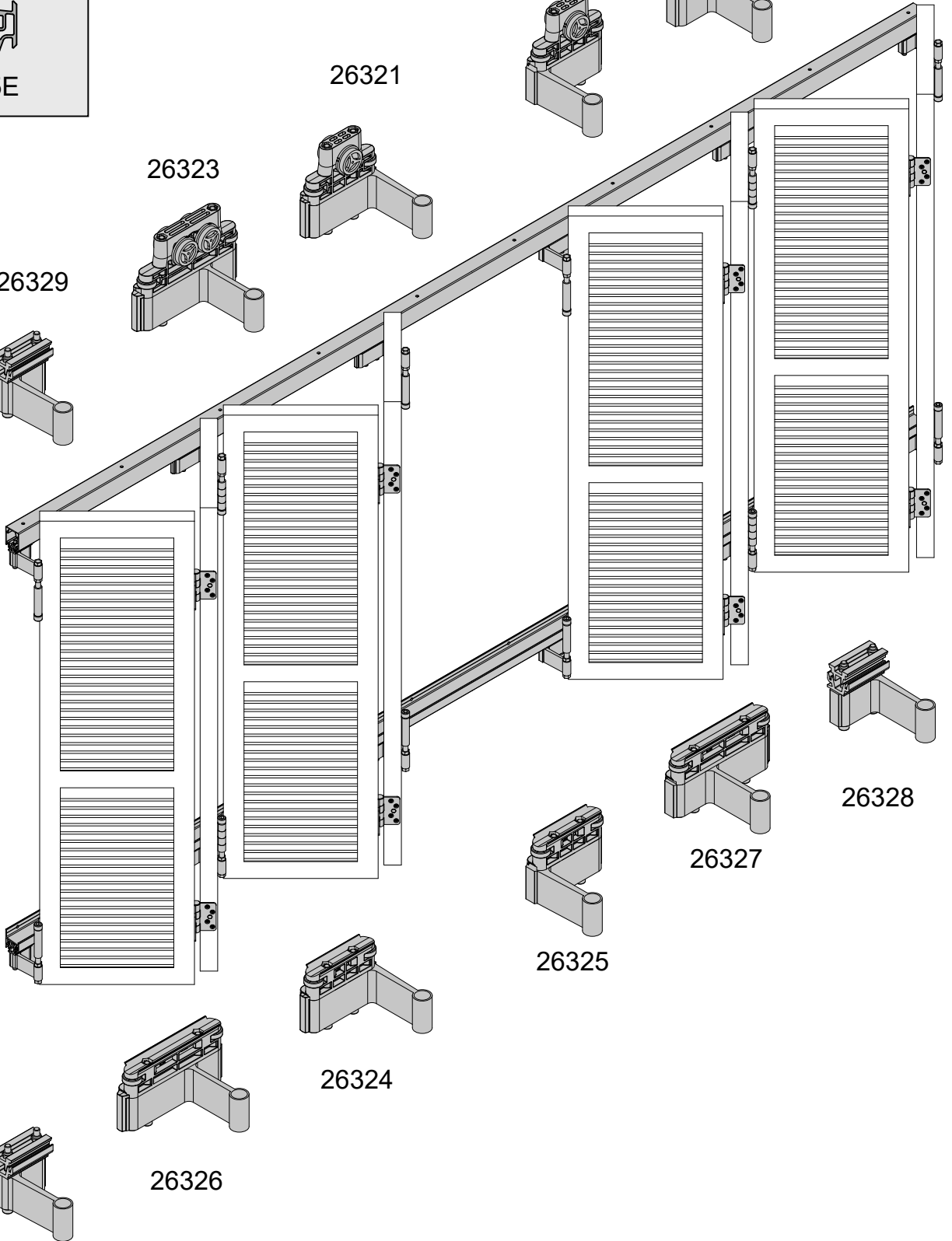

**PRÉPARATION DES PANNEAUX**  
**PREPARIERUNG DER FLÜGEL**  
**PANELS PREPARATION**  
**PREPARACIÓN DE LAS HOJAS**

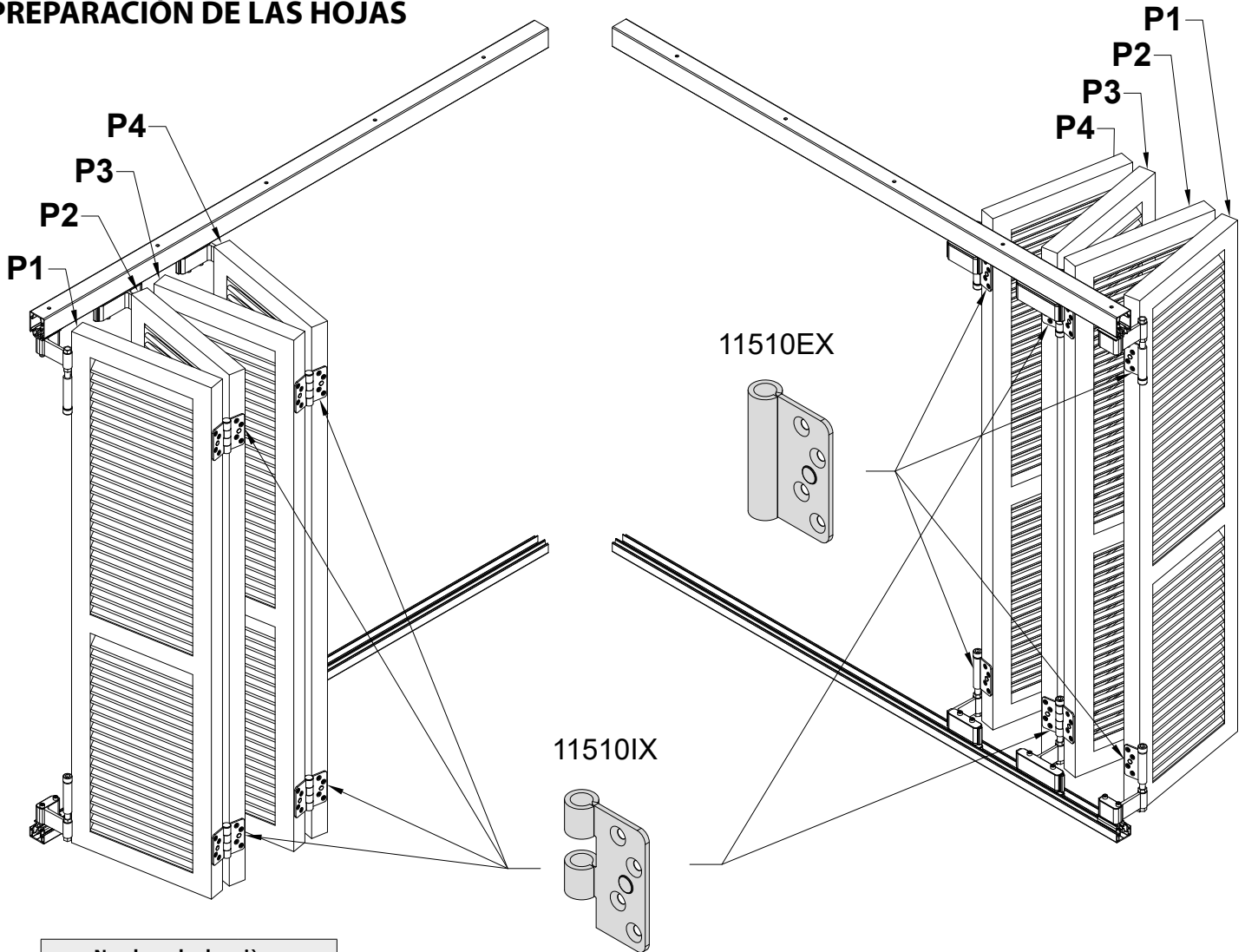

<b>Nombres de charnières</b> <b>Anzahl erforderliche Scharniere</b> <b>Number of hinges</b> <b>Número de bisagras</b>	
Hauteur des panneaux Flügelhöhe panel height altura de hojas	Nombre Stück number piezas
< 1600 mm	2
> 1600 - 3000 mm	3

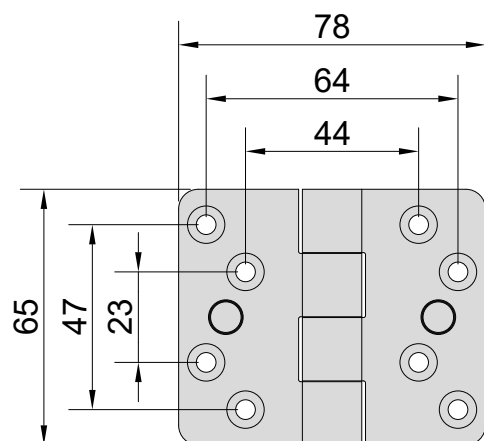
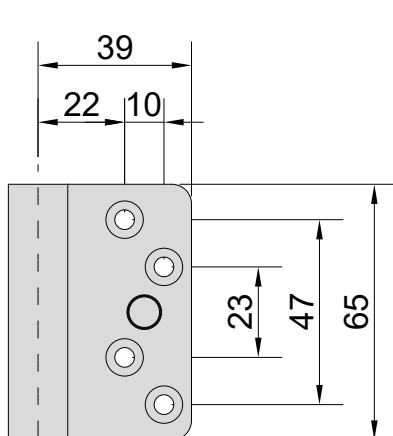
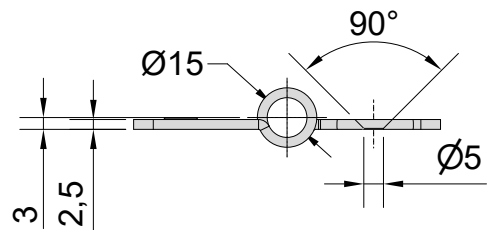

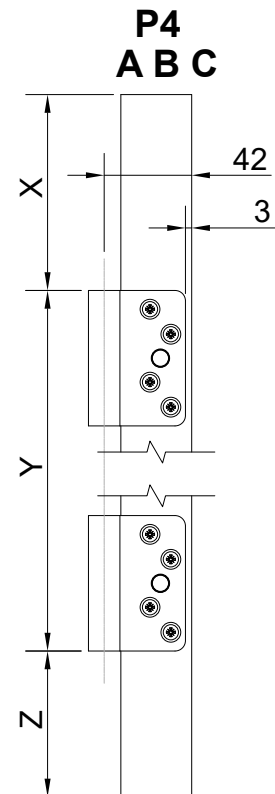
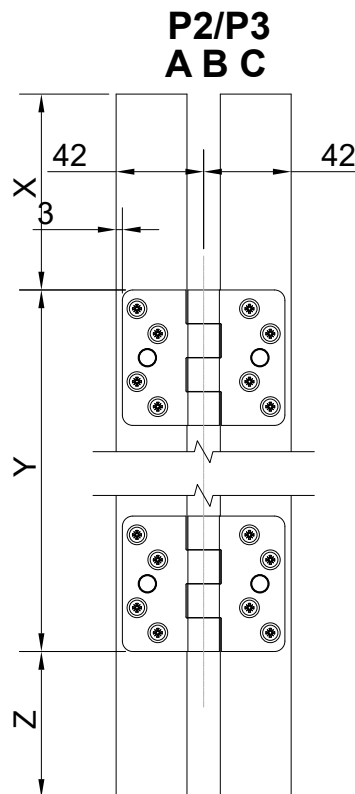
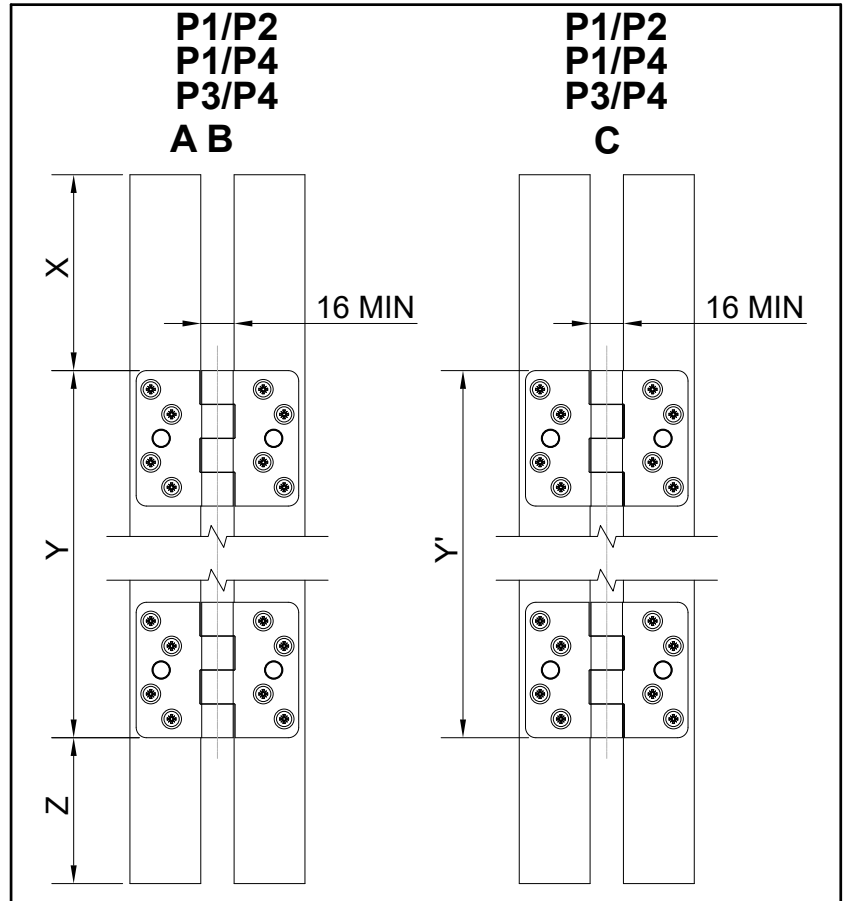
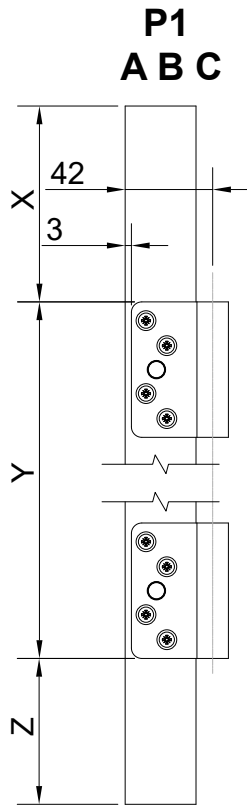
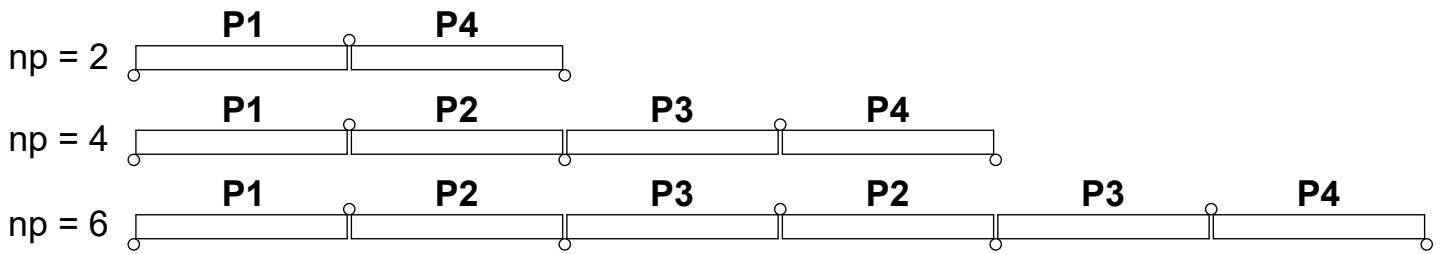

	A	B	C
X	94	-	-
Y	W - 298	D - 205	D - 88
Y'	-	-	Y - 25
Z	74	-	-

# MONTAGE - MONTAGE - MOUNTING - MONTAJE

1.



Vérifier l'équerrage du tableau  
Prüfen Sie zuvor die Winkelhaltigkeit  
Squareness must be checked beforehand  
Compruebe la escuadría del hueco

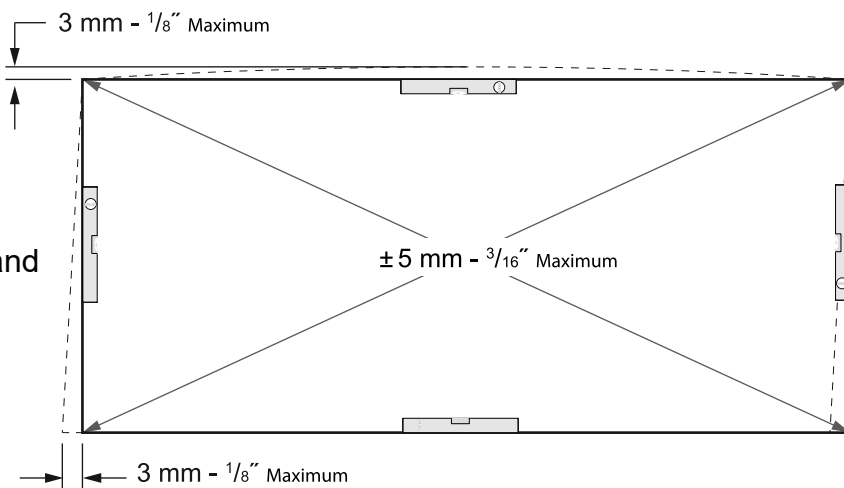

## 2. Mise en place rail et profil de guidage

2.a

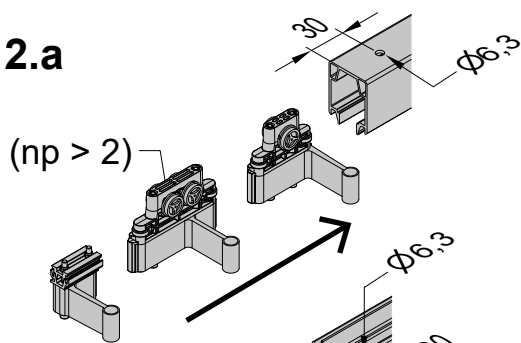

(np > 2)

2.b

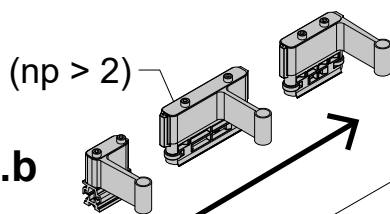

(np > 2)

2.c

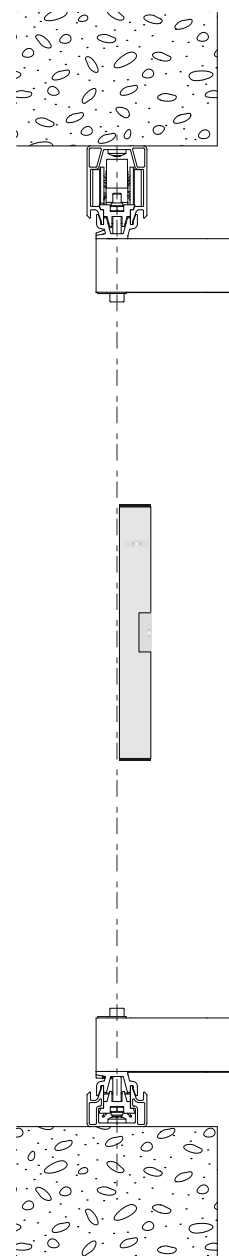
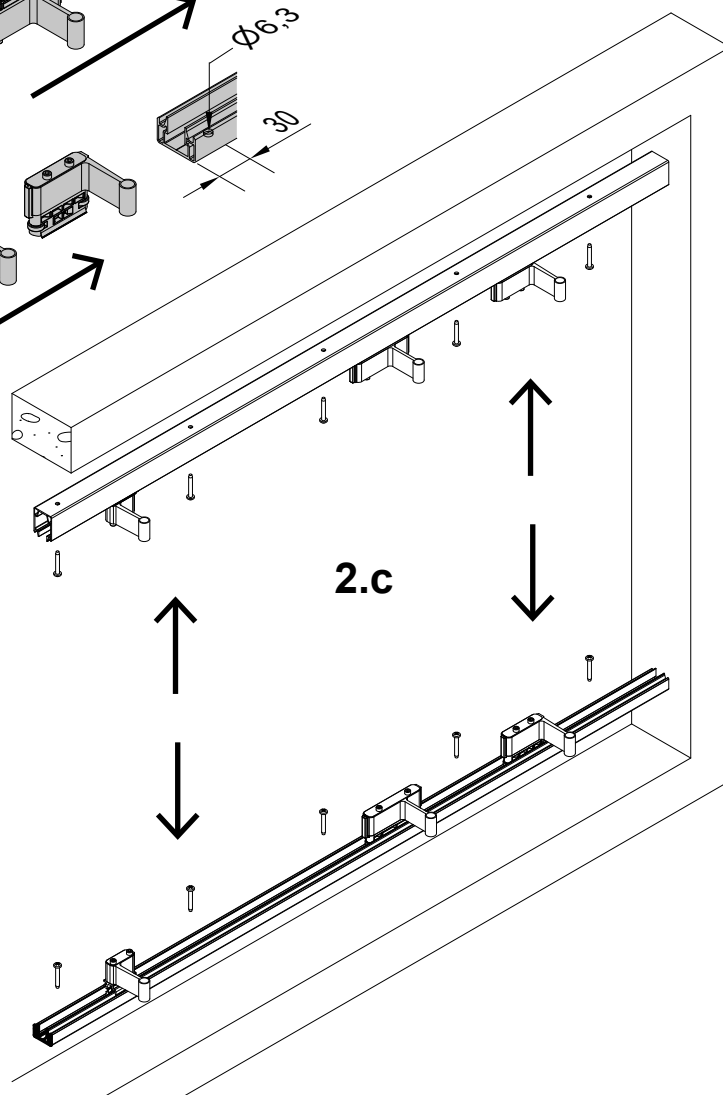

### 3. Montage P1

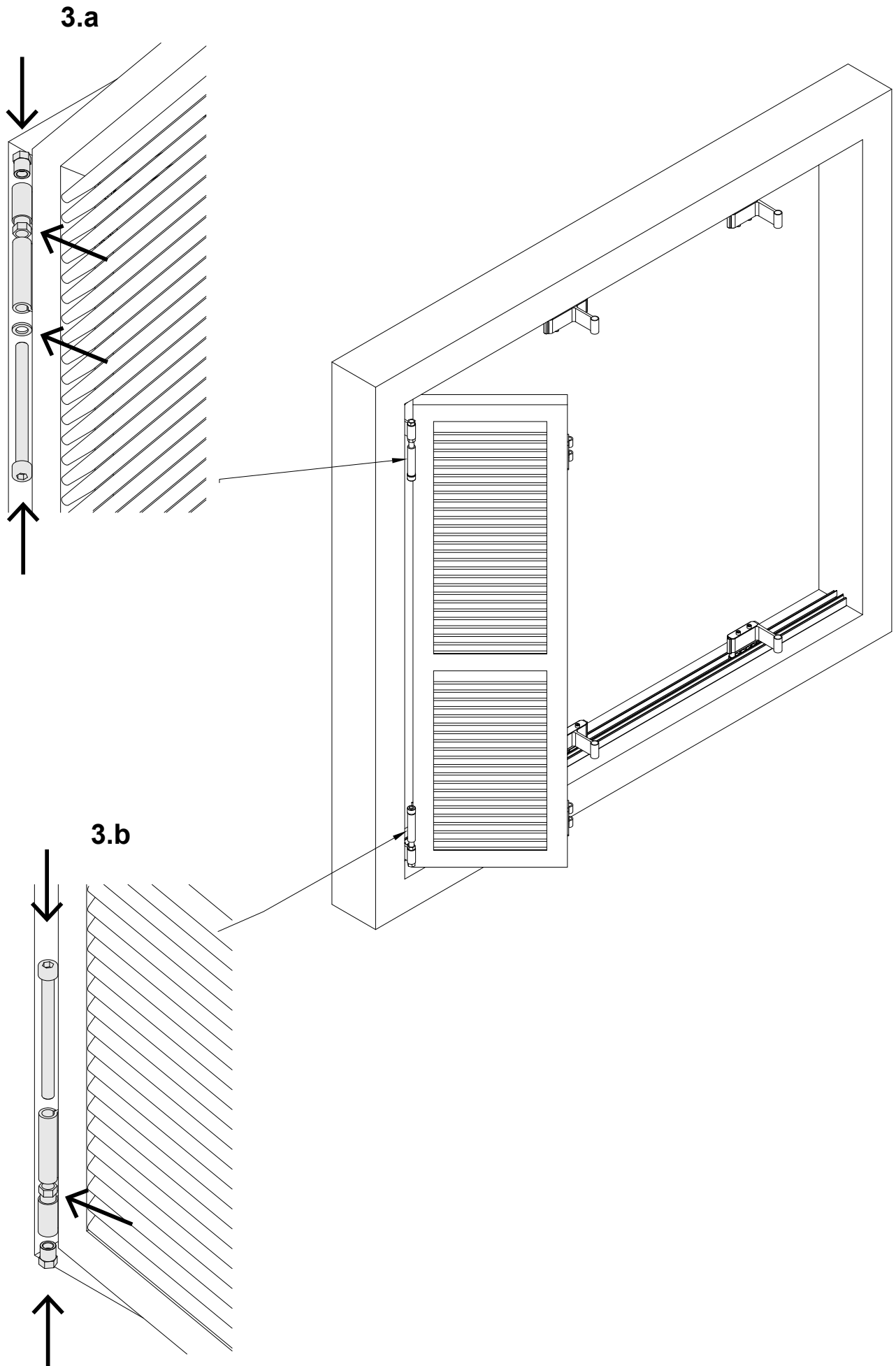

Clé BTR 4

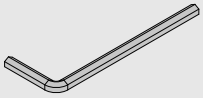

3.c

3.d

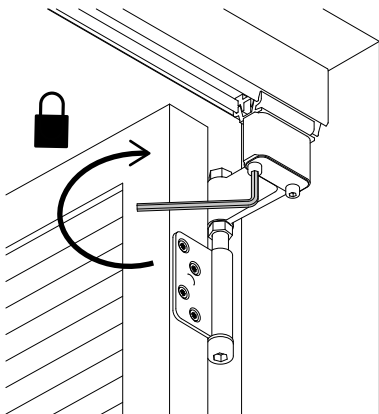

20

3.e

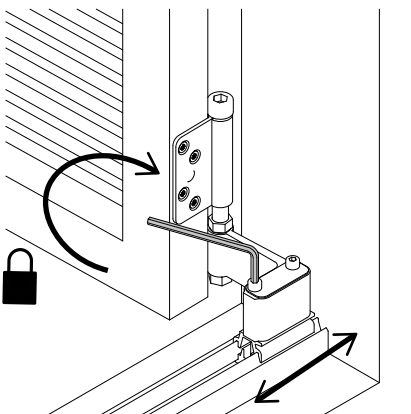

## 4. Réglage vertical et serrage

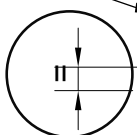
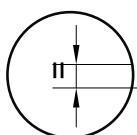
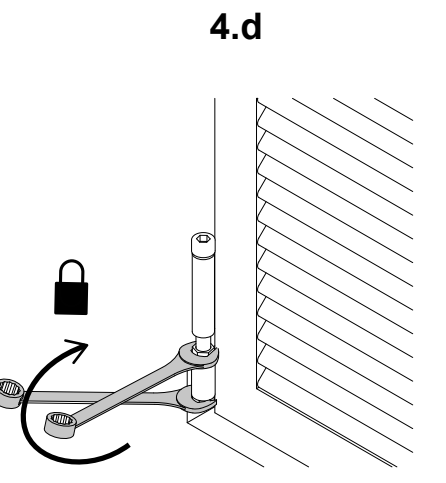
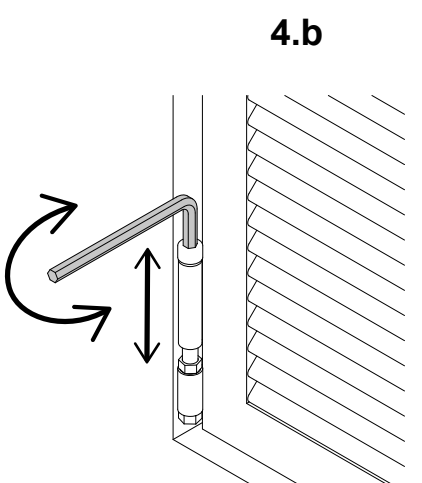
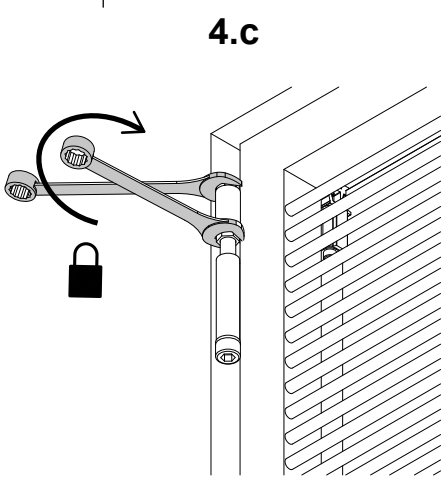
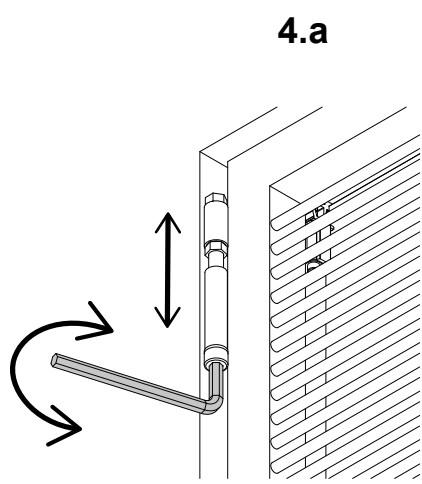
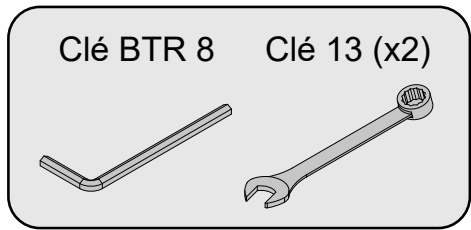

2 MIN

## 5. Montage P2

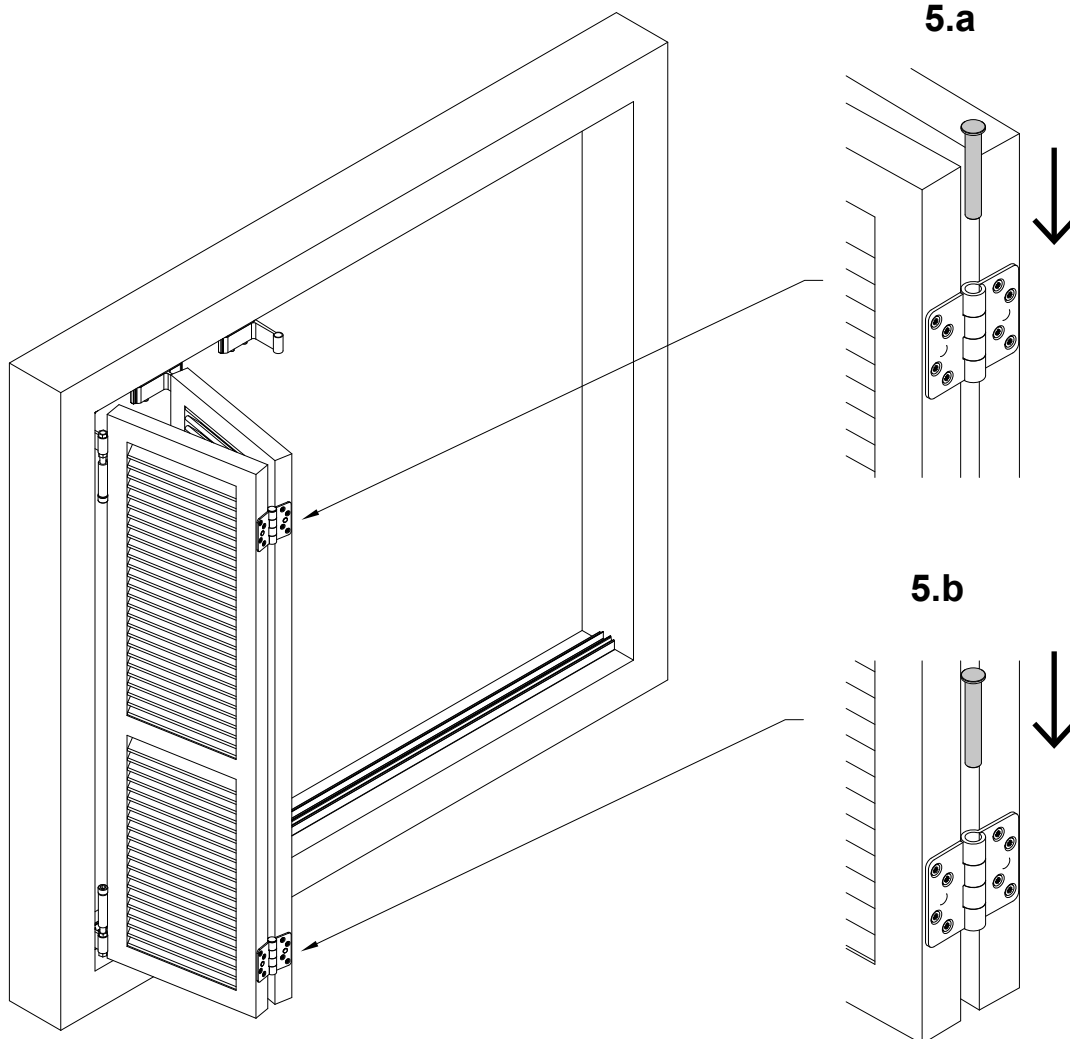
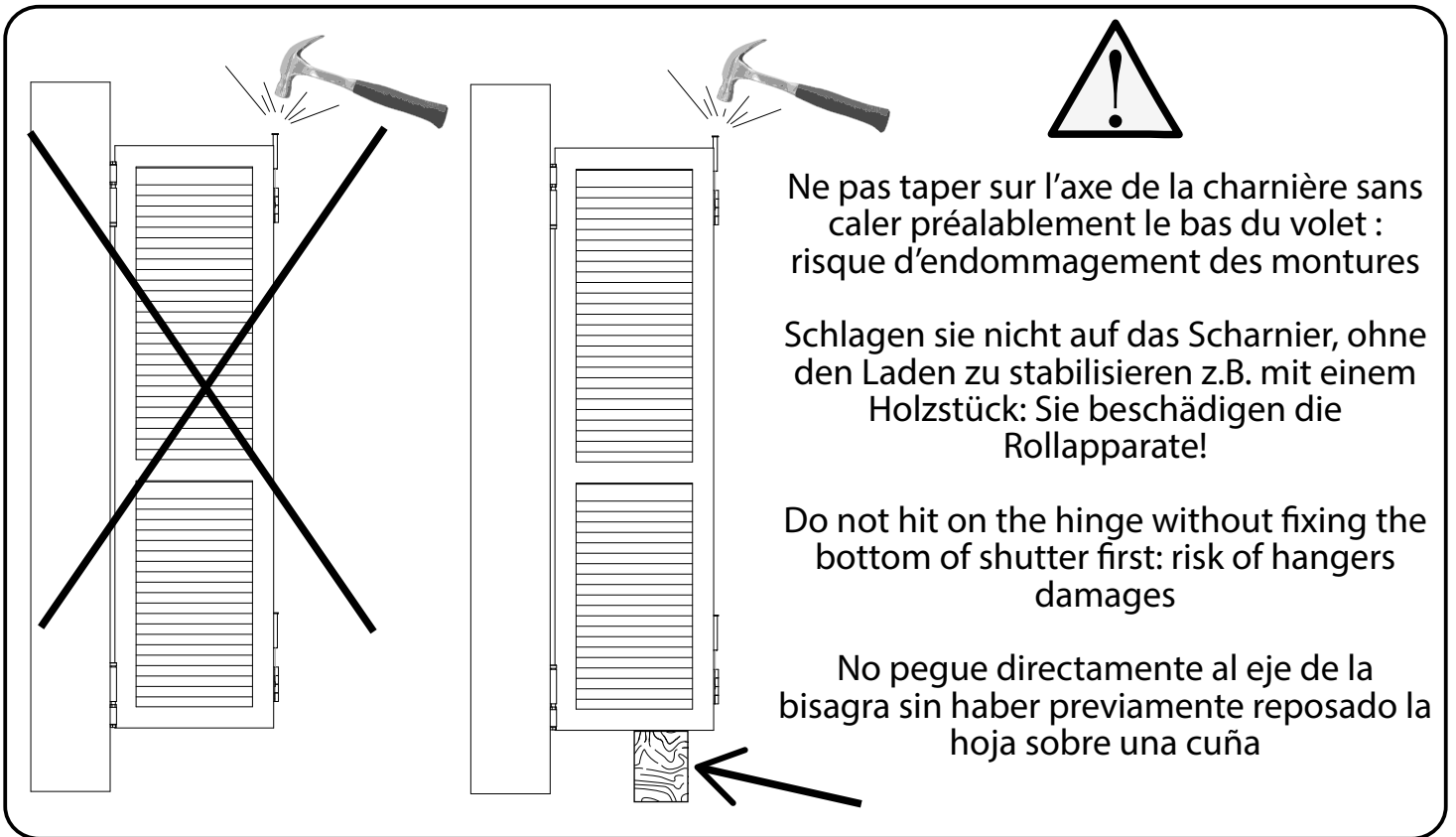

## 6. Montage P3 (np > 2 seulement)

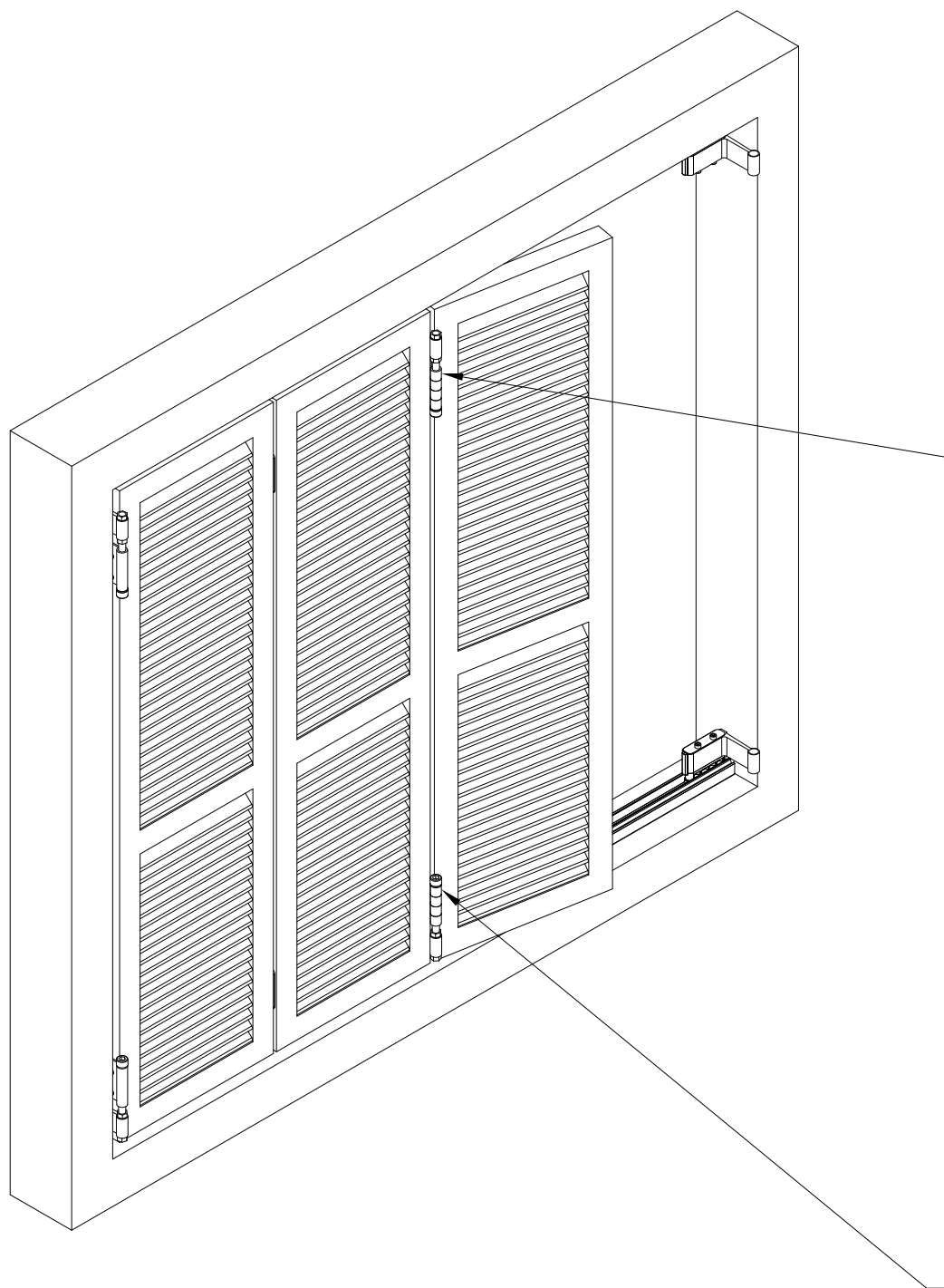

6.a

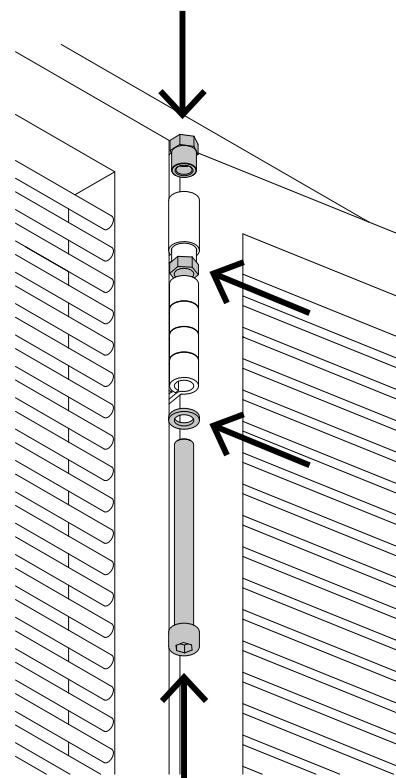

6.b

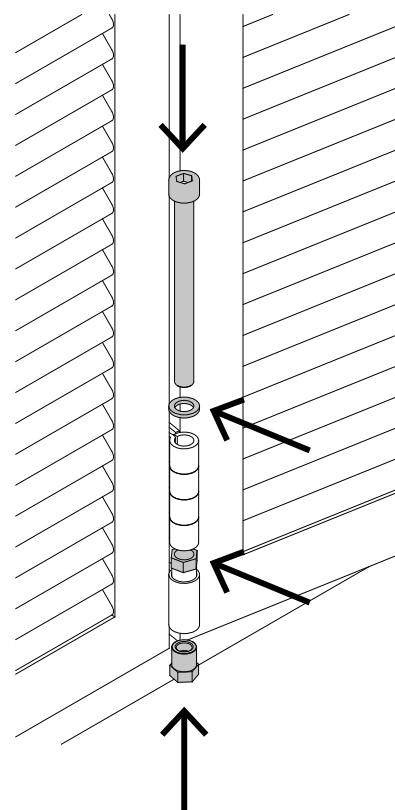

## 7. Réglage vertical et serrage

Clé BTR 8

Clé 13 (x2)

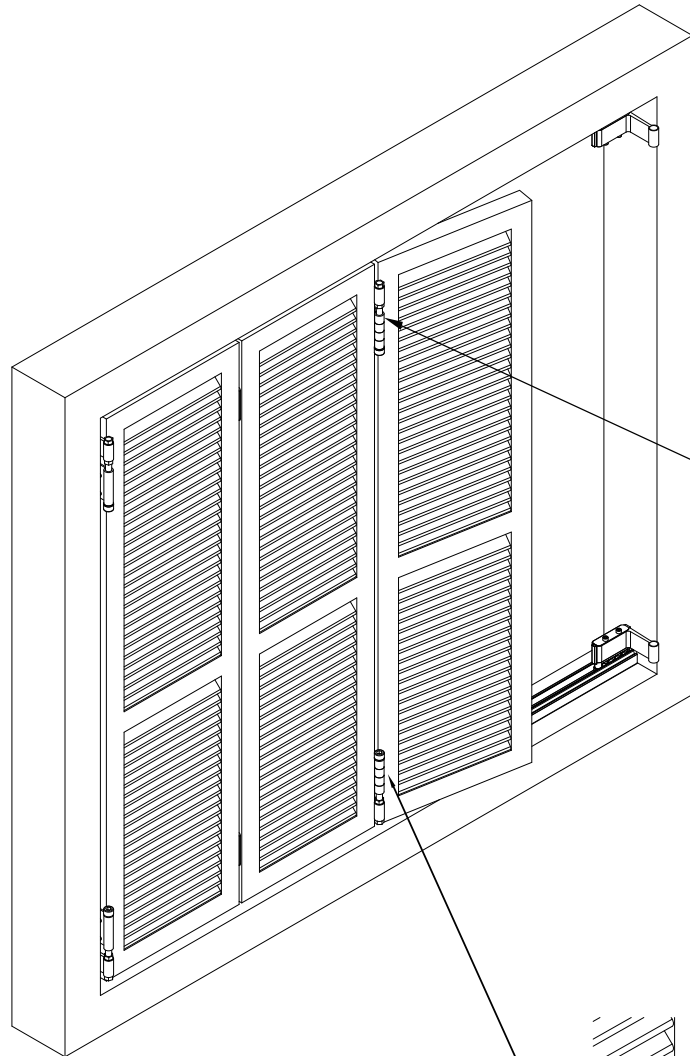
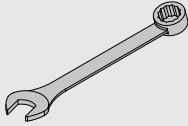
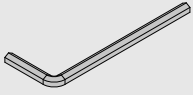

7.a

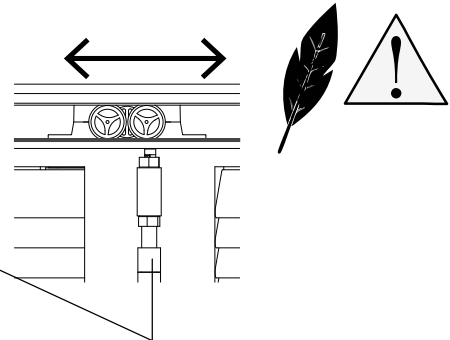
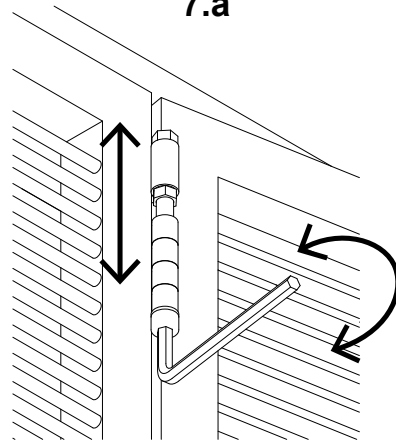

7.b

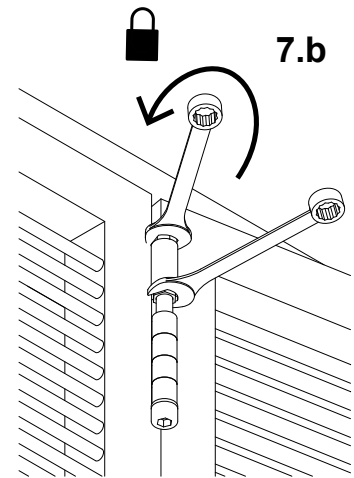

7.c

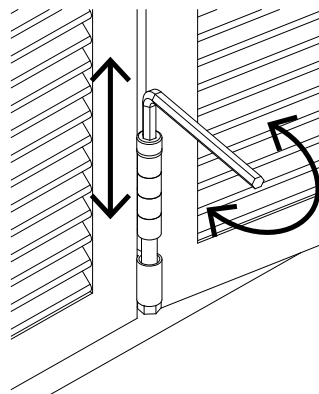

7.d

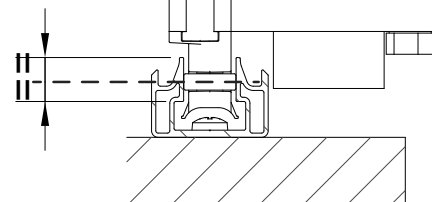
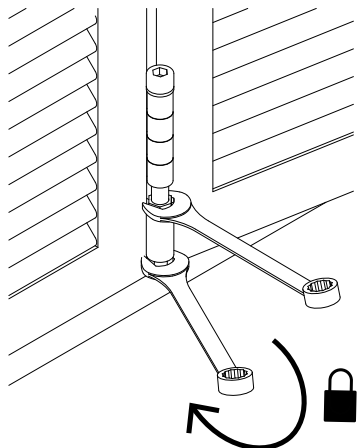

# 8. Montage P4

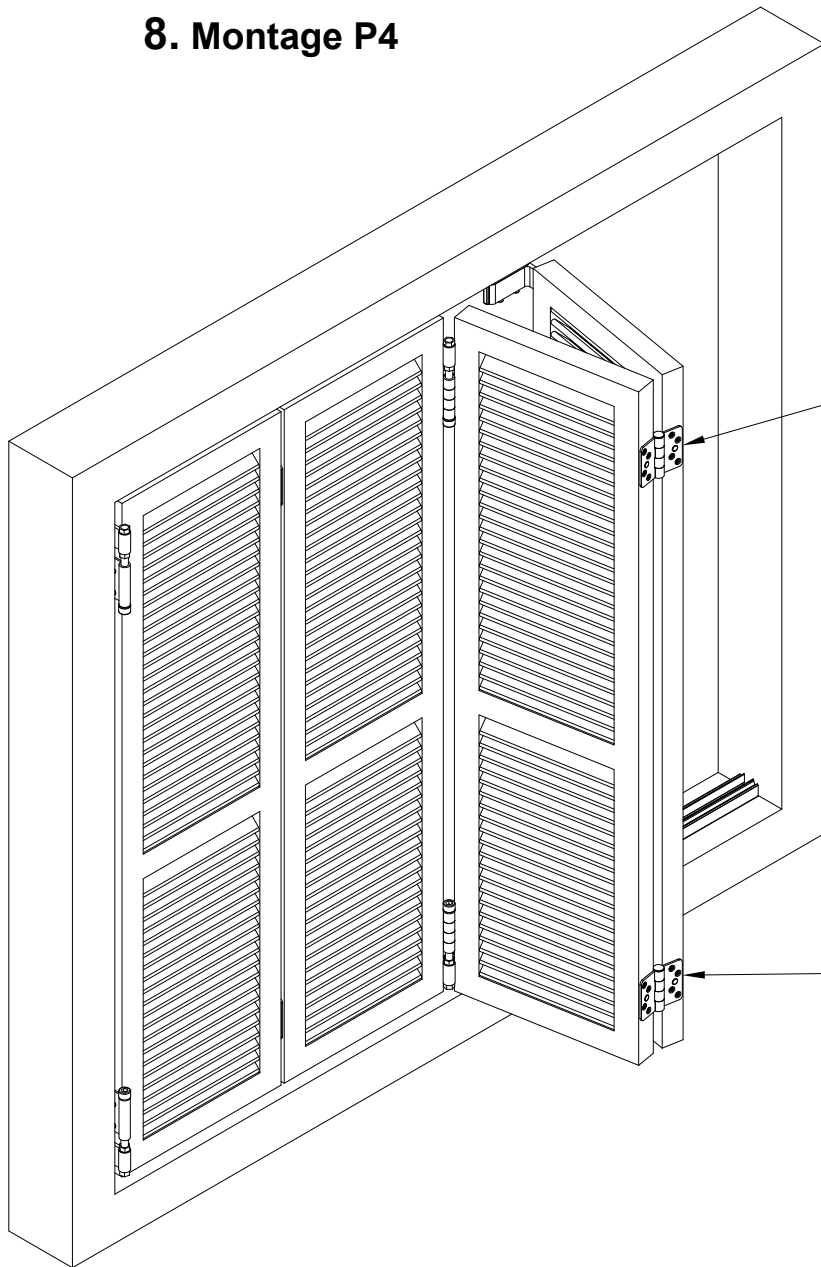

8.a

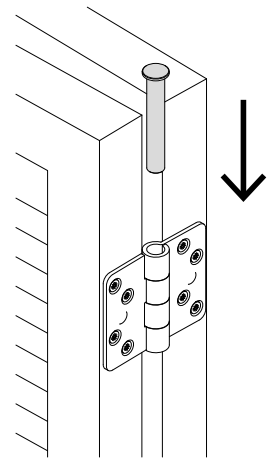

8.b

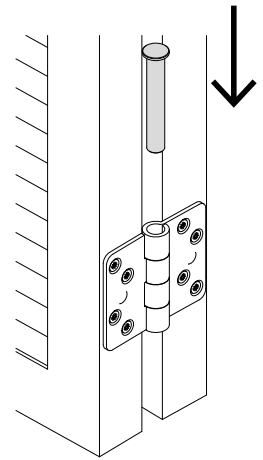

8.d

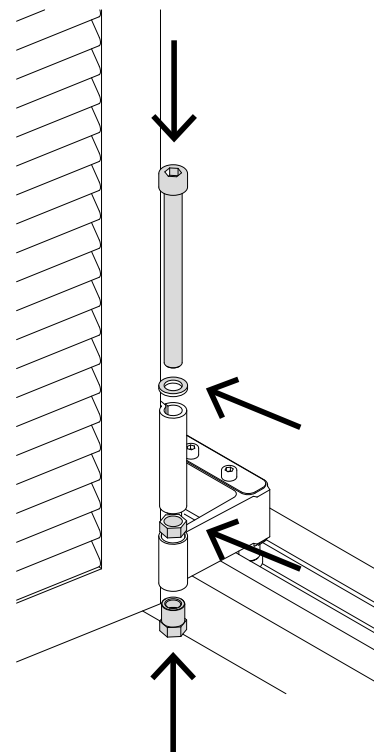
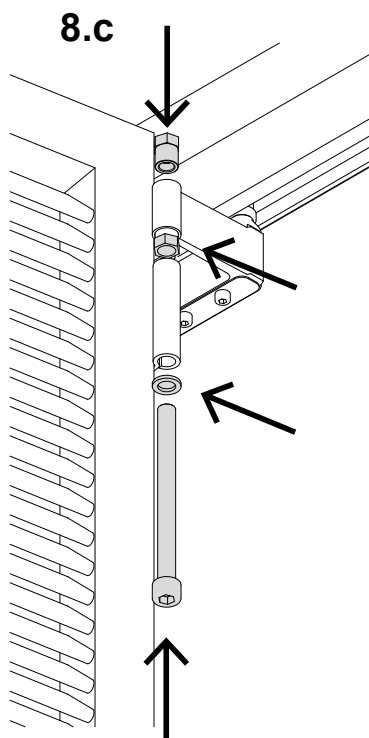

## 9. Réglage vertical et serrage

Clé BTR 8

Clé 13 (x2)

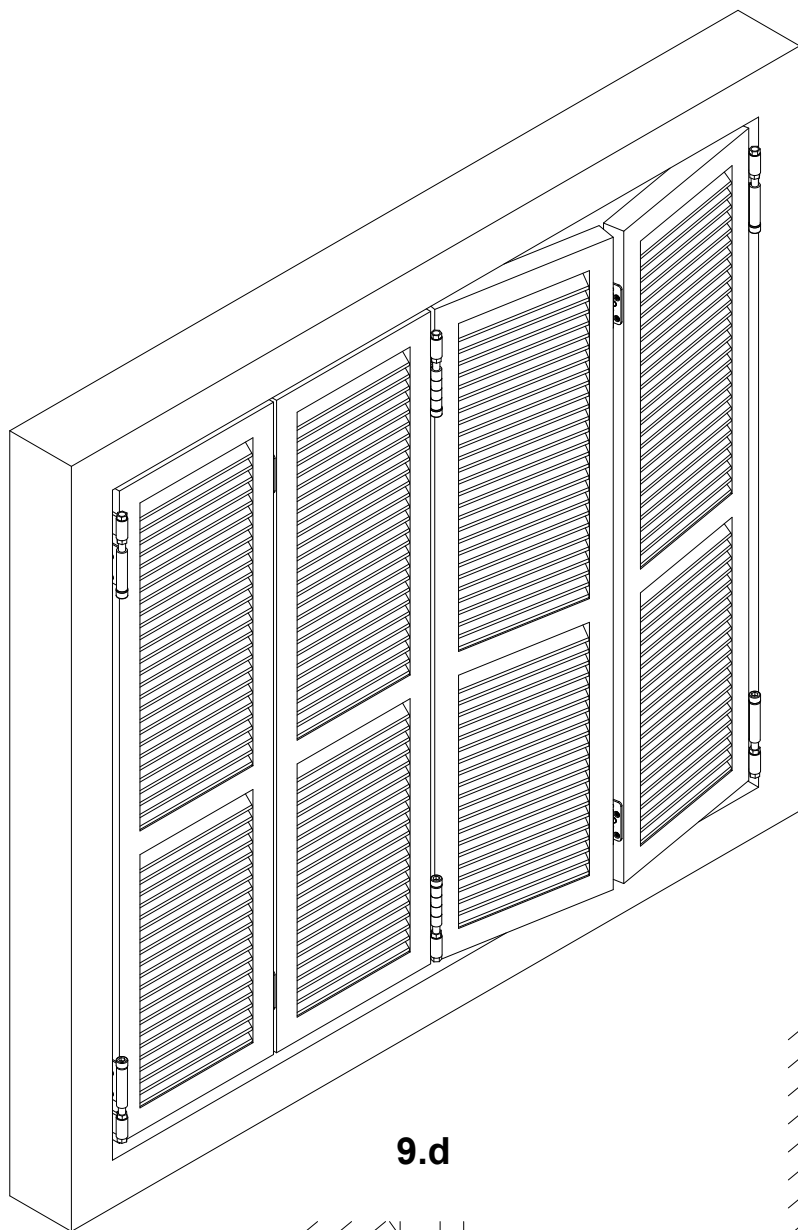
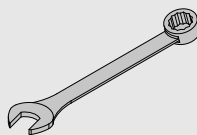
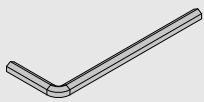

9.a

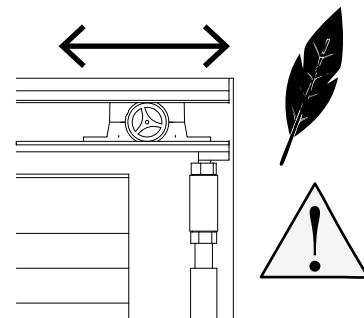
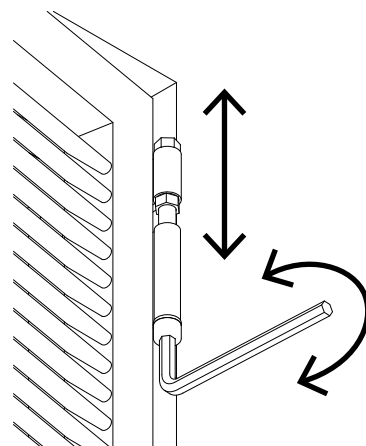

9.b

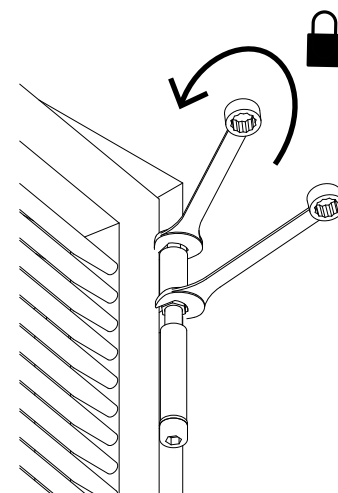

9.c

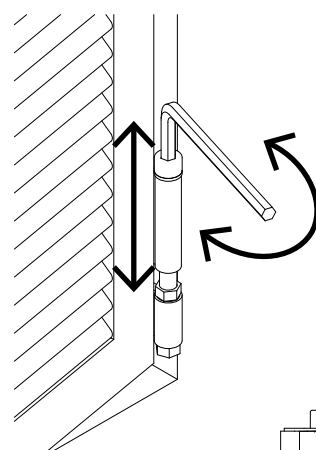

9.d

