



INSTRUCTION DE MONTAGE
MONTAGEANLEITUNG
INSTRUCTIONS FOR ASSEMBLY
INSTRUCCIONES DE MONTAJE

SAF-TELESCOPIC

NM_SAFTL_008

Poids maximal des panneaux Maximales Gewicht Maximum weight Peso máximo	80 KG 176 lbs.
Epaisseur des panneaux Ladendicke Shutter thickness Espesor de las contraventanas	38-40 mm 1 1/2" - 1 9/16"
Largeur maximale des panneaux Maximale Flügelbreite Maximum panel width Ancho máximo de panel	700-1500 mm 2ft 3 9/16" - 4ft 11 1/16"

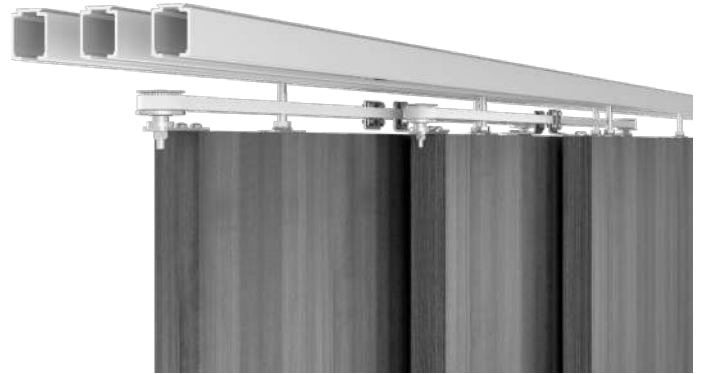

COMPOSITION - ZUSAMMENSETZUNG - COMPOSICIÓN

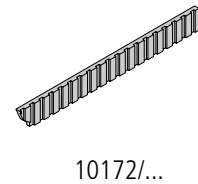
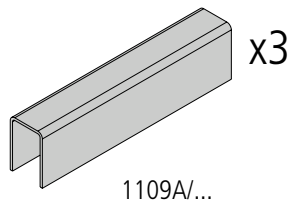
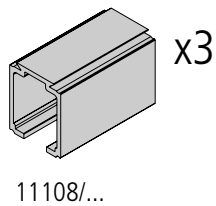

SAF81-TL3

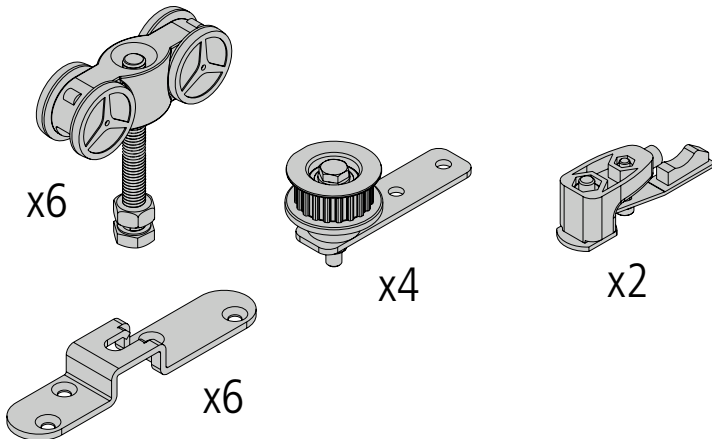

1102TL3

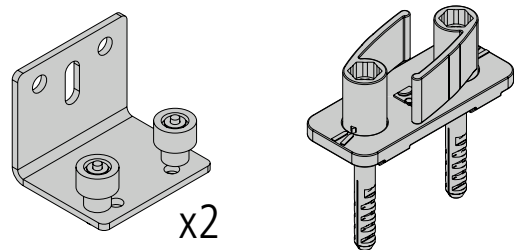

10190S13

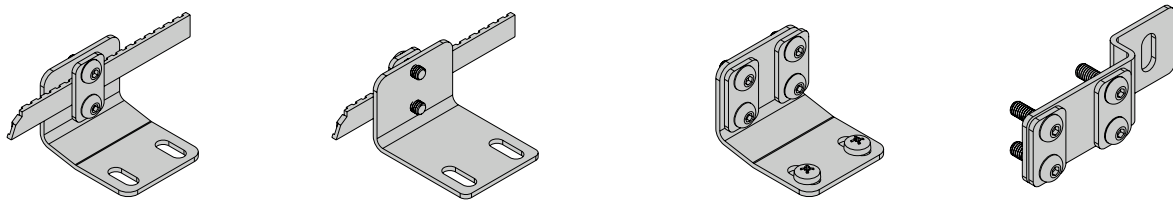

CONDITIONS DE POSE / MONTAGEBEDINGUNGEN / INSTALLATION REQUIREMENTS / CONDICIONES DE COLOCACION:

- Produit destiné à une utilisation en intérieur / Dieses Produkt ist nur für Innenanwendung geeignet / For indoor use only / Producto para utilización en interior
- Ne pas installer dans des endroits humides / Nicht in feuchten Atmosphären verwenden / Do not install in humid places / No instalar en lugares húmedos
- Le montage doit être effectué par des monteurs qualifiés / Die Montage muss von qualifizierten Handwerkern geführt werden / Installation must be performed by skilled personnel / el montaje tiene que hacerse por instaladores cualificados

DIMENSIONS / MASSE / SIZING / DIMENSIONES (mm):

- Epaisseur panneau / Paneelstärke / Panel thickness / Grueso del panel: **38 -40 mm**
- Poids panneau / Paneelgewicht / Panel weight / Peso panel: **80 Kg MAX**

38 mm - 1 1/2"

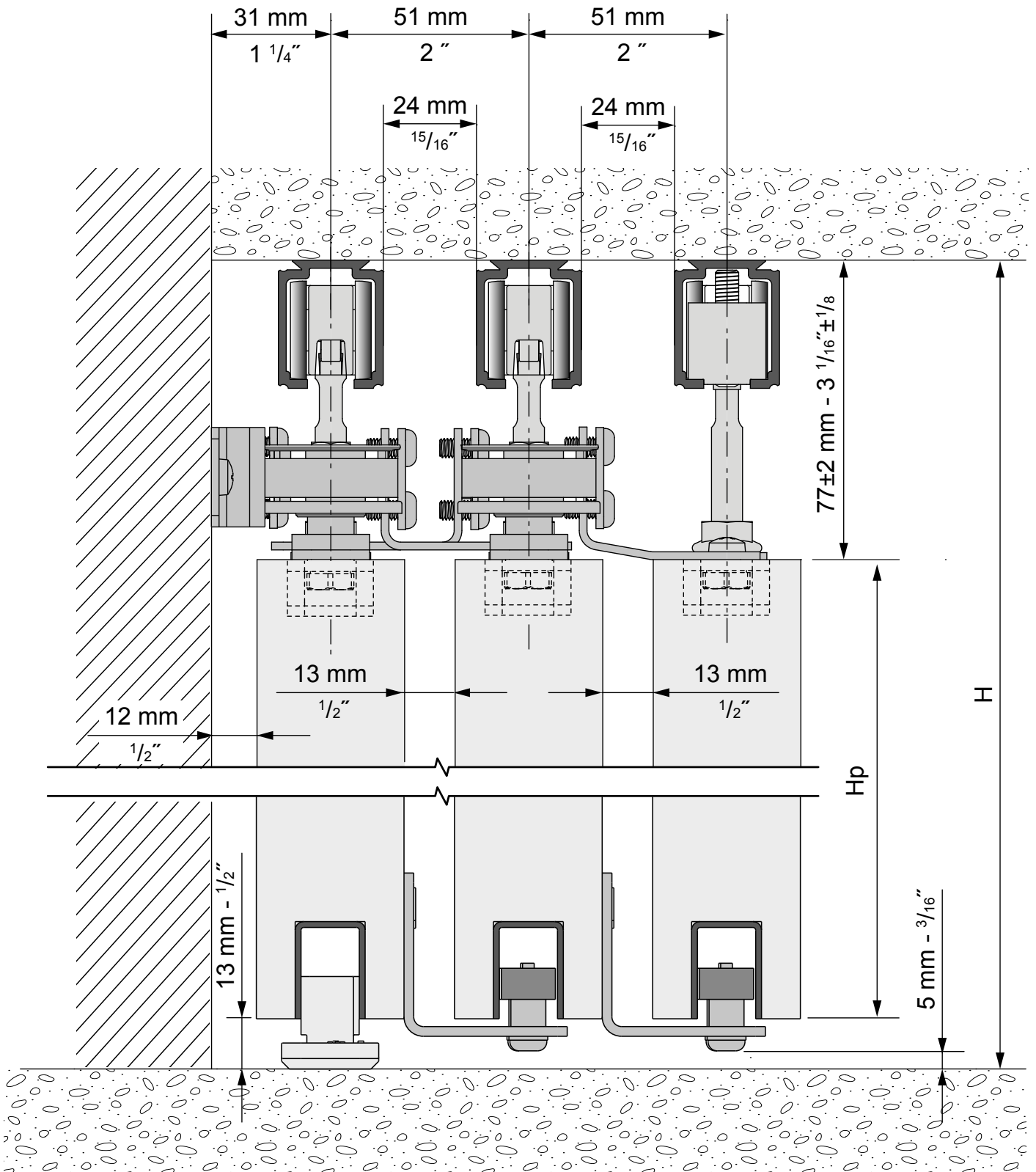

H = Hauteur de baie
 Opening height
 Öffnungshöhe
 Altura de luz

Hp = Hauteur panneaux
 Door height
 Schiebetürhöhe

$$H_p = H - 90 \text{ mm} = \text{_____ mm}$$

$$H_p = H - 3 \frac{1}{2} \text{''} = \text{_____''}$$

40 mm - 1 9/16"

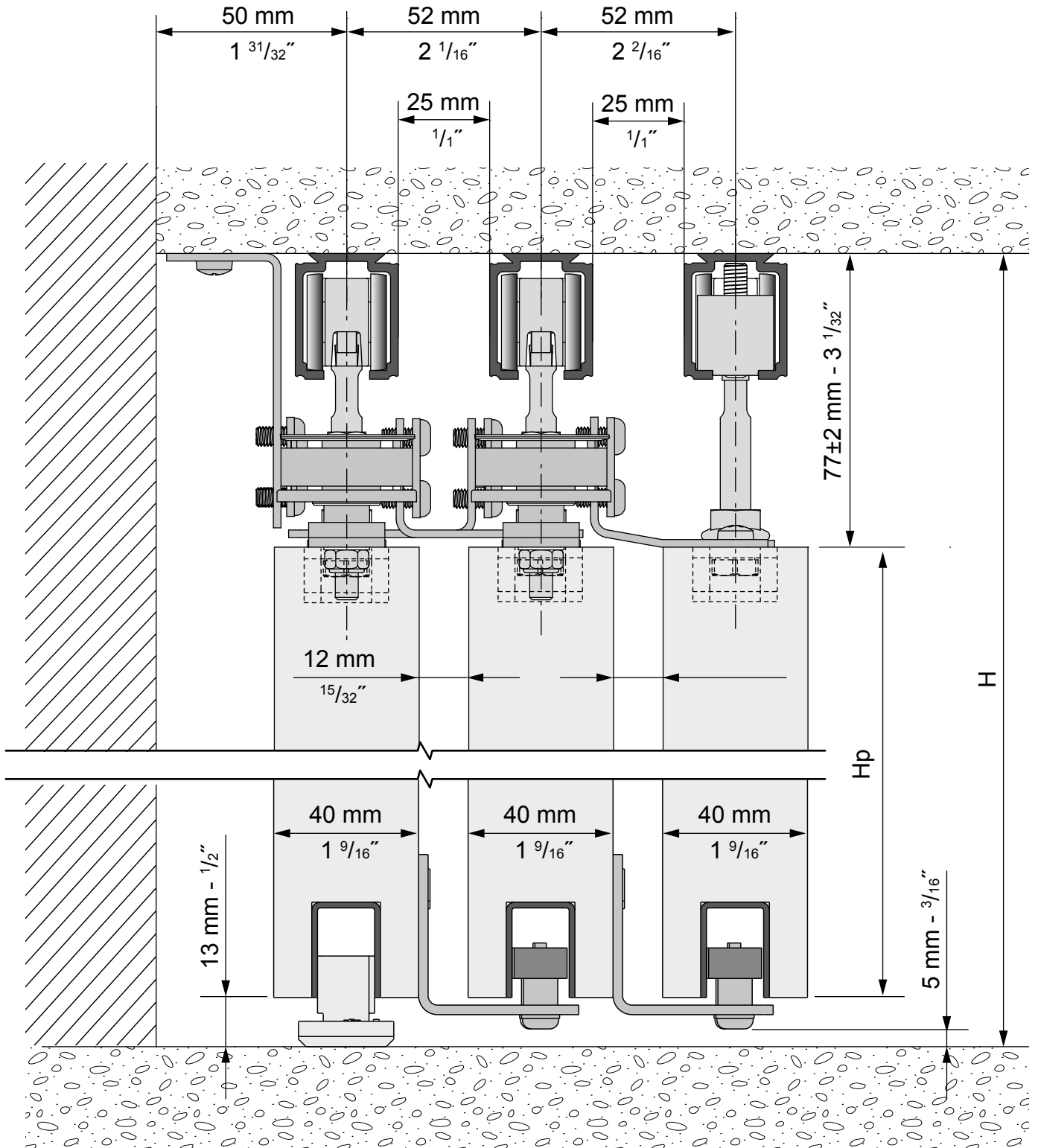

H = Hauteur de baie
 Opening height
 Öffnungshöhe
 Altura de luz

Hp = Hauteur panneaux
 Door height
 Schiebetürhöhe
 Altura de panel

$$H_p = H - 90 \text{ mm} = \text{_____ mm}$$

$$H_p = H - 3 \frac{9}{16} \text{ ''} = \text{_____ ''}$$

PLANIFICATION - PLANUNG - PLANNING - PLANIFICACIÓN



$$R = 90 \text{ mm} \quad L_p = \frac{(3 \times R) + LO}{3} = \text{_____ mm}$$

$$3 \frac{1}{2}'' \quad LR = LO + L_p = \text{_____ mm}$$

700 ≤ Lp ≤ 1500
27" ≤ Lp ≤ 59"
LR ≤ 6000
LR ≤ 235"

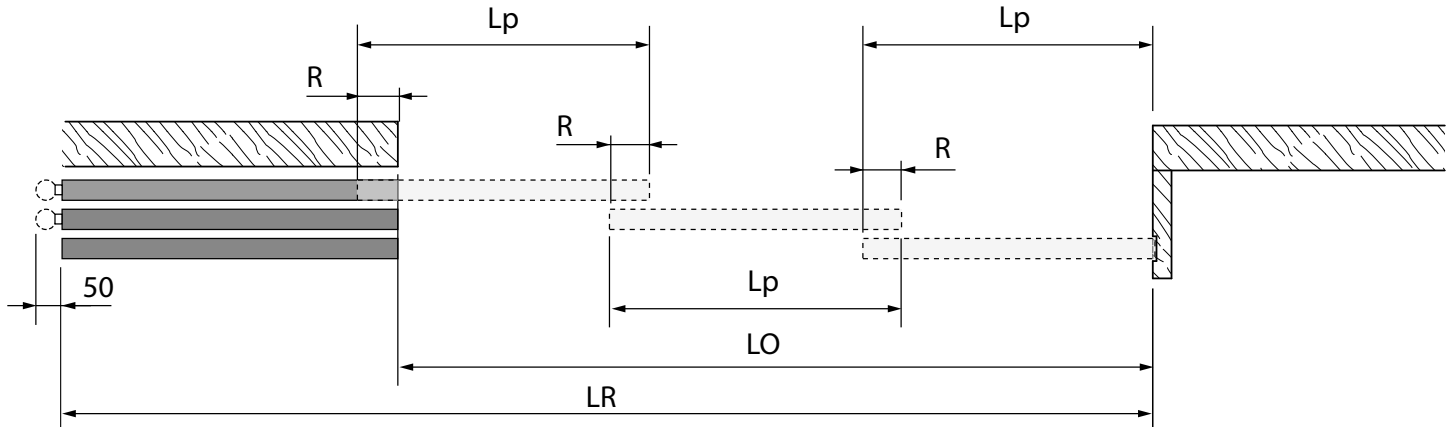

$$R = 90 \text{ mm} \quad L_{p1} = \frac{(3 \times R) + (LO - P)}{3} = \text{_____ mm}$$

$$3 \frac{1}{2}''$$

$$P = 90 \text{ mm} \quad L_{p2} = L_{p1} + P = \text{_____ mm}$$

$$3 \frac{1}{2}'' \quad LR = LO + L_{p1} = \text{_____ mm}$$

700 ≤ Lp1 ≤ 1500
27" ≤ Lp1 ≤ 59"
LR ≤ 3000
LR ≤ 235"

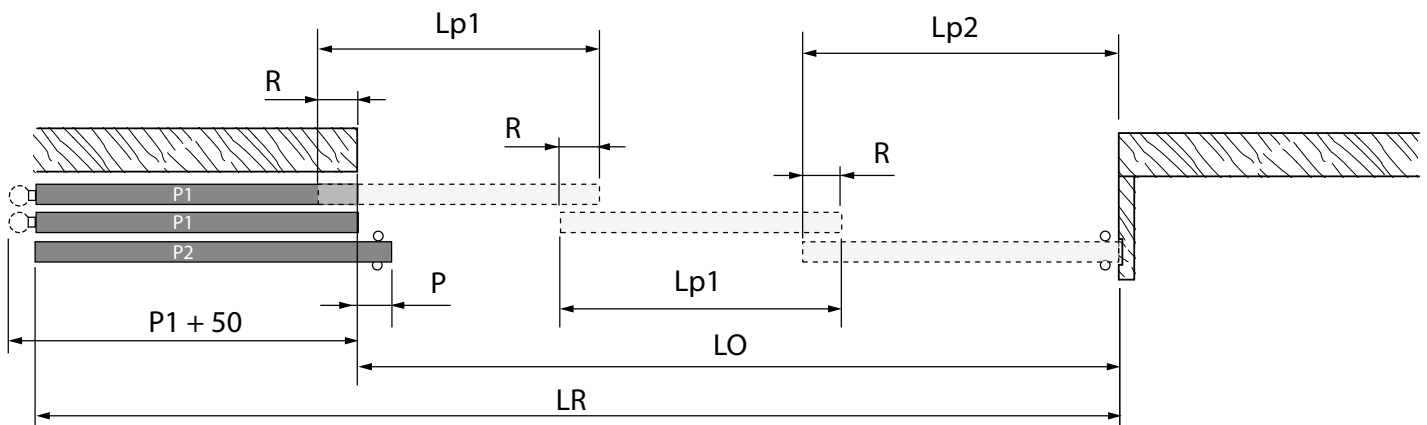

LO = Largeur de baie
Opening width
Öffnungsbreite
Ancho de luz

Lp = Largeur panneaux
Door width
Schiebetürbreite
Ancho de panel

LR = Longueur de rails
Length of tracks
Länge von Laufshienen
Longitud de los perfiles

R = Recouvrement
Door overlap
Türübershneidung
Recubrimiento

P = Poignée baton
Sliding door handle
Schiebetürgriffe
Tirador

**PRÉPARATION DES PANNEAUX - PANELS PREPARATION
VORBEREITUNG DER FLÜGEL - PREPARACIÓN DE LAS HOJAS**

1.

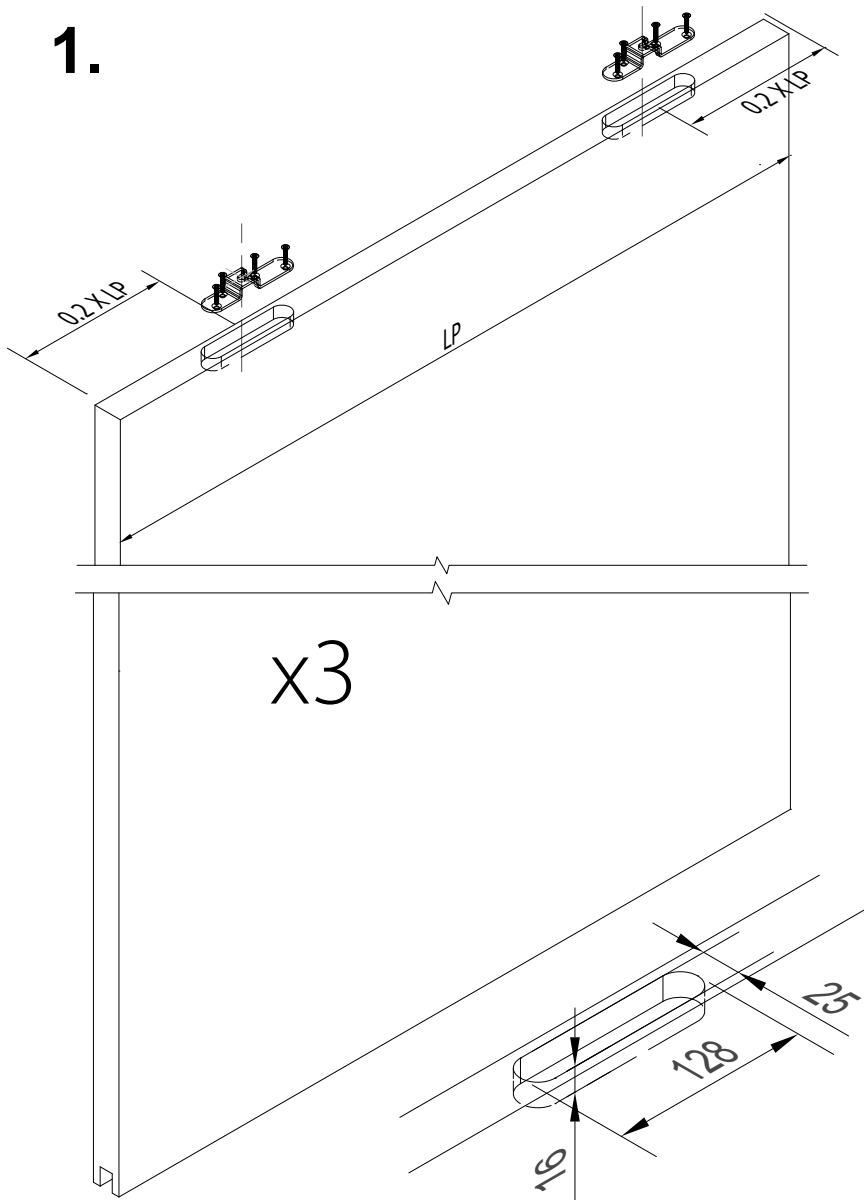

1109 A

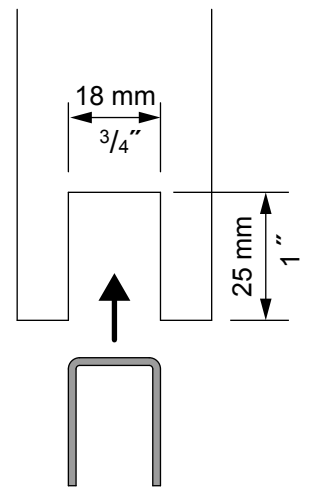

1109

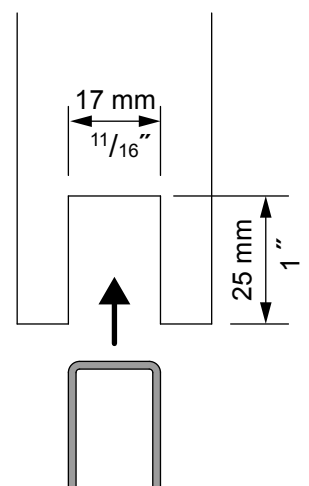

2.

x4

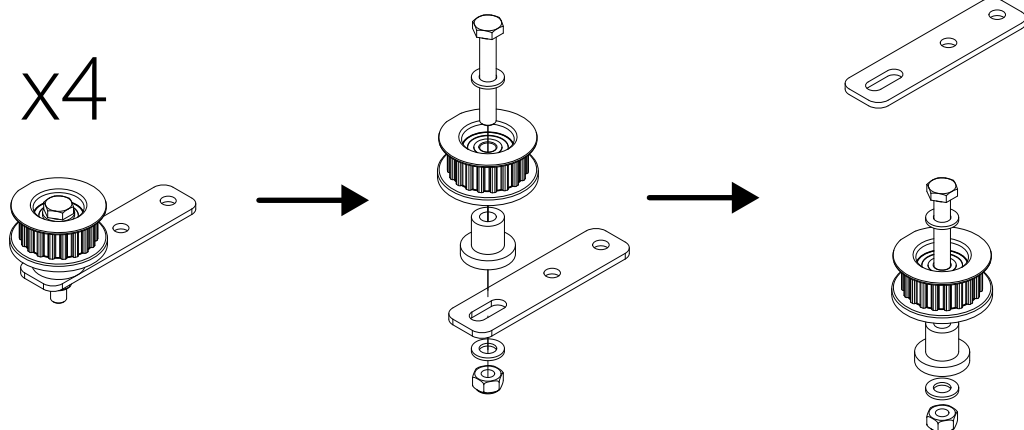

**PRÉPARATION DES PANNEAUX - PANELS PREPARATION
VORBEREITUNG DER FLÜGEL - PREPARACIÓN DE LAS HOJAS**

3.

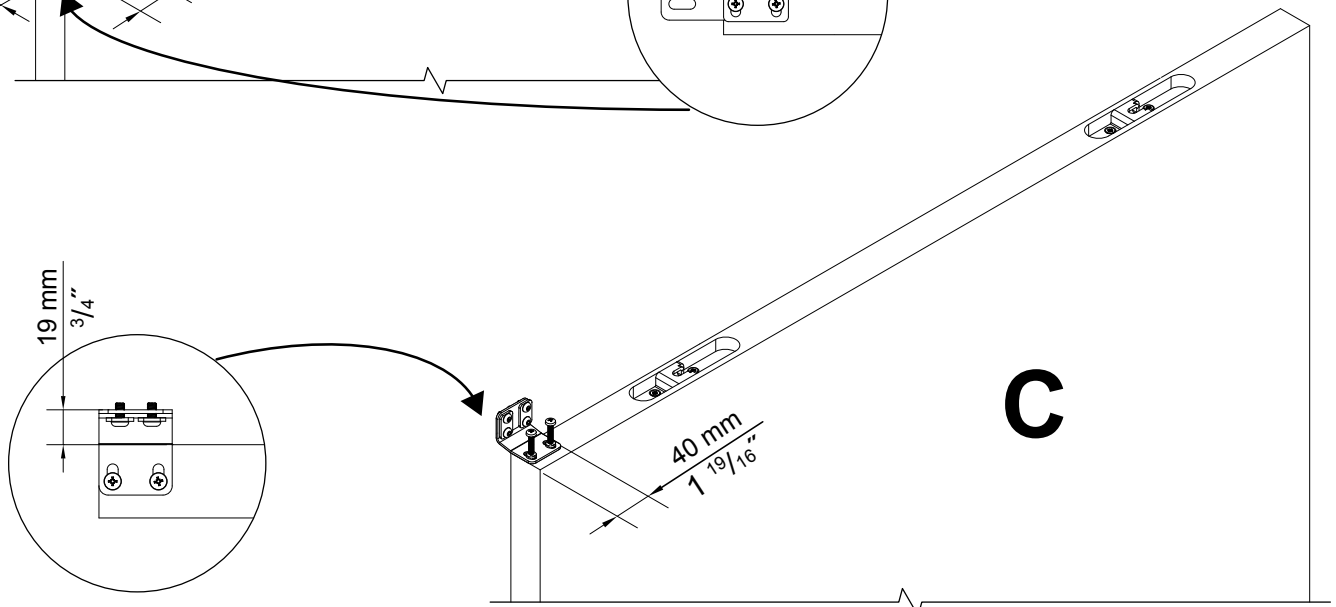
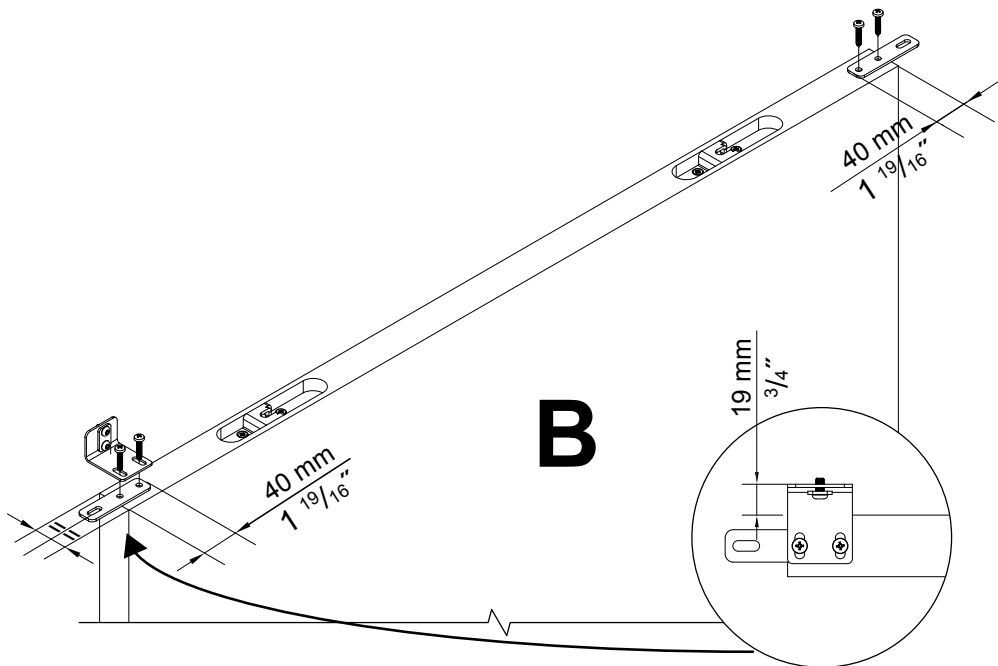
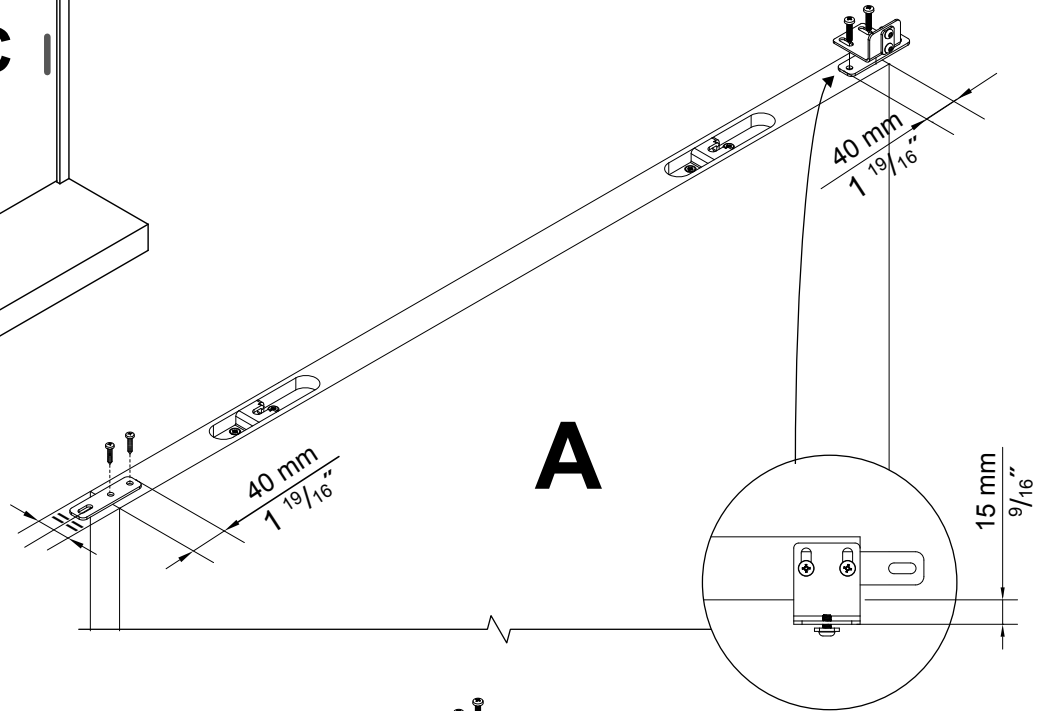
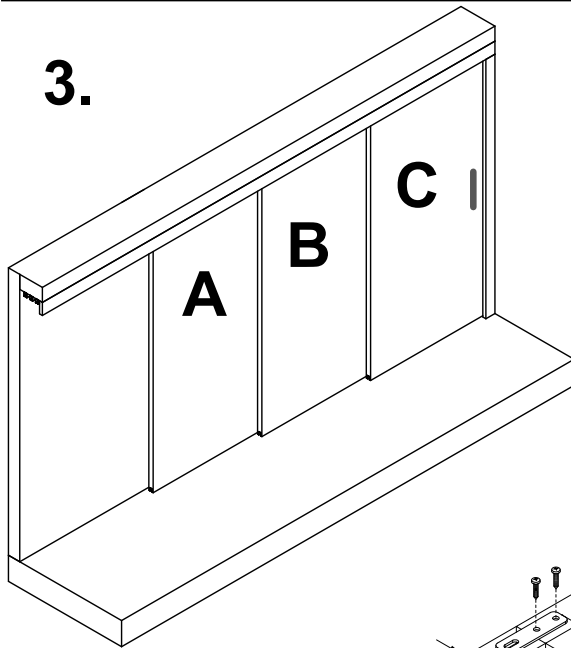

MONTAGE - INSTALLATION - MONTAJE

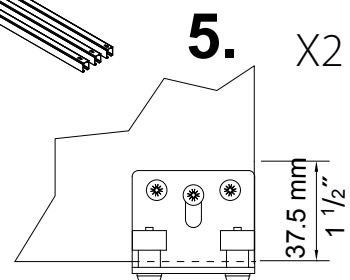
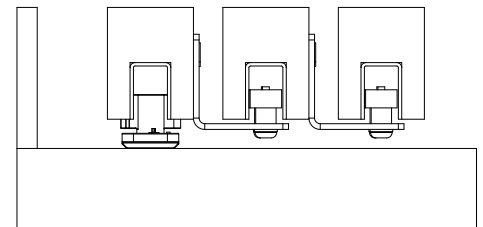
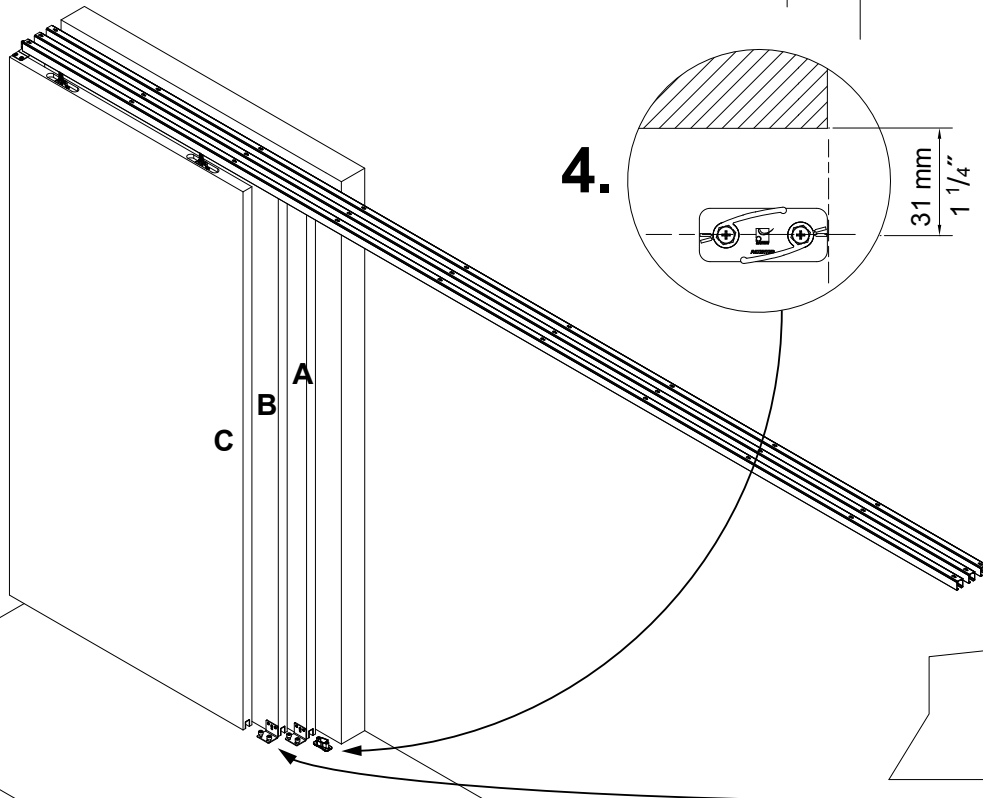
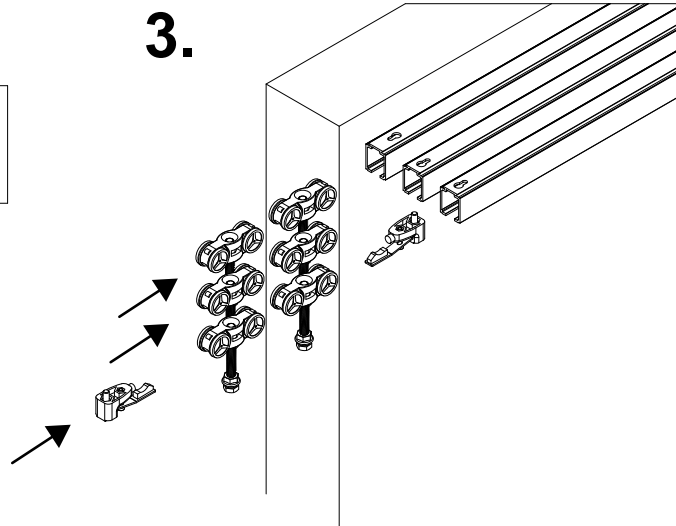
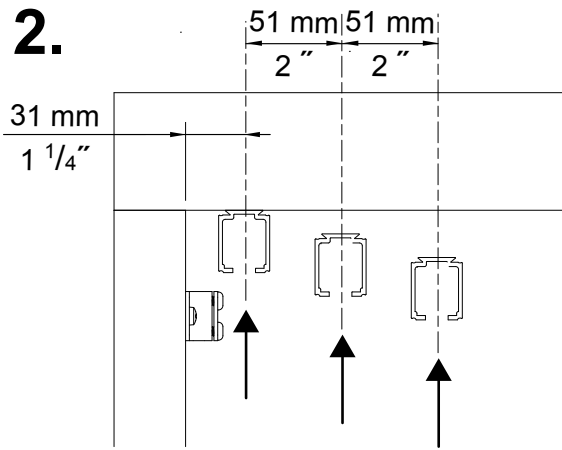
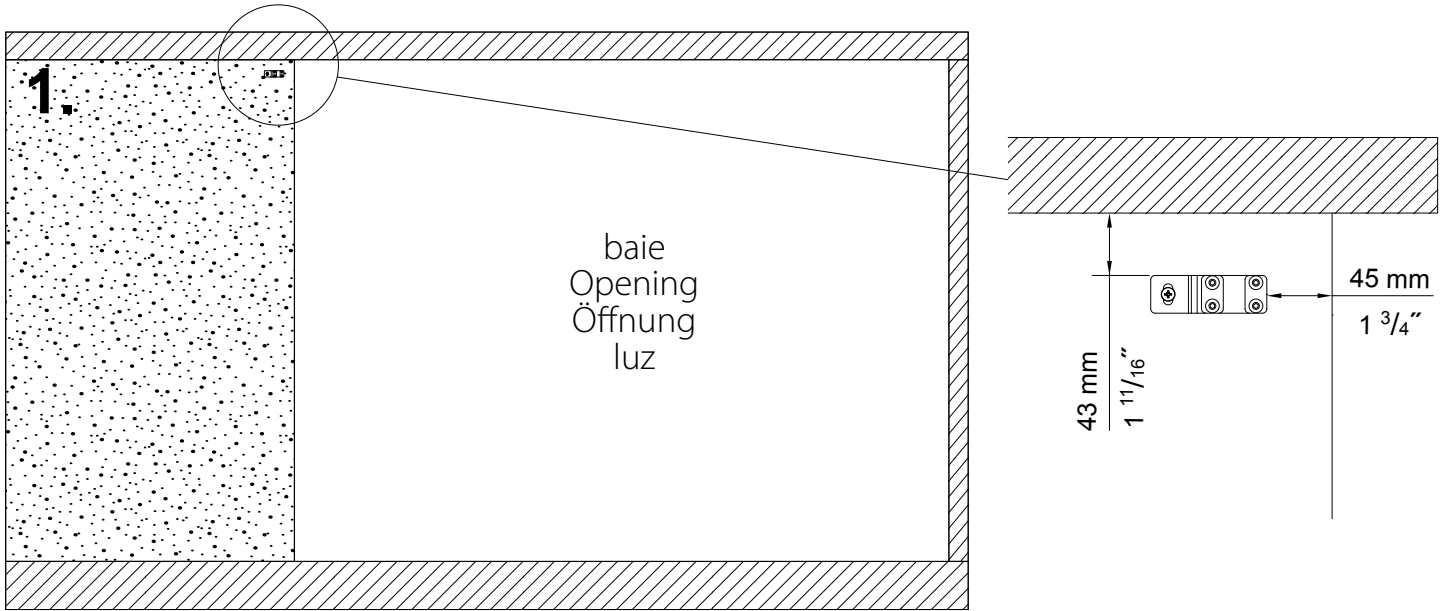

6.

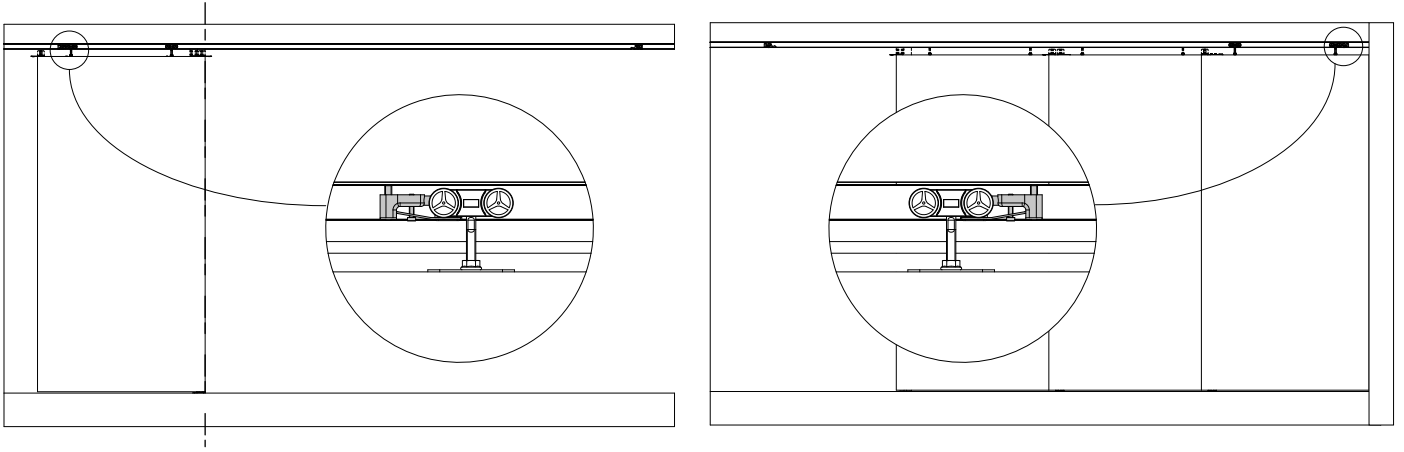

7.

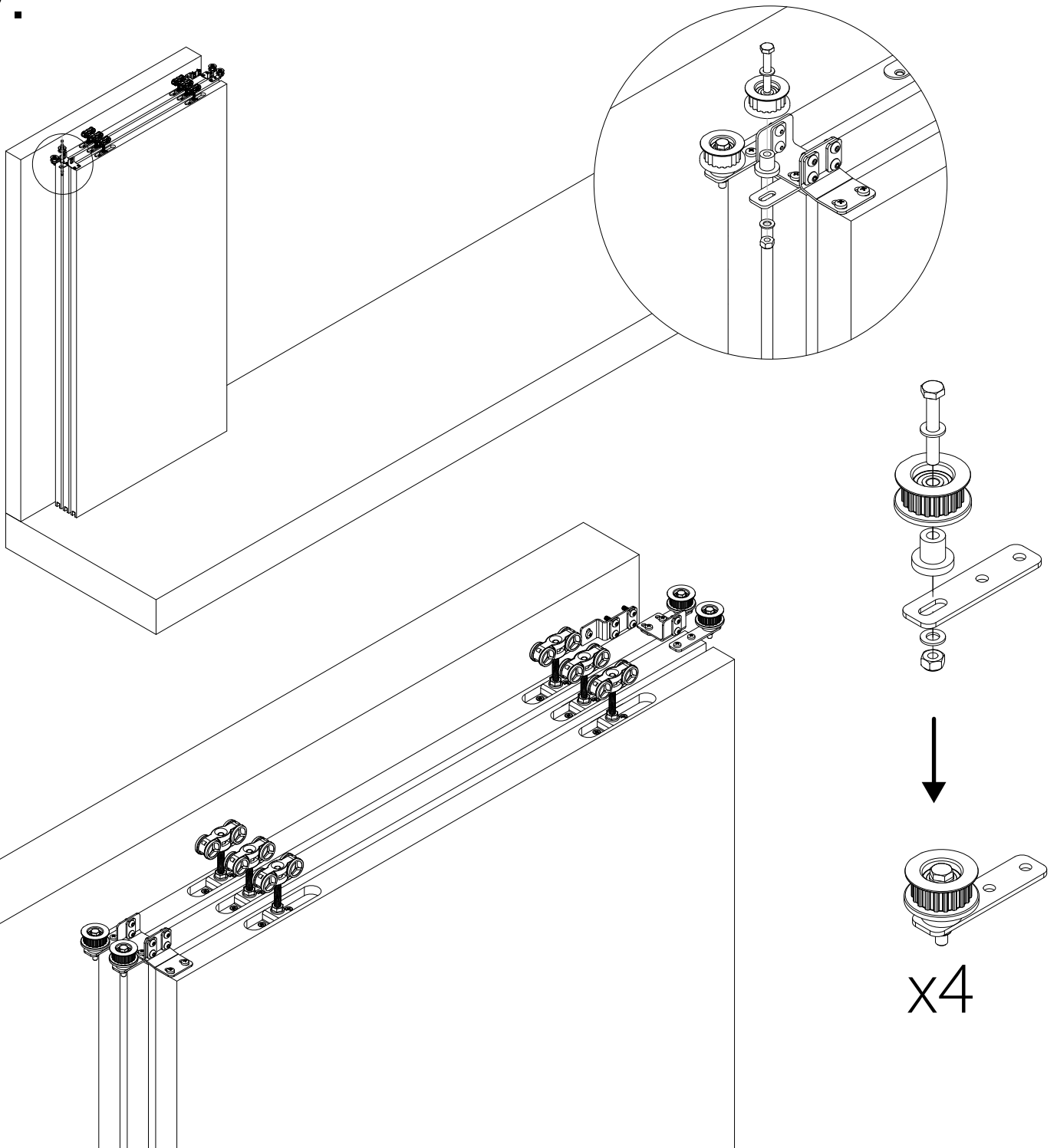

8.

