



INSTRUCTION DE MONTAGE
MONTAGEANLEITUNG
INSTRUCTIONS FOR ASSEMBLY
INSTRUCCIONES DE MONTAJE

SAF-INSIDE

NM_SAFIN_003

PORTE ENTRE-CLOISONS: 1 PORTE MANUELLE
KASTENRAHMENSYSTEM FÜR SCHIEBETÜR : 1 HANDTÜR
POCKETDOOR – 1 MANUAL DOOR
PUERTA ENTRE TABIQUE : 1 HOJA MANUAL

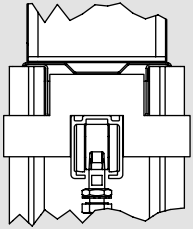

DEPLACEMENT MANUEL
ANTRIEB: MANUELL
MANUAL MOVE
MOVIMIENTO MANUAL

Poids maximal des panneaux
Maximales Gewicht
Maximum weight
Peso máximo por hoja

80 Kg

Epaisseur des panneaux
Ladendicke
Shutter thickness
Espesor de las hojas

8 mm



COMPOSITION - ZUSAMMENSETZUNG - COMPOSICIÓN

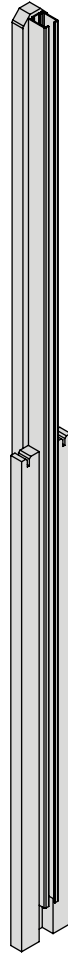
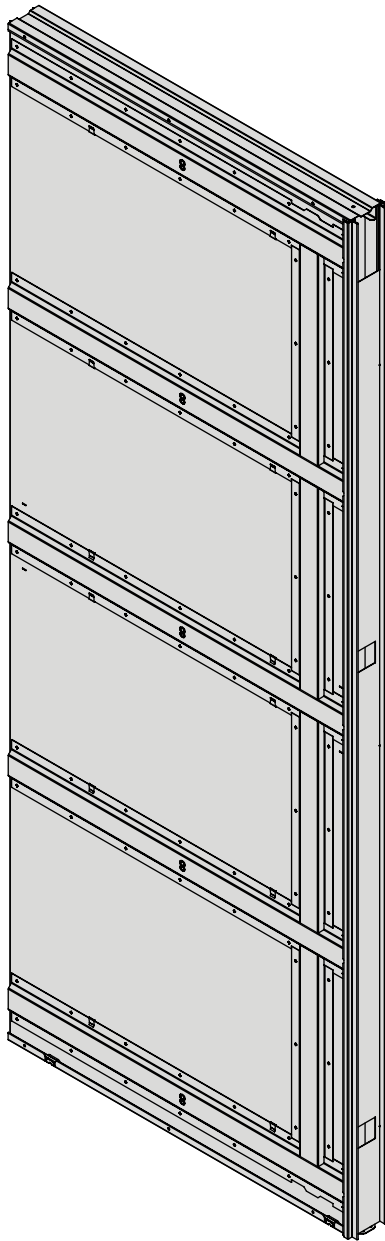

x2

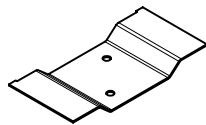

x2

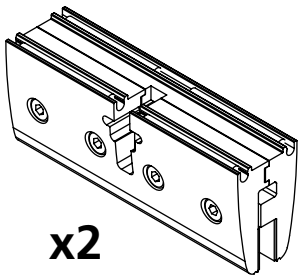

x2

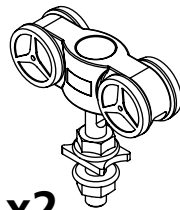

x2

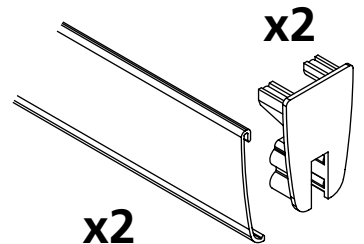
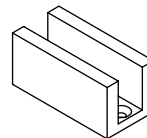
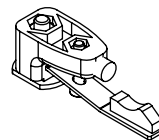
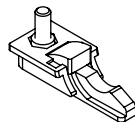

x2

x2

**ENCOMBREMENT / ABMESSUNGEN
DIMENSIONS / VOLUMEN**

Ref. / Art.Nr Item Nr	LT (mm)	LO (mm) Min / Max
SAF-INSIDE 700	1510	695
SAF-INSIDE 800	1710	795
SAF-INSIDE 900	1910	895
SAF-INSIDE 1000	2110	995

dimensions des portes Abmessungen von Türen dimensions of doors Dimensiones de las puertas	
L (mm) Min / Max	W (mm)
735	2015
835	2015
935	2015
1035	2015

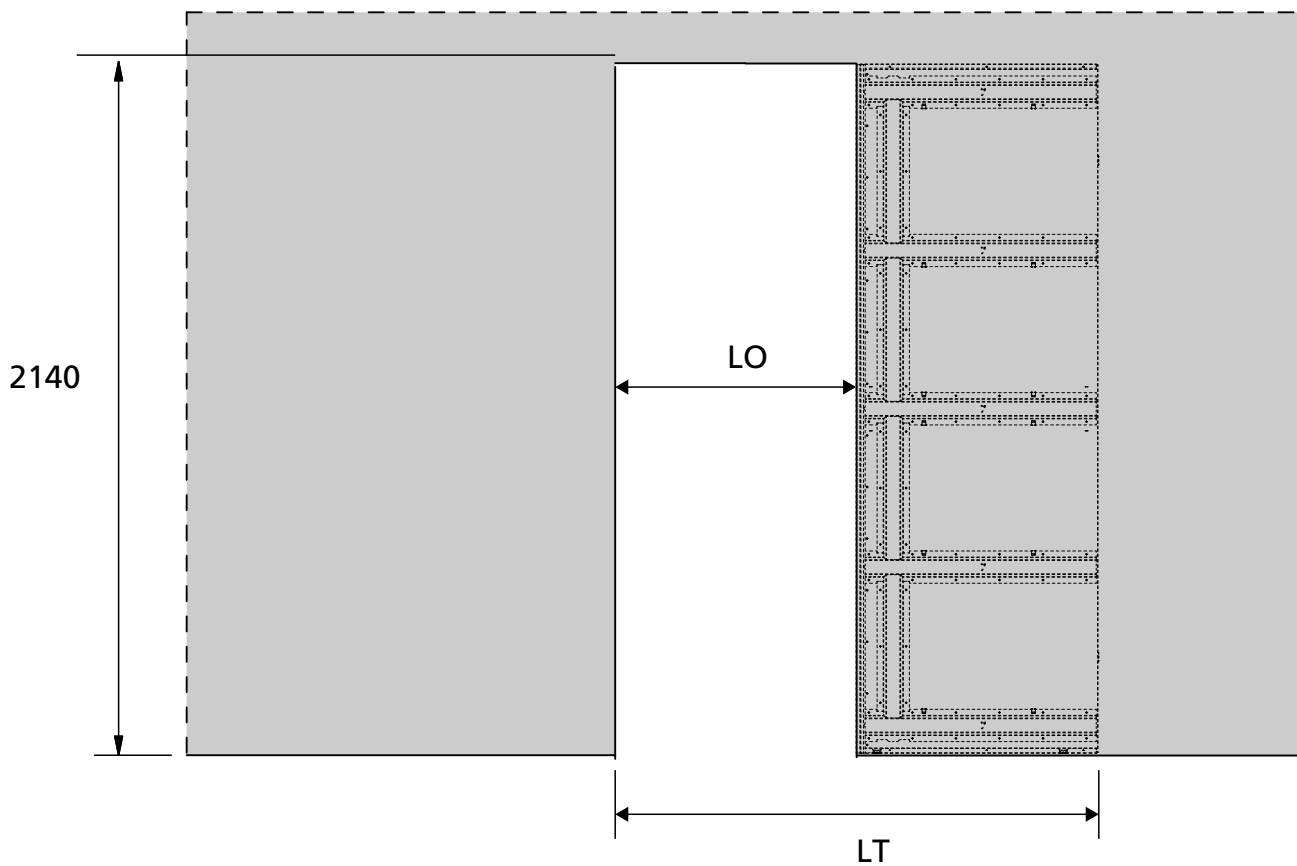
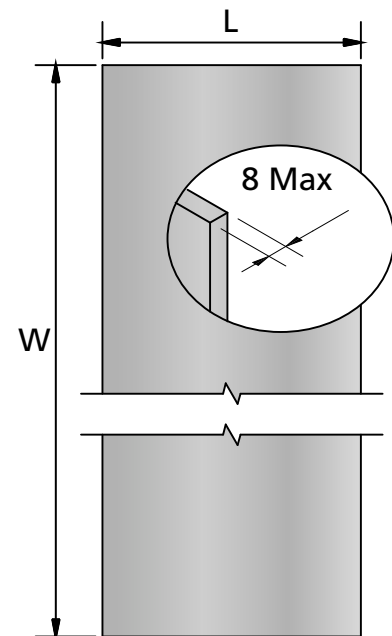

IMPORTANT: Produit destiné à une utilisation en intérieur. Ne pas installer dans des endroits humides.
WICHTIG: Dieses Produkt ist nur für Innenanwendung geeignet.
 Nicht in feuchten Atmosphären verwenden
WARNING: For indoor use only. Do not install in humid places
IMPORTANTE: Producto con destinación en el interior. No instalar en lugares húmedos



IMPORTANT: Si la butée n'est pas mise en place à cette étape, il ne sera pas possible de la fixer par la suite.
WICHTIG: Der Endwinkel muss unbedingt in diesem Augenblick befestigen, es wird ganz nicht möglich später sein.
WARNING: The stop must be set at this moment because it will not be possible later.
IMPORTANTE: Si no se ha montado el tope ahora, será imposible colocarlo luego

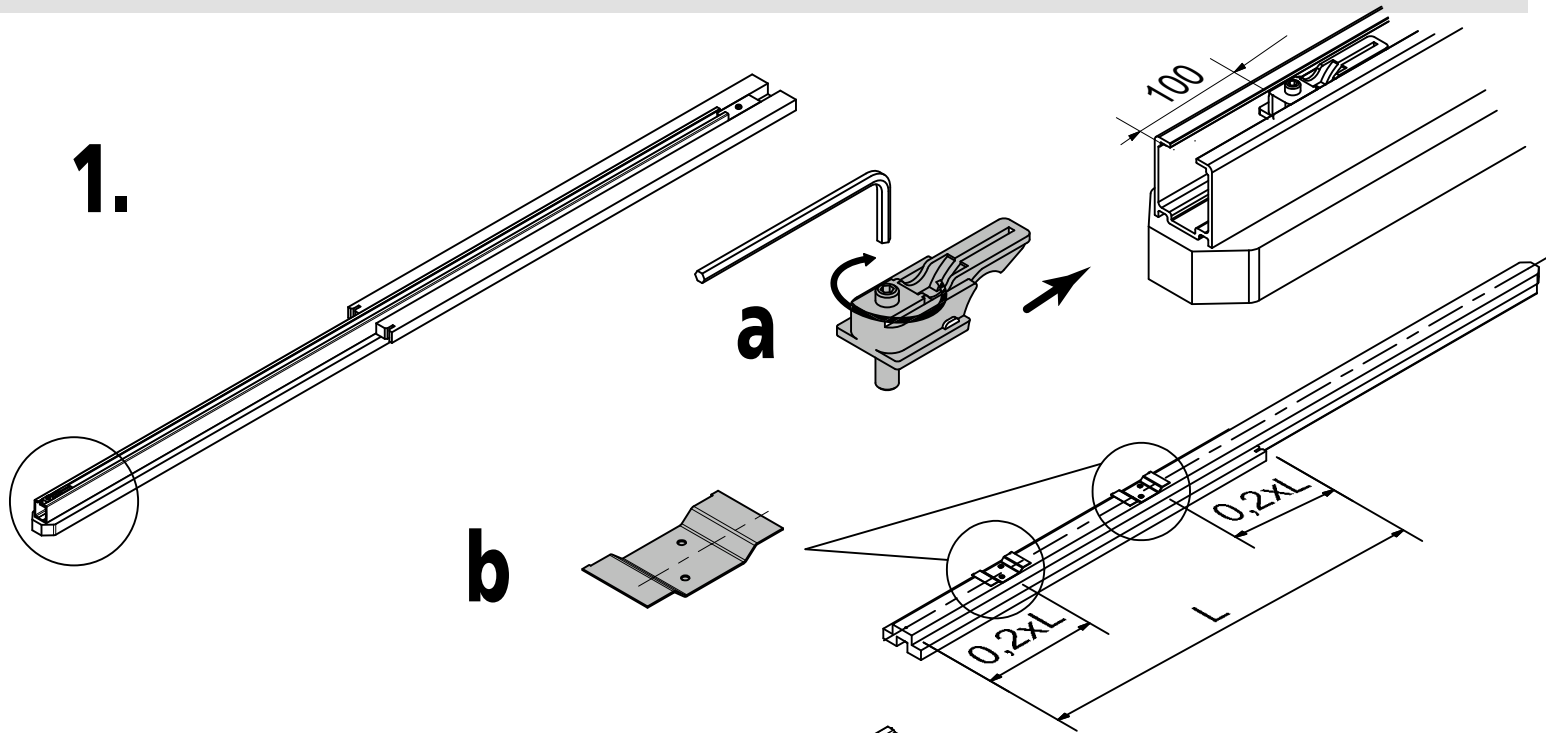

2.

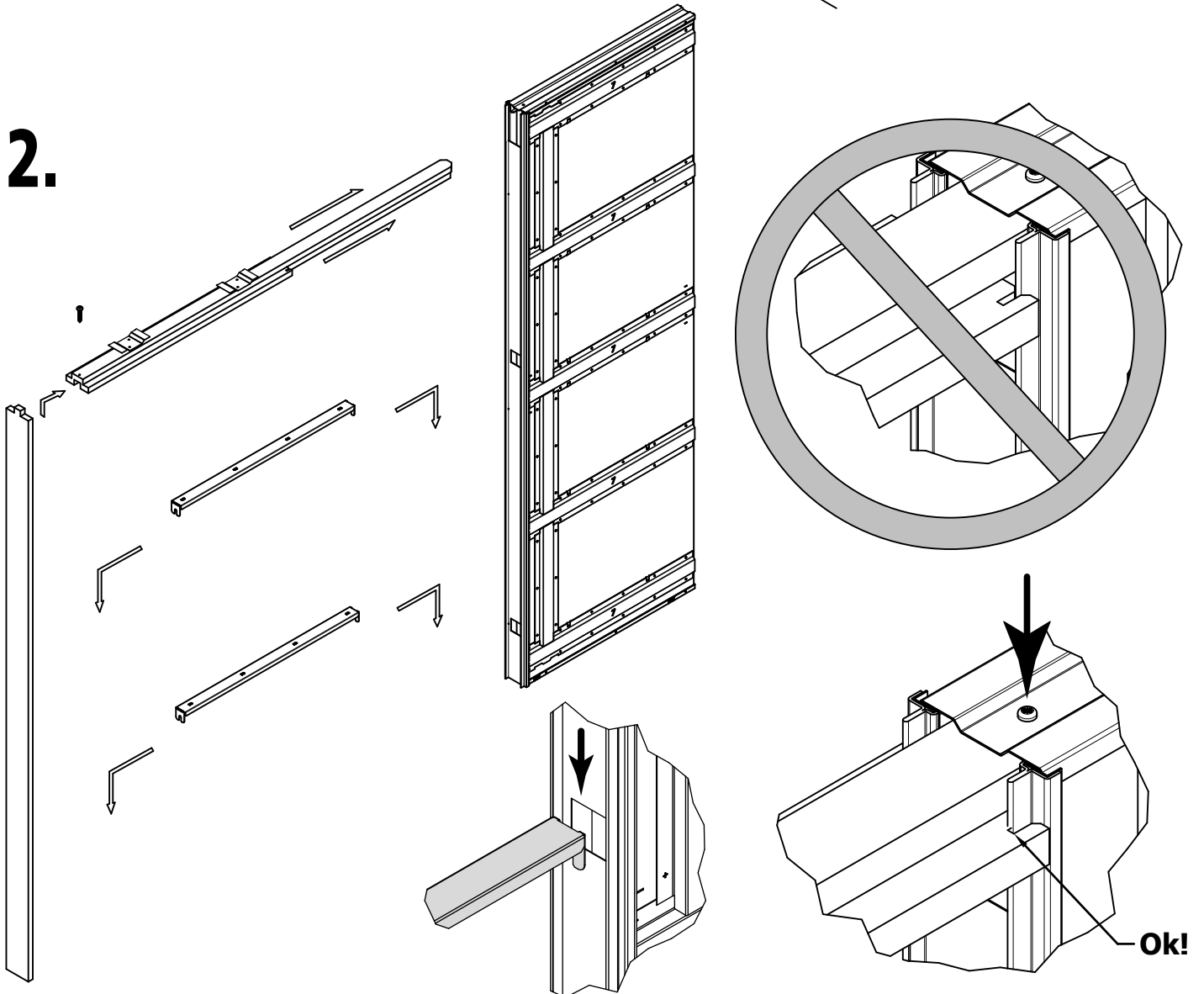

3.

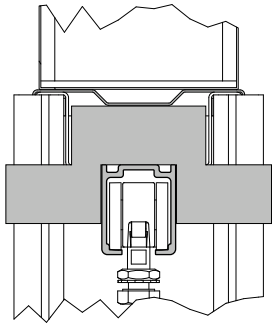

Accessoires de fixation non fournis
 Fixing accessories not supplied
 Befestigungszubehör nicht geliefert
 Accesorios de fijación no suministrados

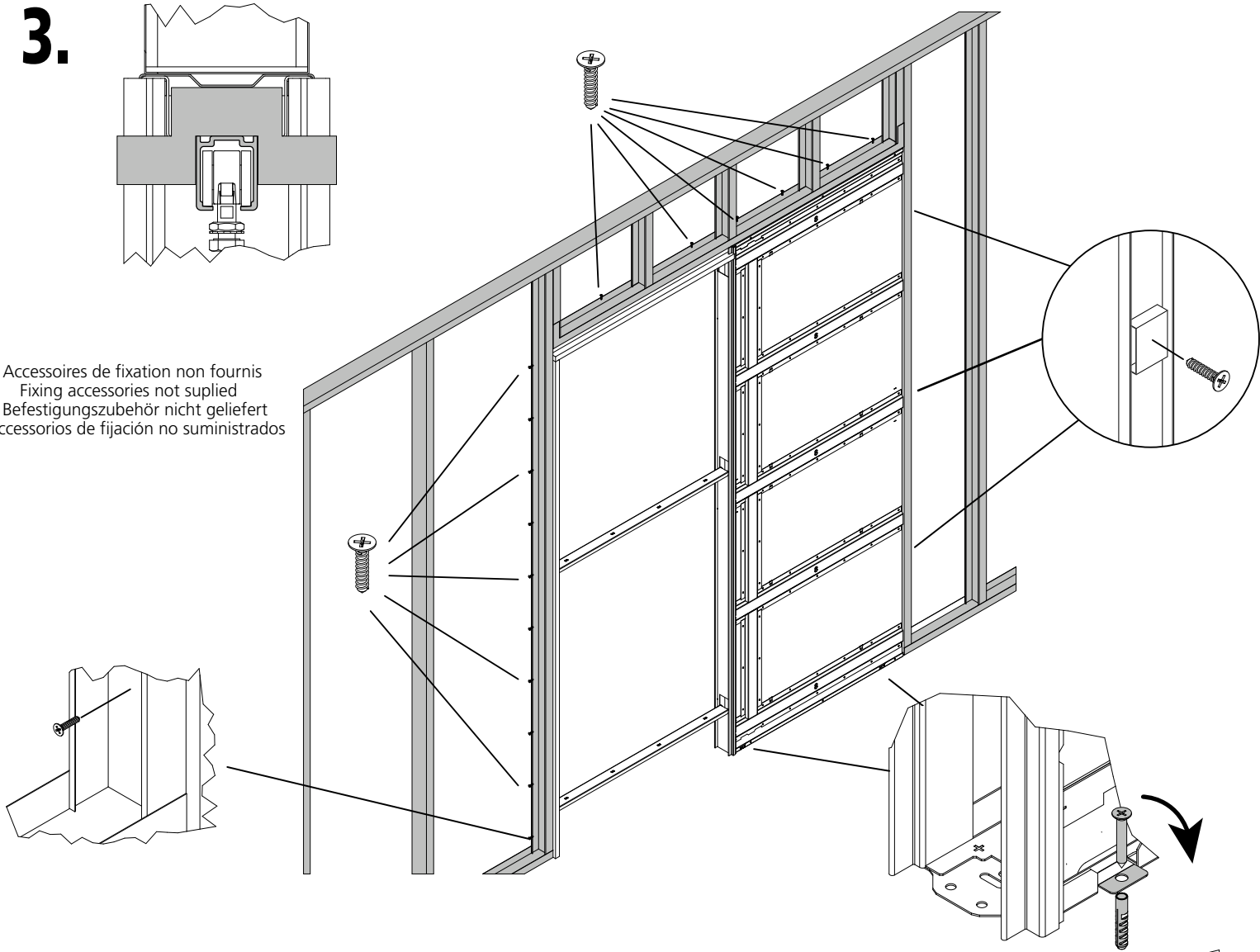

4.

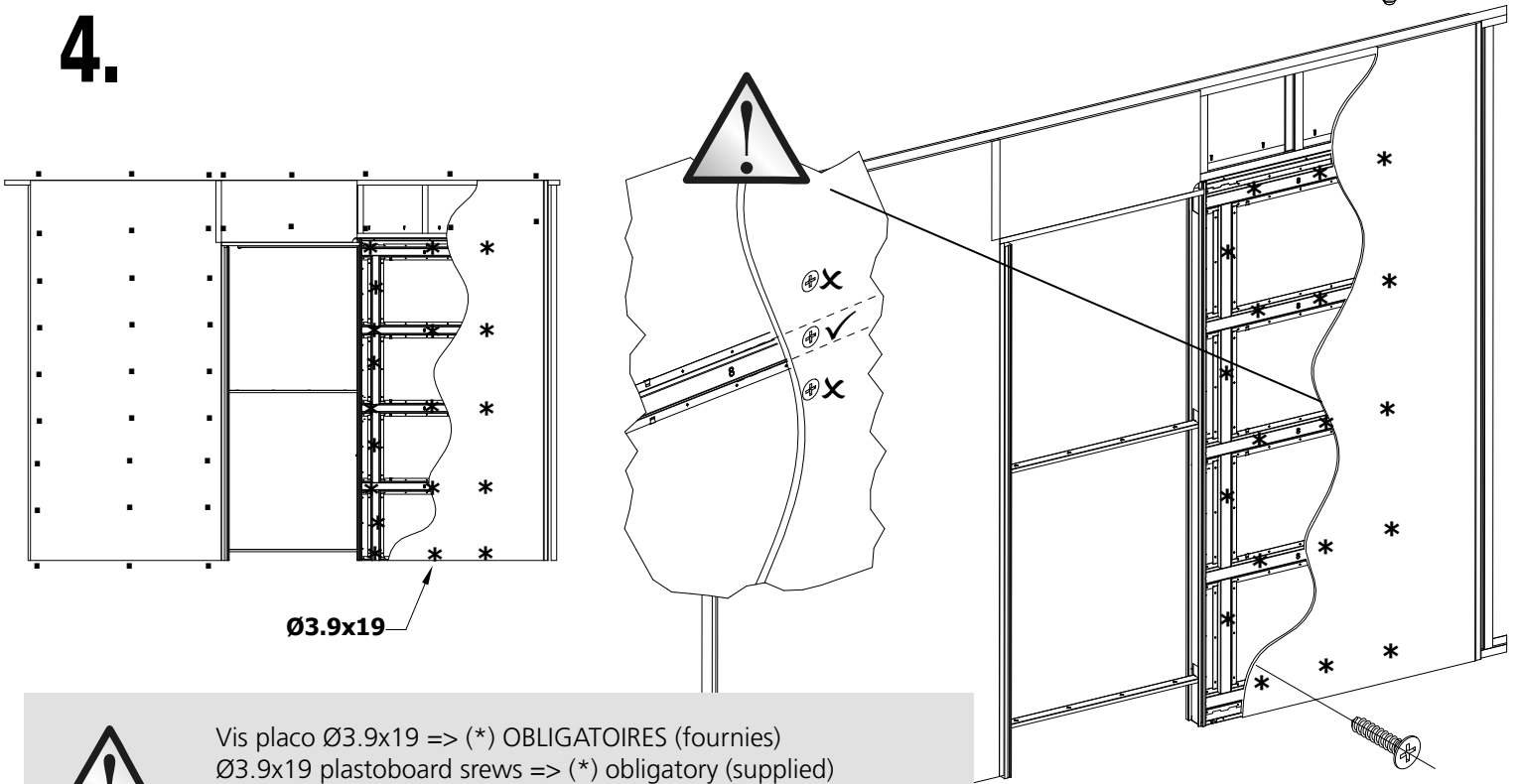

Ø3.9x19

x40



Vis placo Ø3.9x19 => (*) OBLIGATOIRES (fournies)
 Ø3.9x19 plastoboard screws => (*) obligatory (supplied)
 Ø3.9x19 GSP Schrauben Bindend (geliefert)
 Tornillo para pladur Ø3.9x19 => (*) IMPERATIVO (suministrados)



IMPORTANT: Retirer intégralement les cales collées à l'intérieur du caisson.

WICHTIG: Take back all the wedges fixed inside the frame.

WARNING: Anheben die ganze beklebt Keile in dem Rahmen.

IMPORTANTE: Quitar integralmente los calces pegados en el interior del cajón.

5.

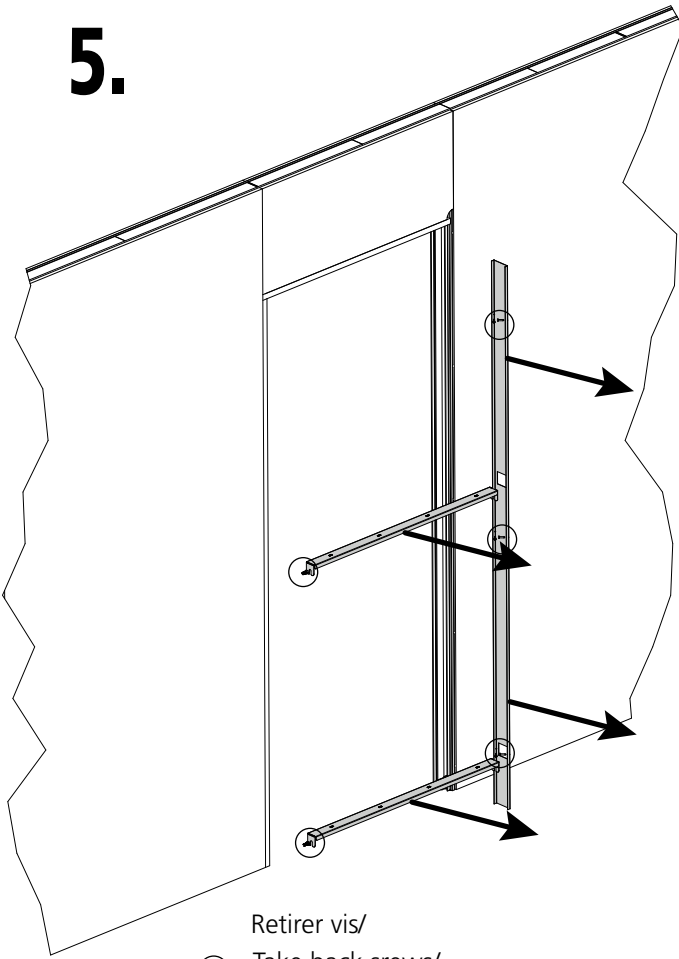

Retirer vis/

- Take back screws/
Schrauben anheben/
Quitar los tornillos

6.

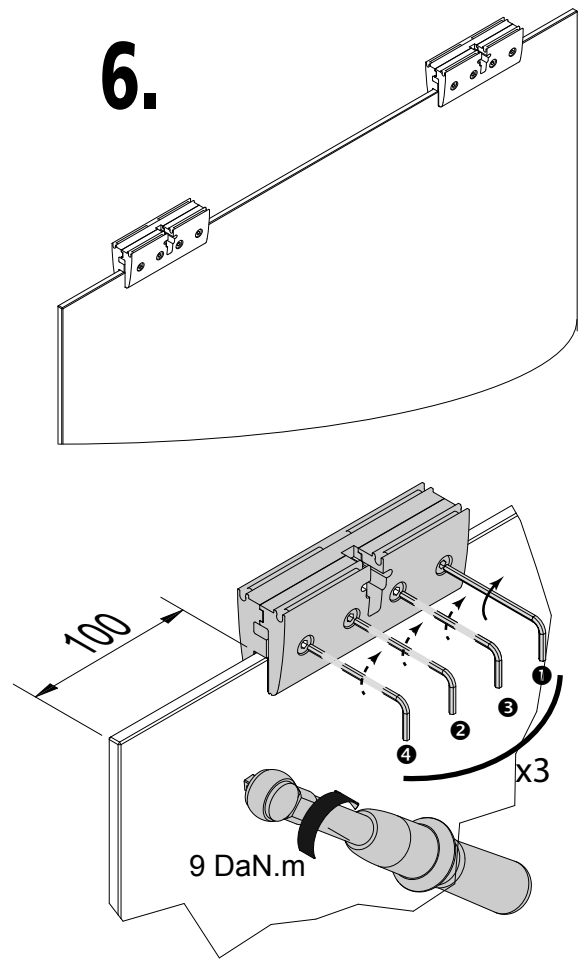

7.



a

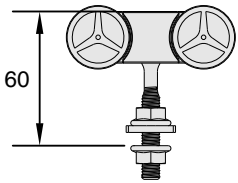

c

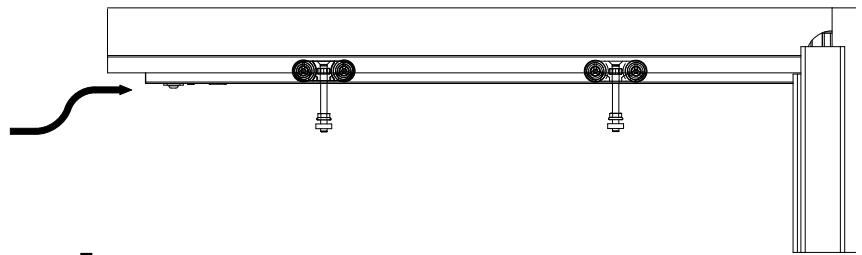
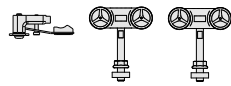

d

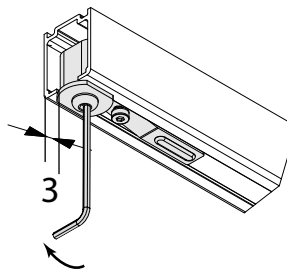

e

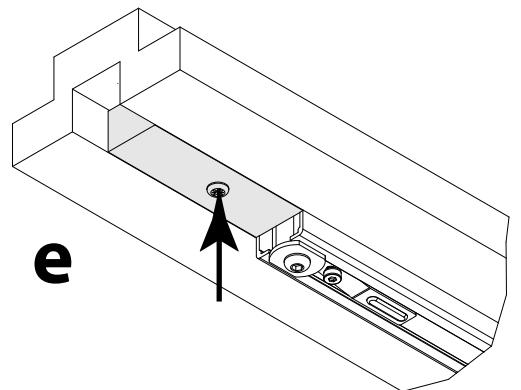

8.

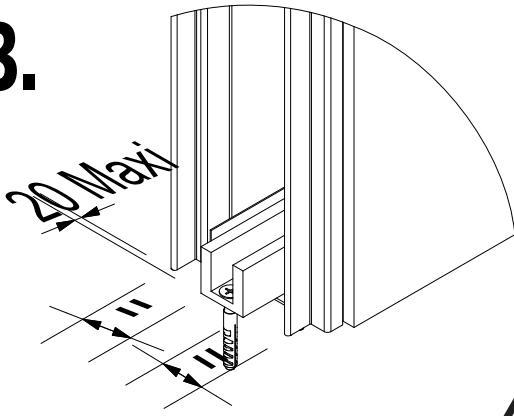

9.

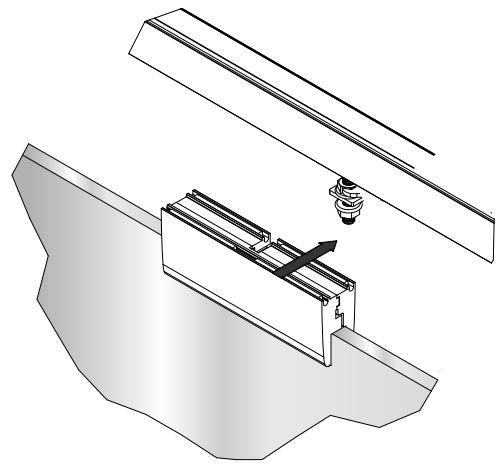

Réglage
Einstellung
Adjustment
Ajuste

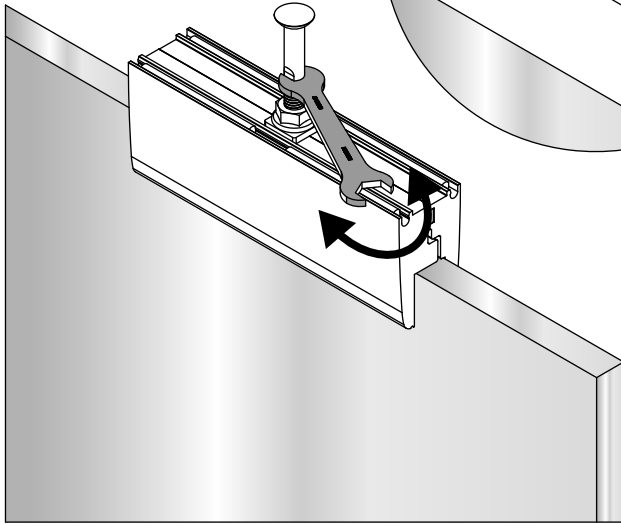
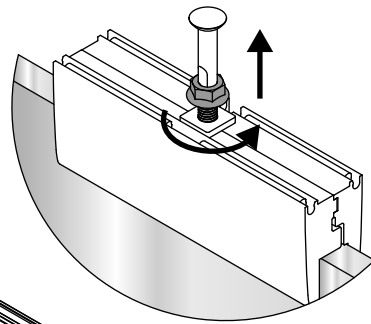

Serrage
Klemmen
Fitting
Apriete

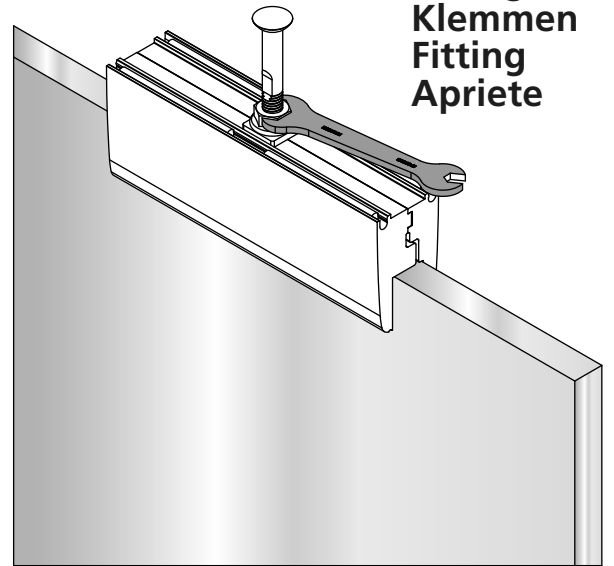

10.

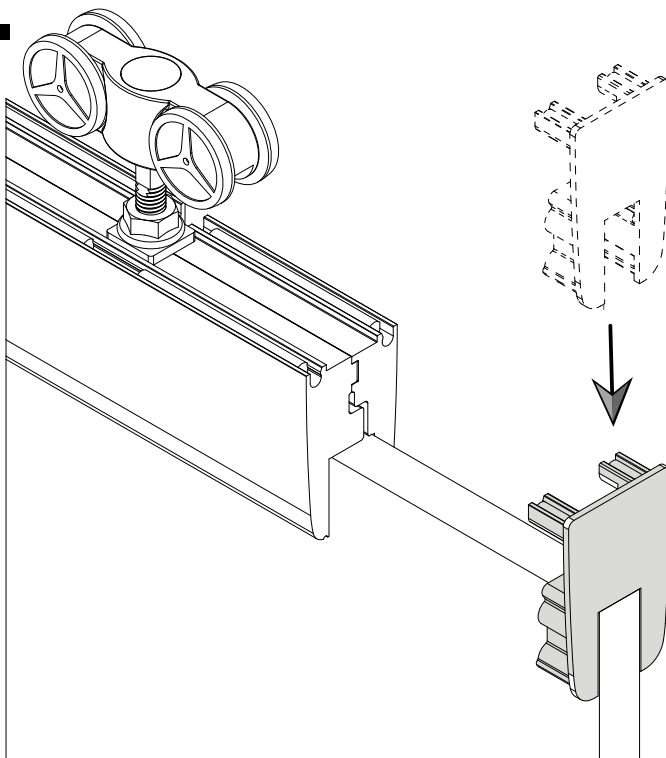

11.

