



INSTRUCTION DE MONTAGE
MONTAGEANLEITUNG
INSTRUCTIONS FOR ASSEMBLY
INSTRUCCIONES DE MONTAJE

SAF-INSIDE

NM_SAFIN_002

PORTE ENTRE-CLOISONS: 2 VANTAUX MANUELS
KASTENRAHMENSYSTEM FÜR SCHIEBETÜR : 2 HANDTÜRFLÜGELS
POCKETDOOR – 2 MANUALS LEAFS
PUERTA ENTRE TABIQUE : 2 HOJAS MANUALES

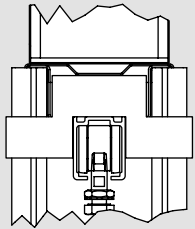

DEPLACEMENT MANUEL
ANTRIEB: MANUELL
MANUAL MOVE
MOVIMIENTO MANUAL

Poids maximal des panneaux
Maximales Gewicht
Maximum weight
Peso máximo por hoja

80 Kg

Epaisseur des panneaux
Ladendicke
Shutter thickness
Espesor de las hojas

40 mm



COMPOSITION - ZUSAMMENSETZUNG - COMPOSICIÓN

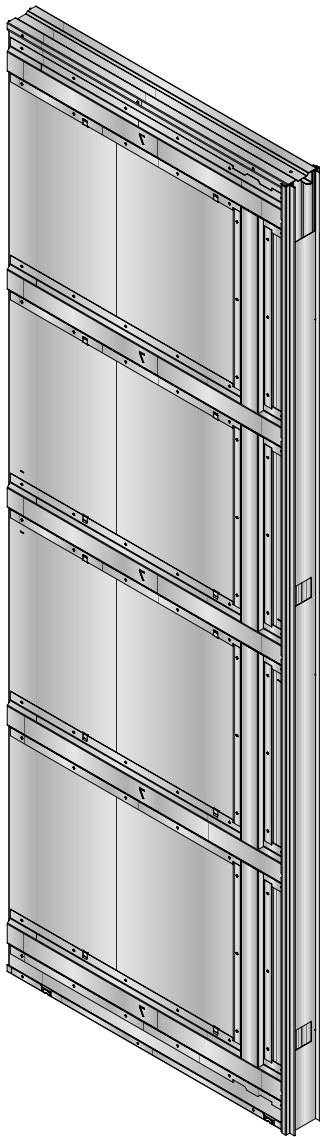

+

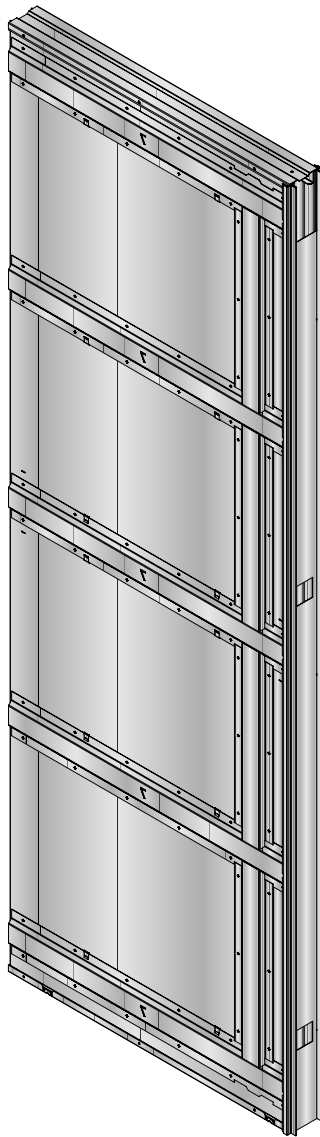

+

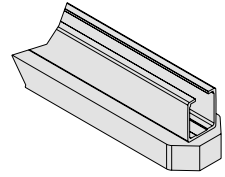

x2

Ref. / Art.Nr Item Nr	L (mm)
SAF-INSIDE 140	1347
SAF-INSIDE 100	1547
SAF-INSIDE 180	1747
SAF-INSIDE 200	1947

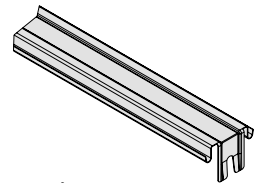

x2

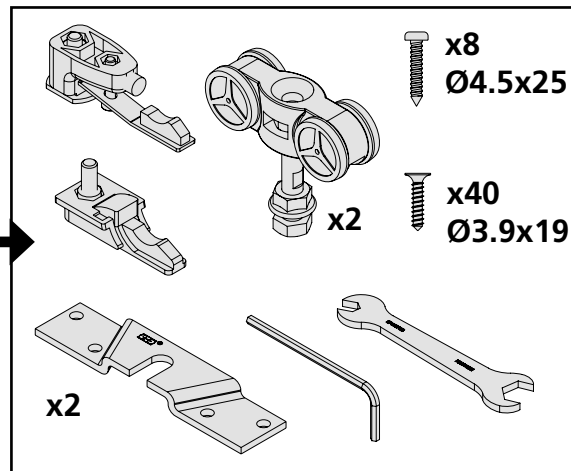
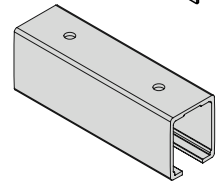
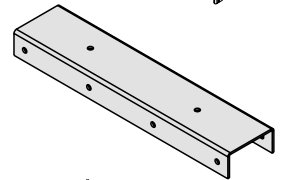

+

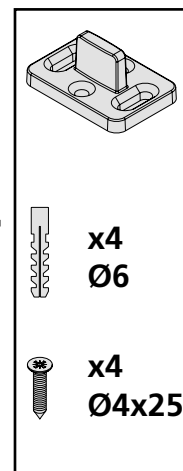

+

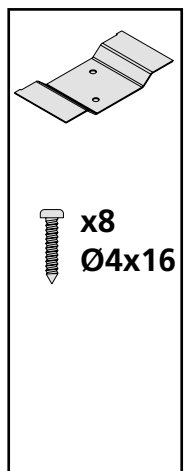

OPTION
SYNCHRONISATION
Ref. 11050-2

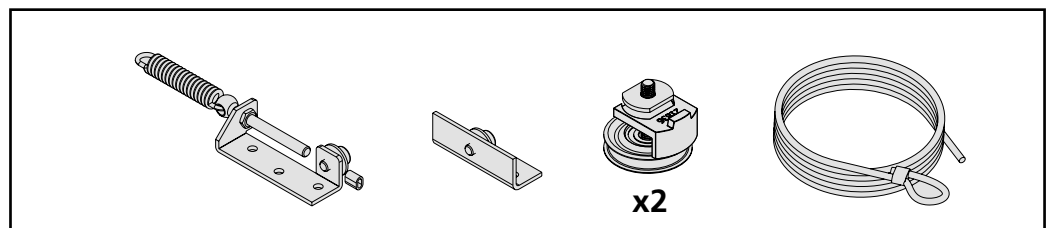

**ENCOMBREMENT / ABMESSUNGEN
DIMENSIONS / VOLUMEN**

Ref. / Art.Nr Item Nr	LT (mm)	LO (mm) Min / Max
SAF-INSIDE 140	2915	1385
SAF-INSIDE 160	3315	1585
SAF-INSIDE 180	3715	1785
SAF-INSIDE 200	4115	1985

dimensions des portes Abmessungen von Türen dimensions of doors Dimensiones de las puertas	
L (mm) Min / Max	W (mm)
730	2040
830	2040
930	2040
1030	2040

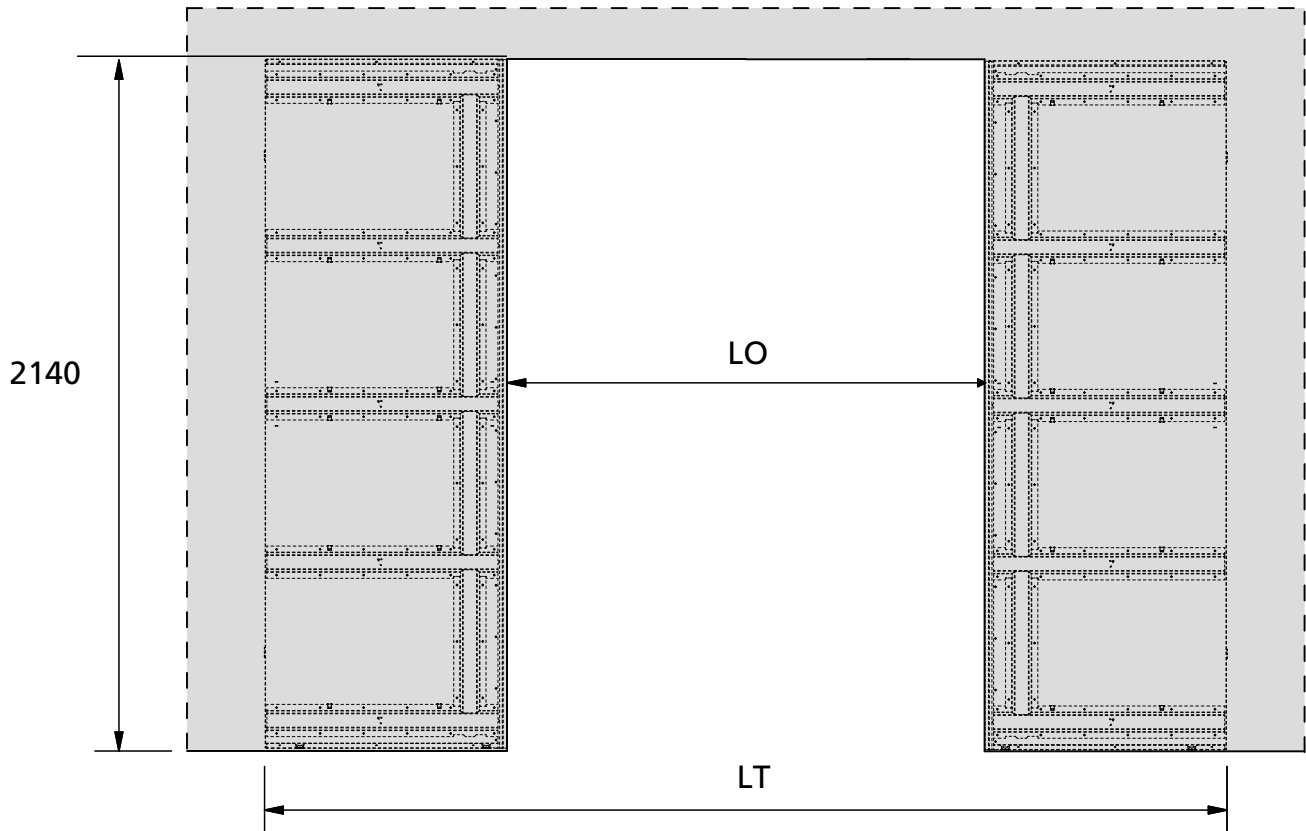
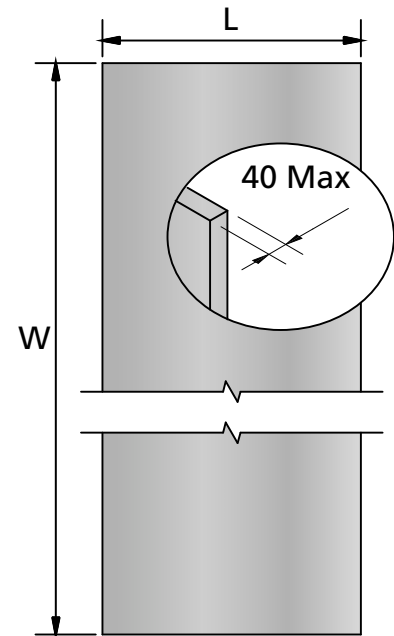

IMPORTANT: Produit destiné à une utilisation en intérieur. Ne pas installer dans des endroits humides.
WICHTIG: Dieses Produkt ist nur für Innenanwendung geeignet.
 Nicht in feuchten Atmosphären verwenden
WARNING: For indoor use only. Do not install in humid places
IMPORTANTE: Producto con destinación en el interior. No instalar en lugares húmedos



IMPORTANT: Si la butée n'est pas mise en place à cette étape, il ne sera pas possible de la fixer par la suite.
WICHTIG: Der Endwinkel muss unbedingt in diesem Augenblick befestigen, es wird ganz nicht möglich später sein.
WARNING: The stop must be set at this moment because it will not be possible later.
IMPORTANTE: Si no se ha montado el tope ahora, será imposible colocarlo luego

1.

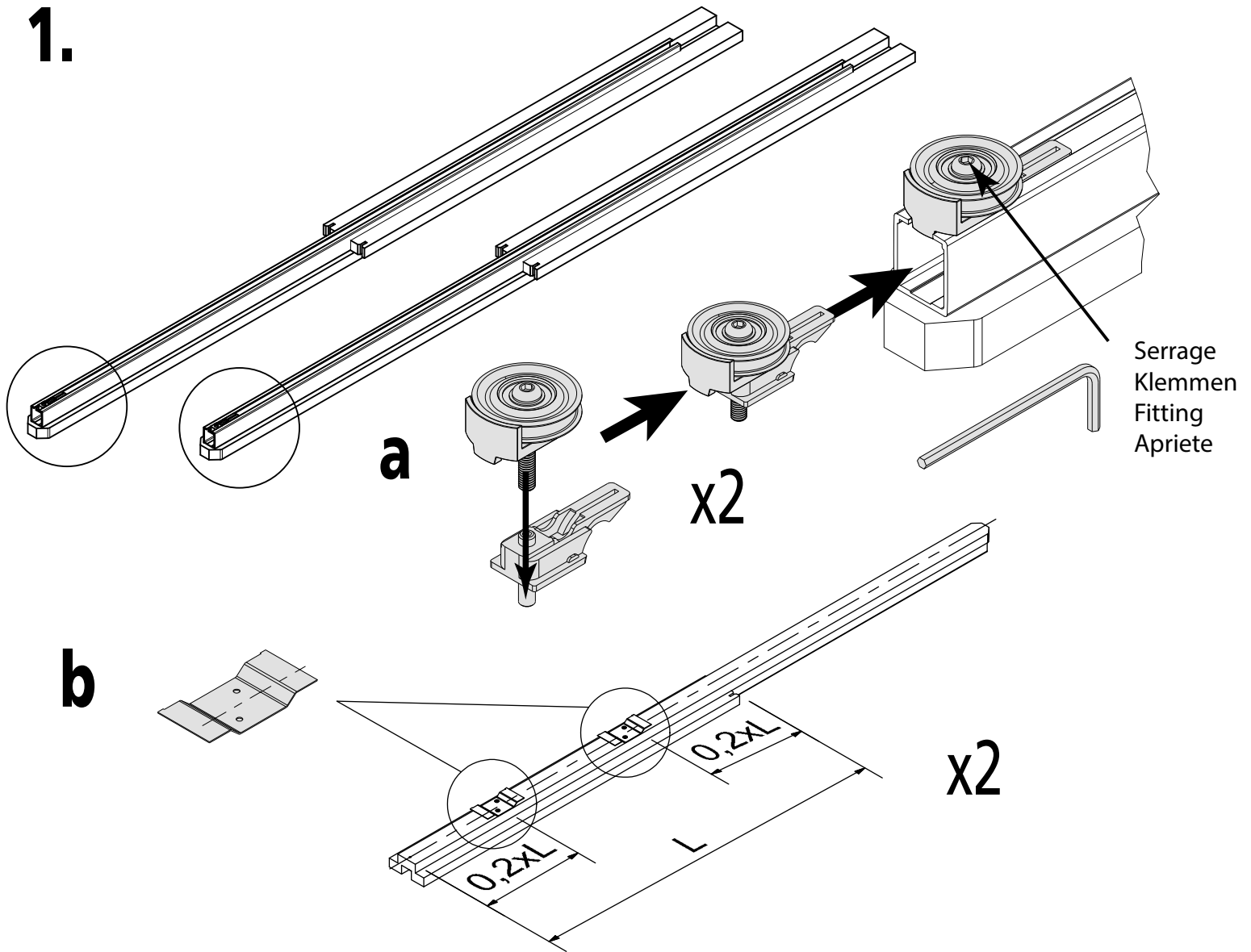

2.

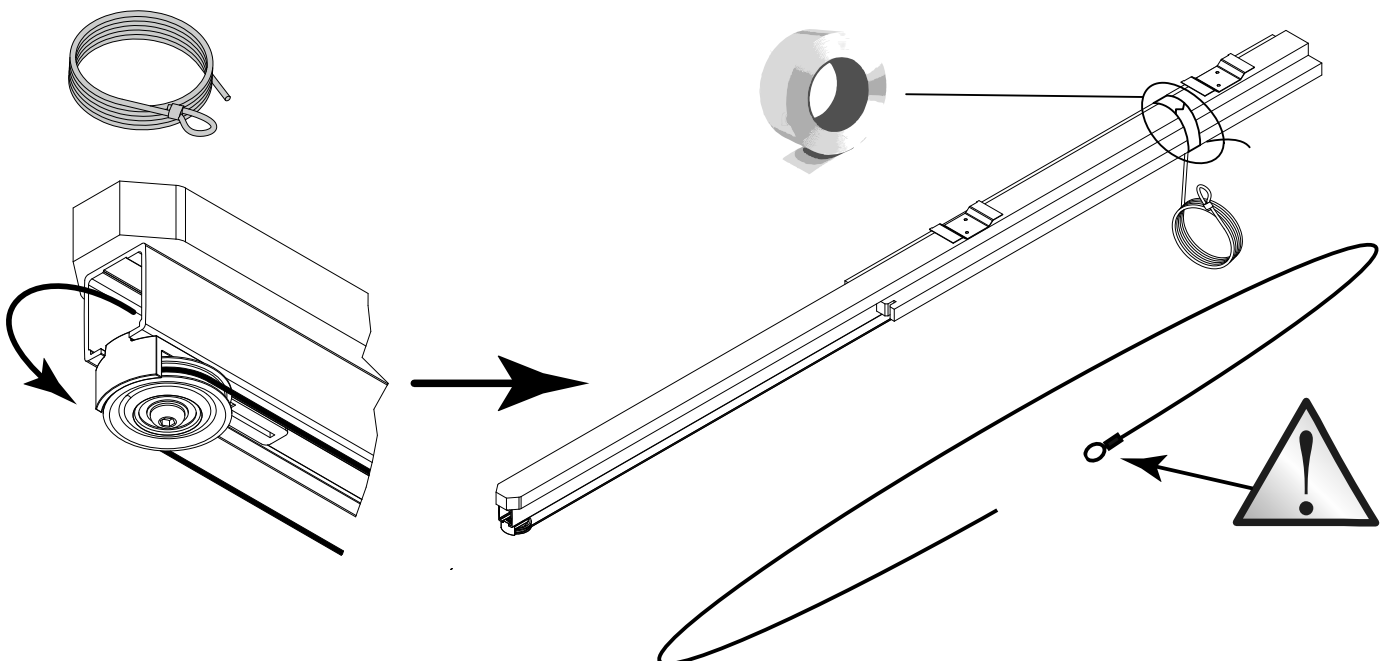

3.

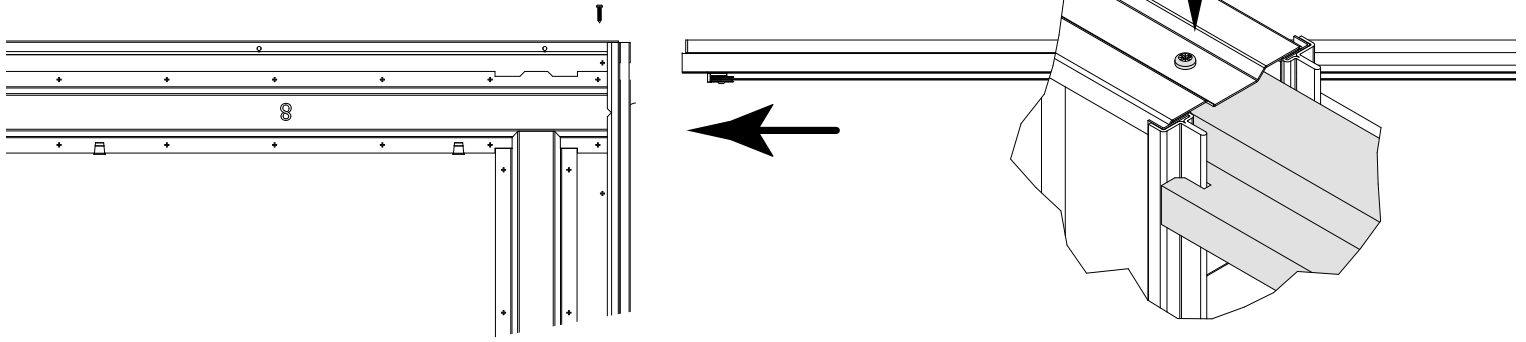

4.

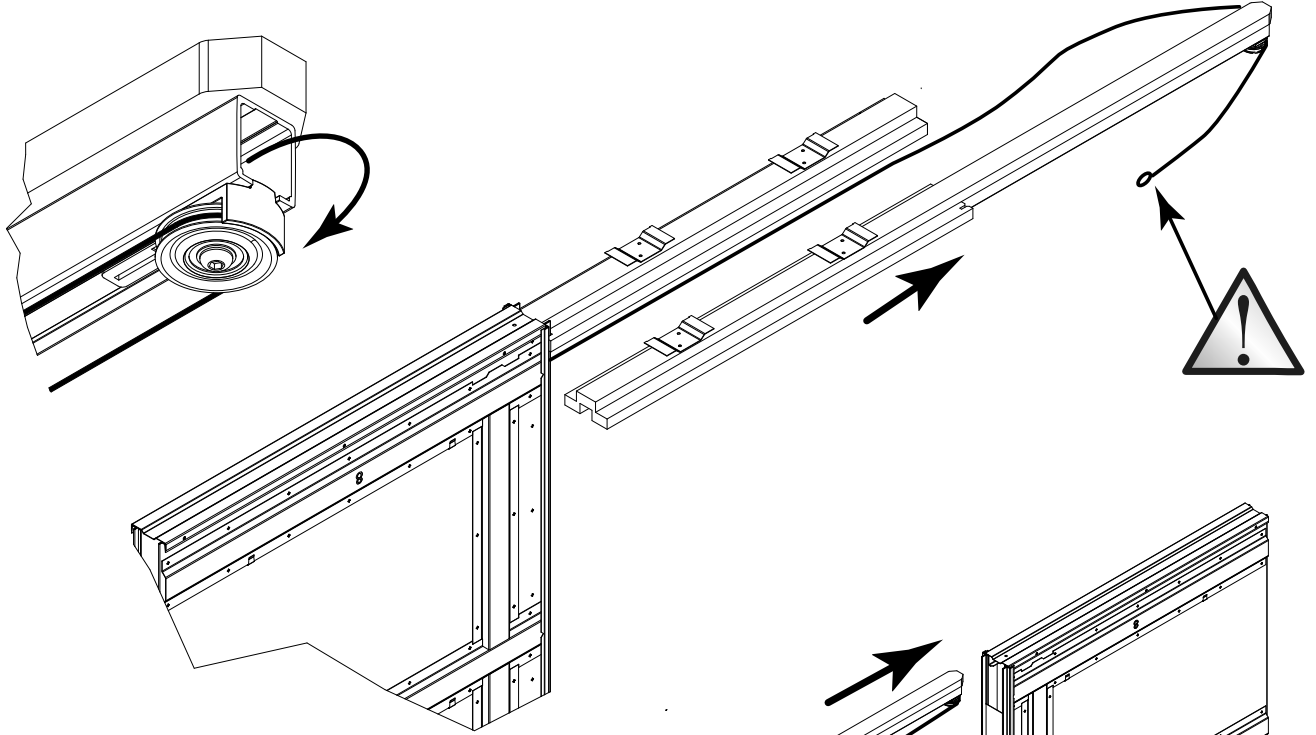

5.

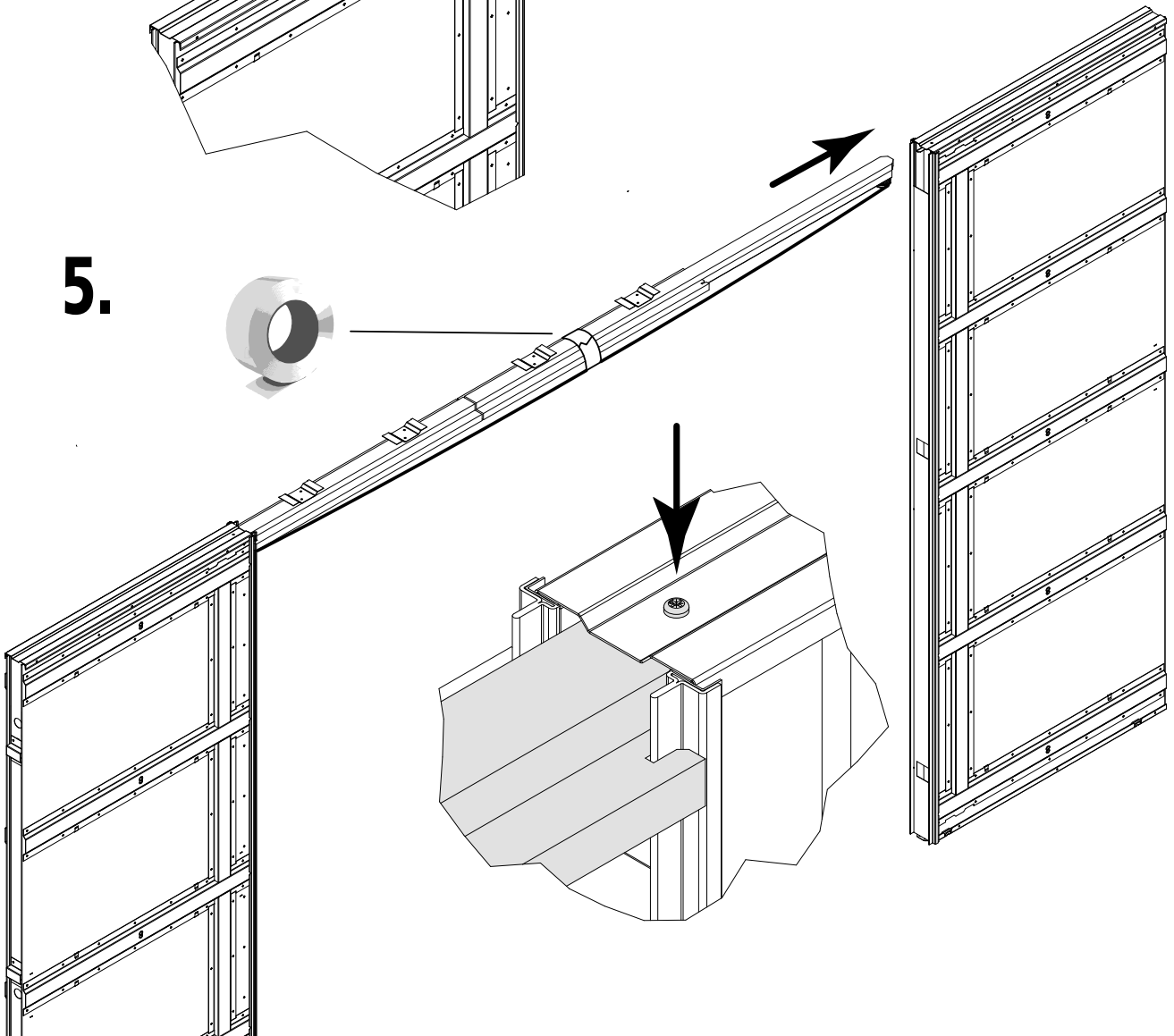

6.

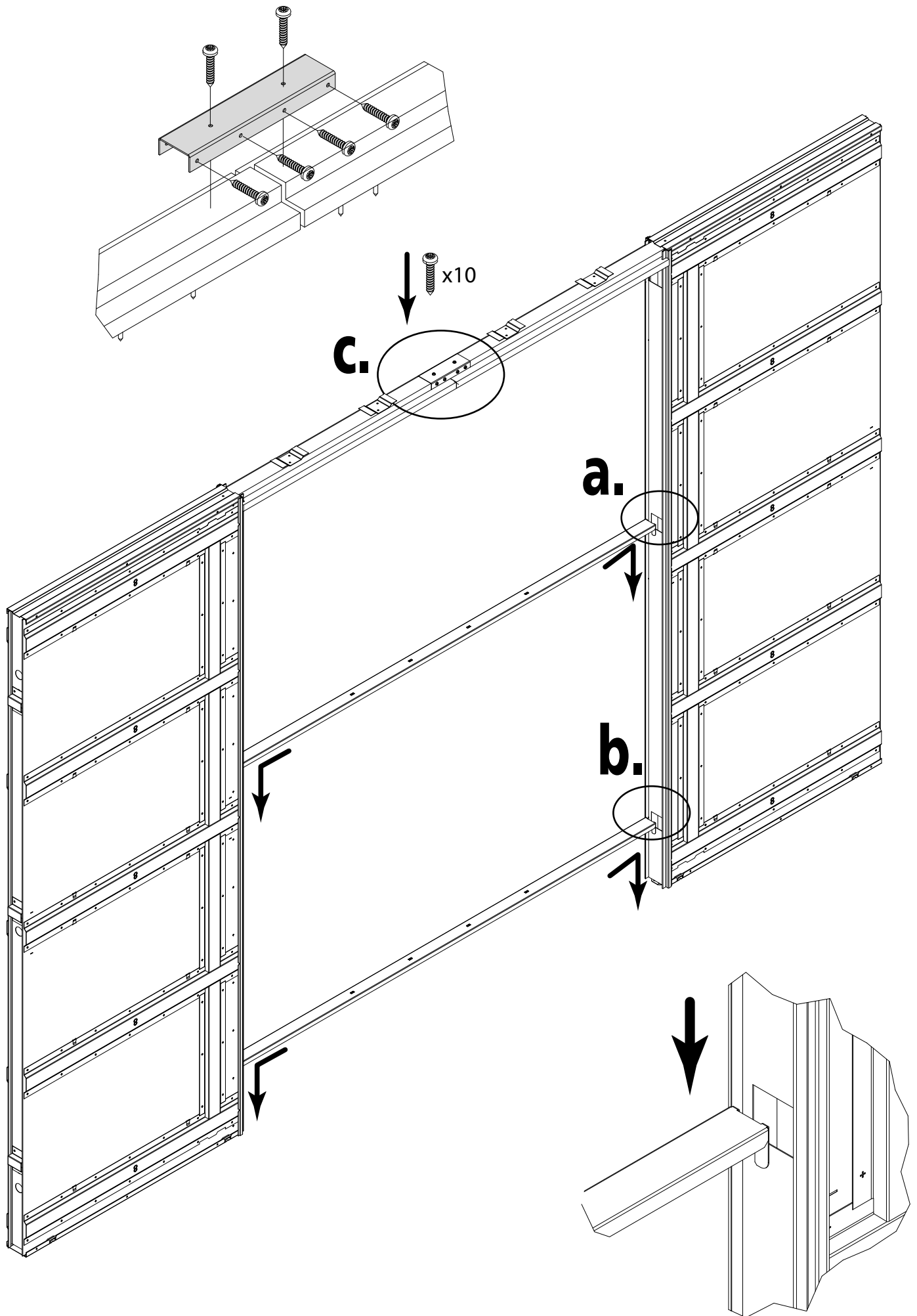

7.

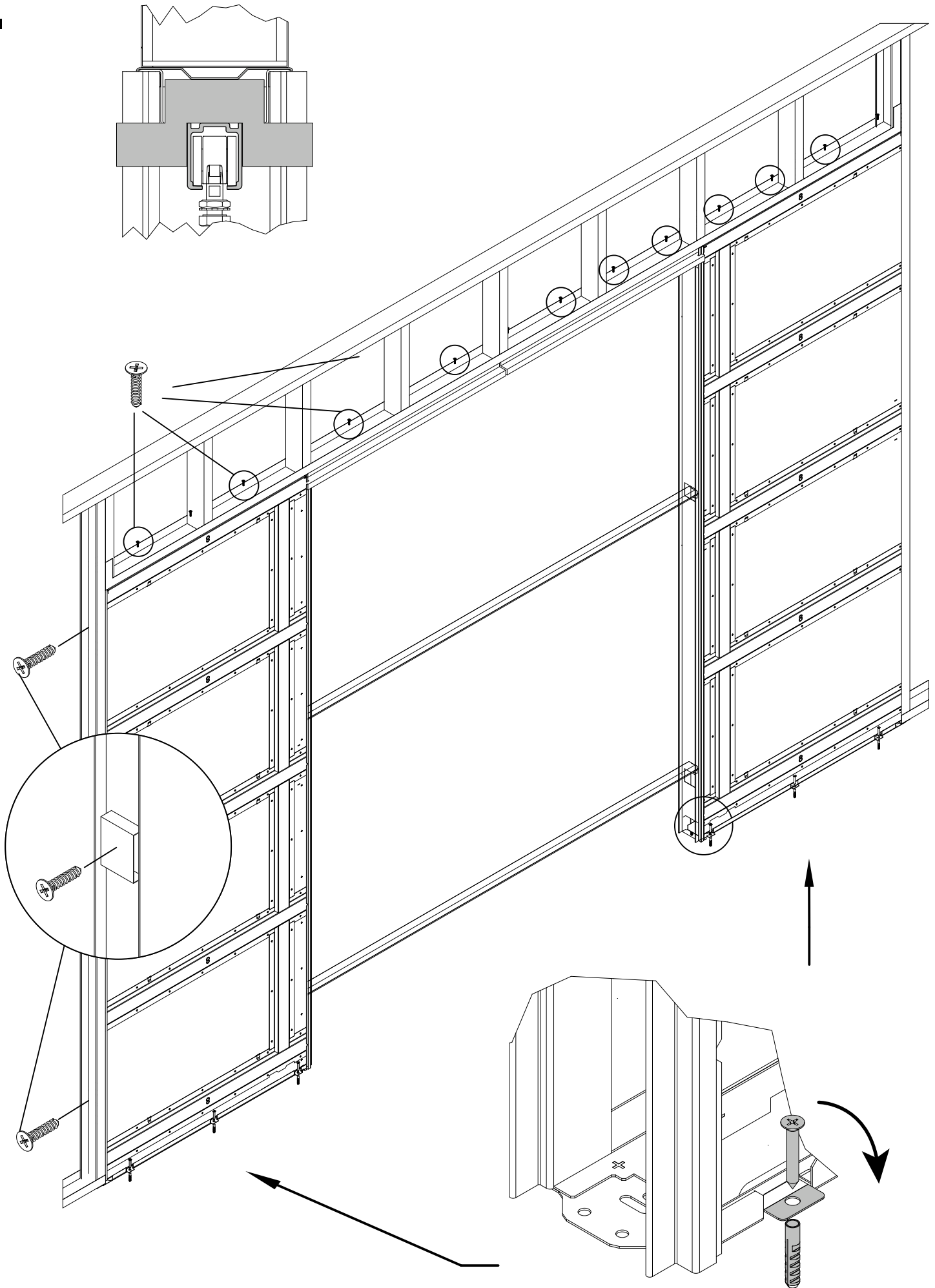

8.

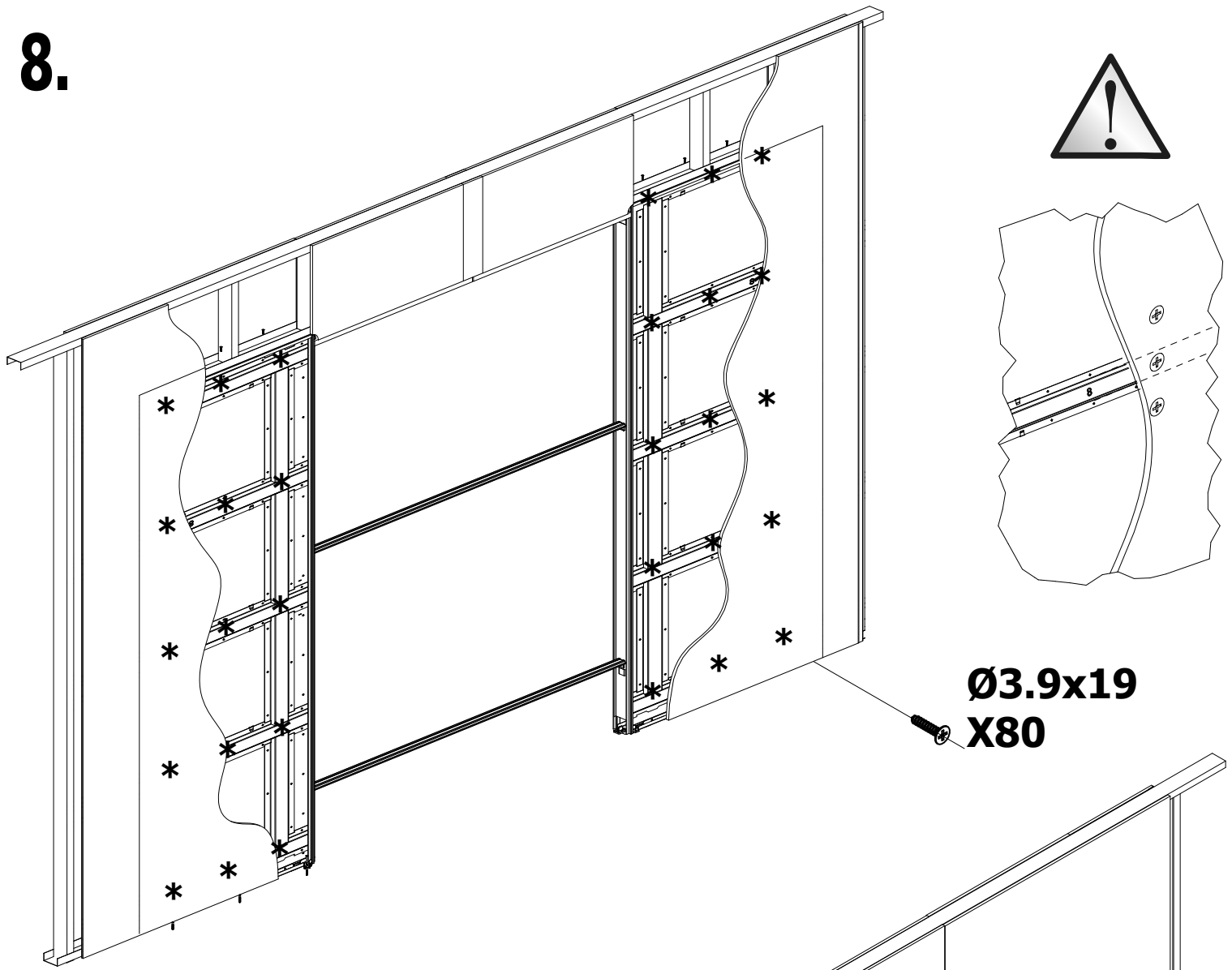

Ø3.9x19
X80

9.



retirer l'intégralité des cales en polystyrène

Die ganze Polystyrolsklotze entfernen

Remove completely the polystyrene's chock

Eliminar completamente la cuña de poliestireno

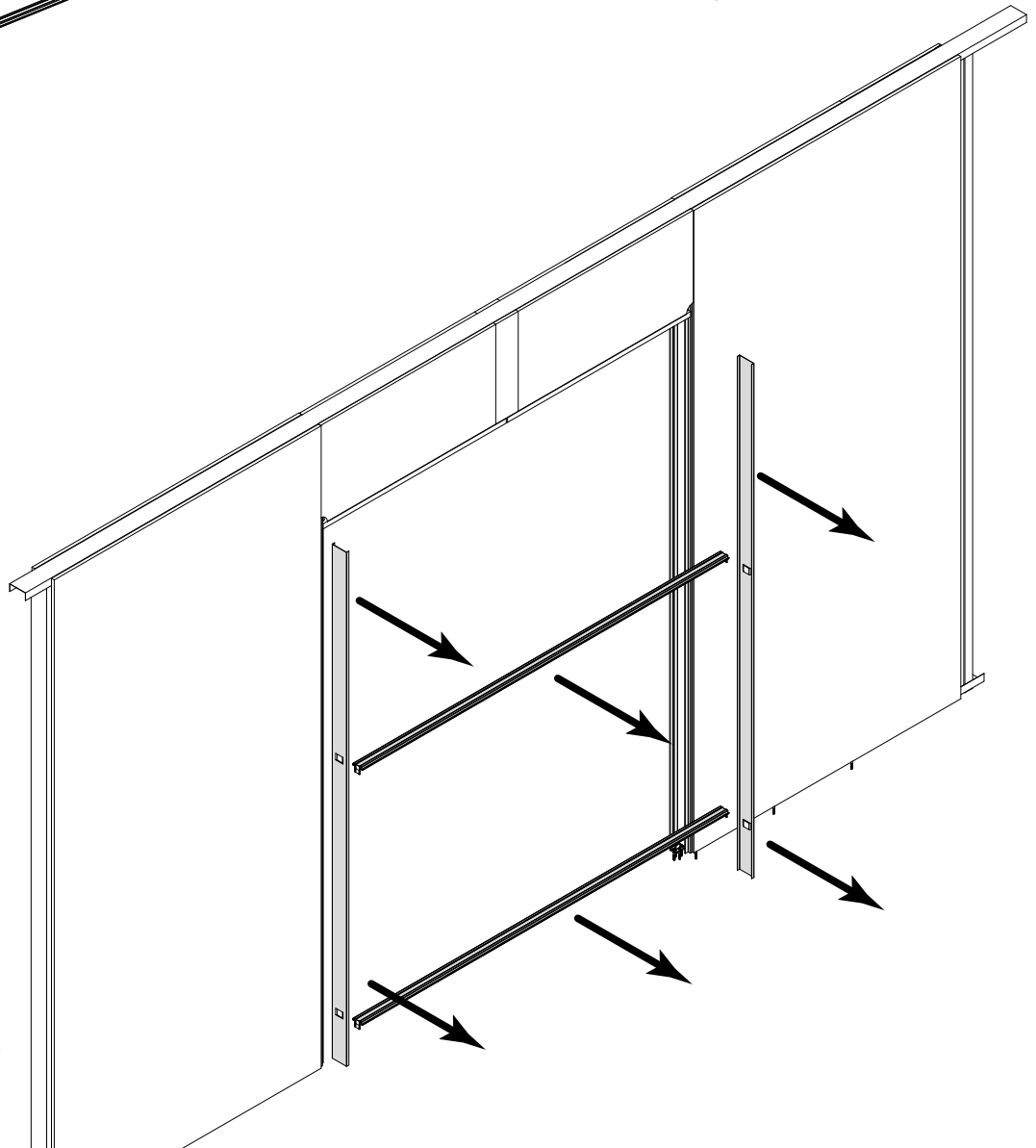

10.

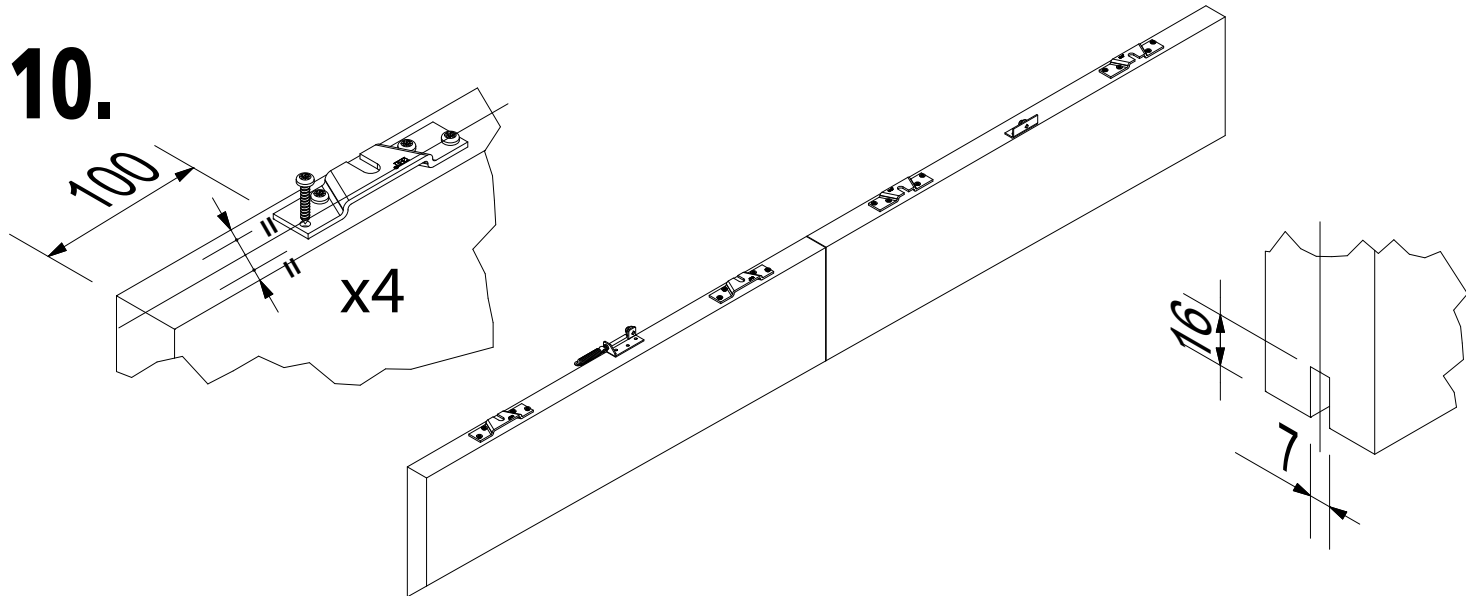

11.

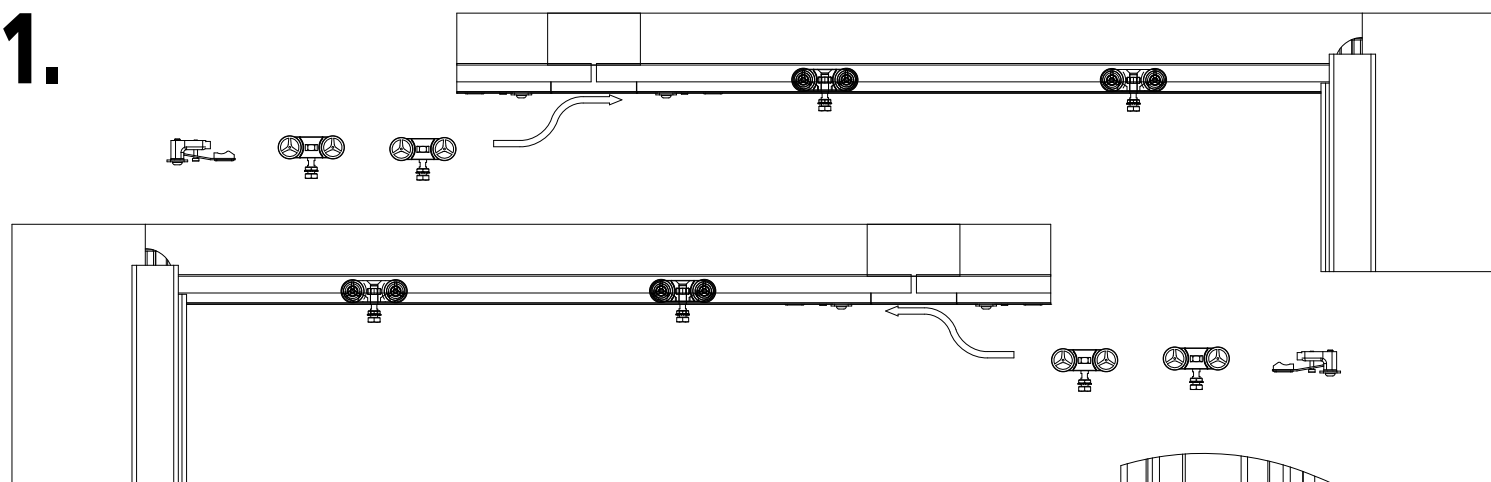

12.

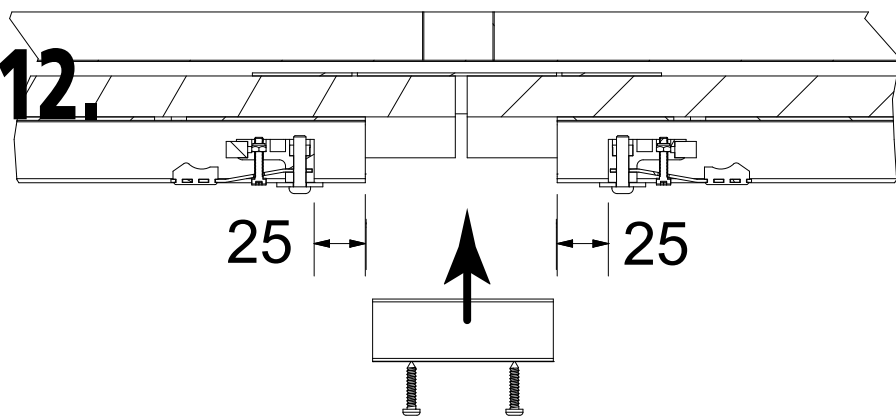

13.

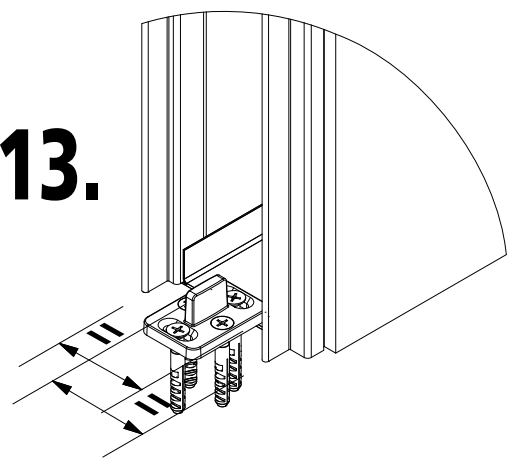

14.

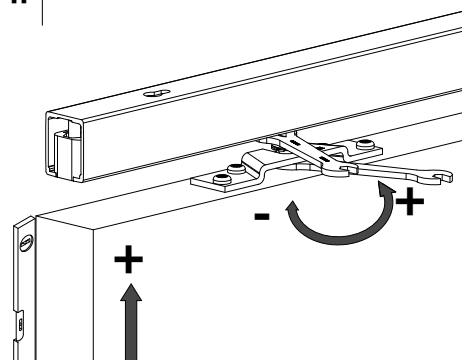
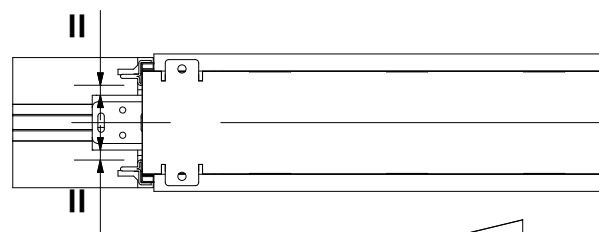
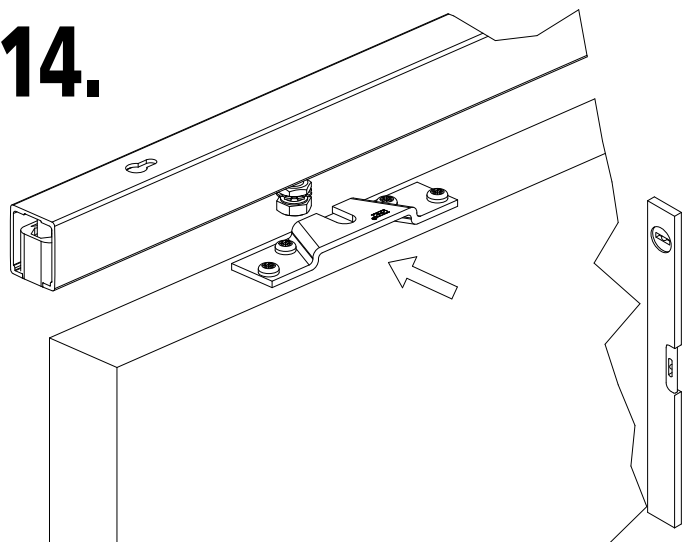

15.

a.1

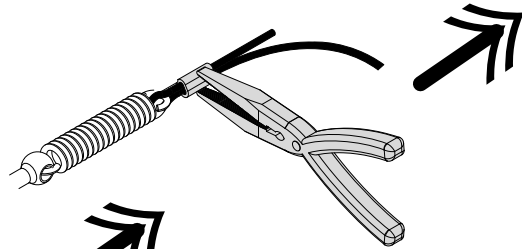
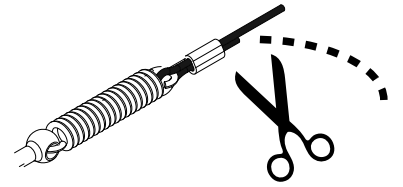
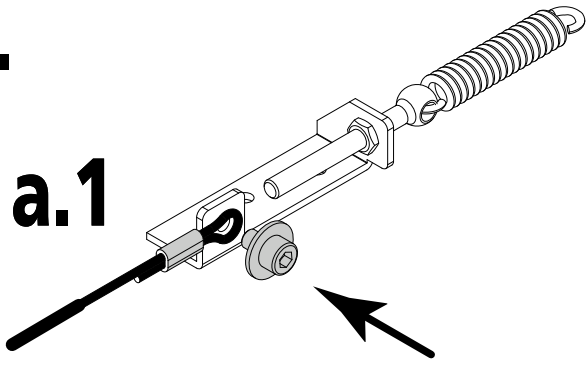

a.2

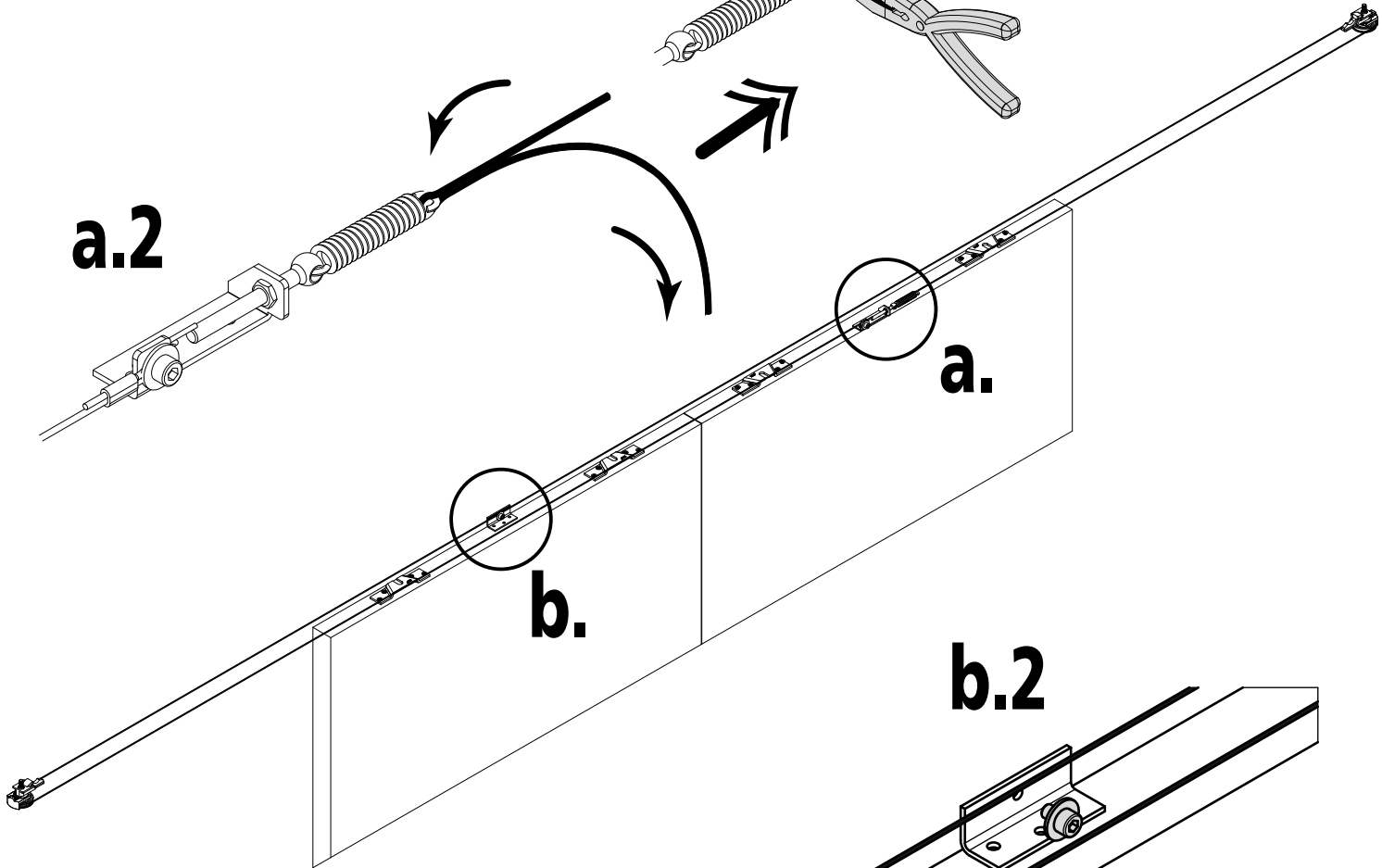
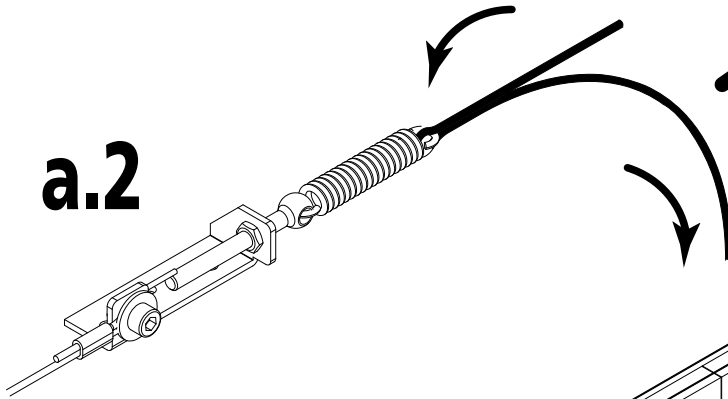

b.2

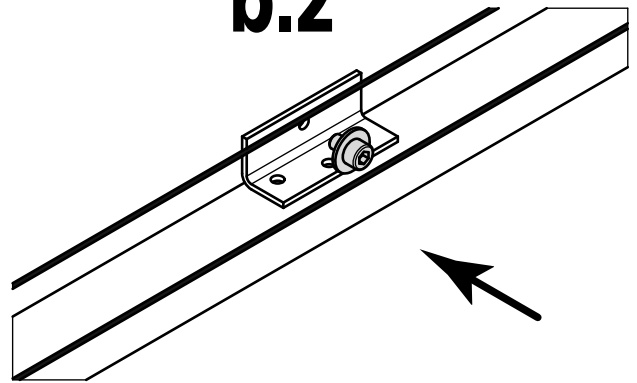

b.1

