

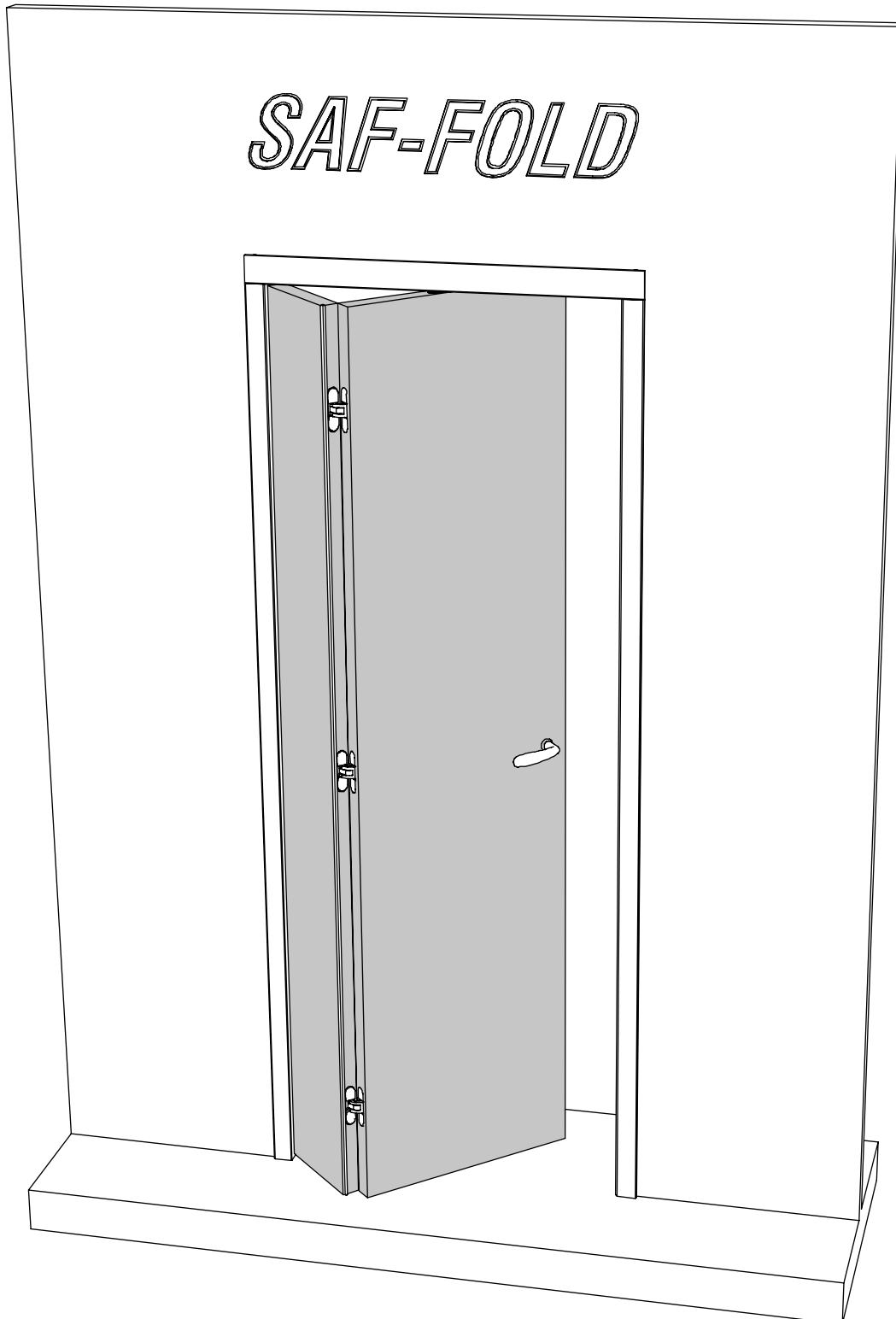

NOTICE DE MONTAGE  
MONTAGEANLEITUNG  
INSTRUCTIONS FOR ASSEMBLY  
INSTRUCCIONES DE MONTAJE

**SAF<sup>®</sup>-FOLD**

SFOLD80-1

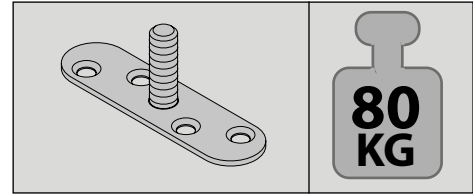

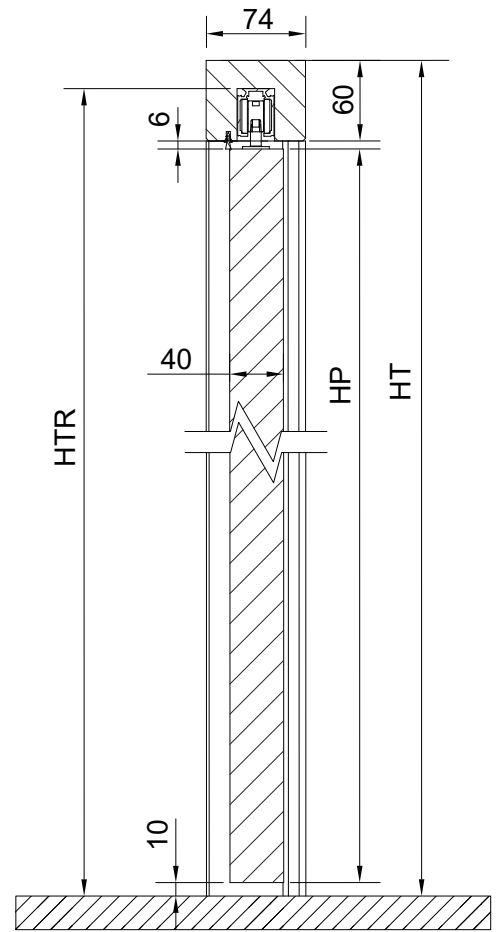
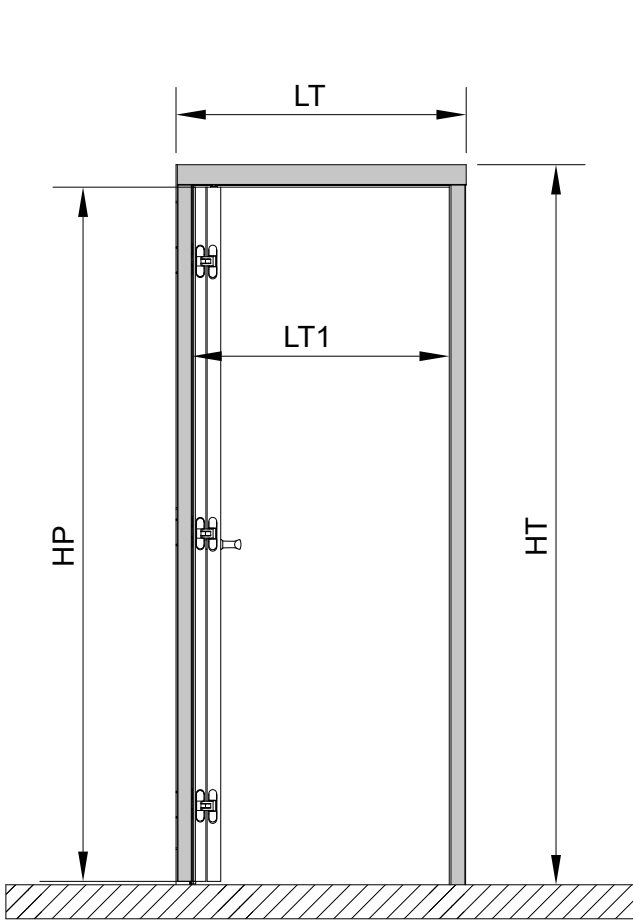

OPTION :

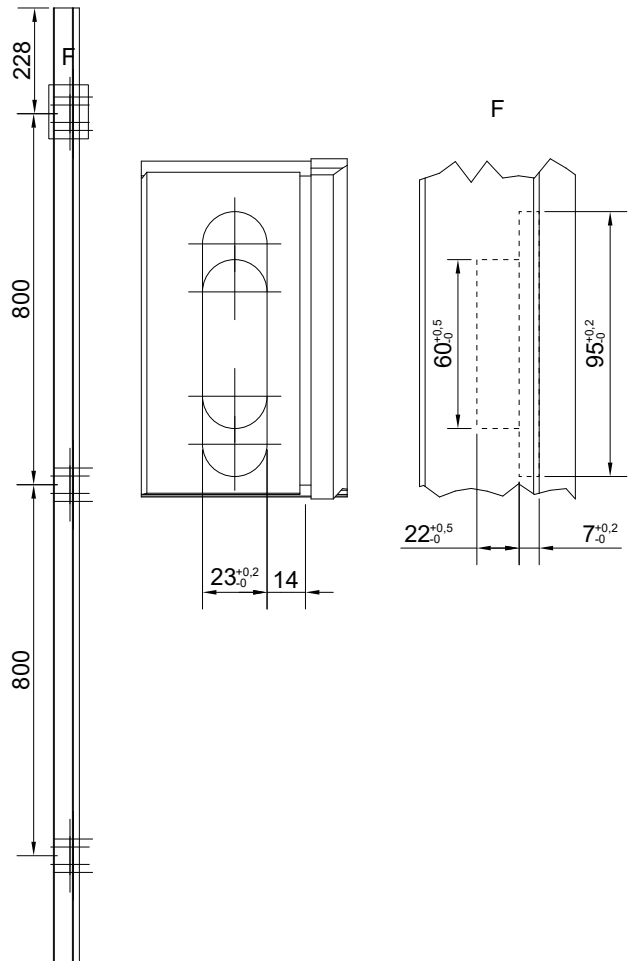
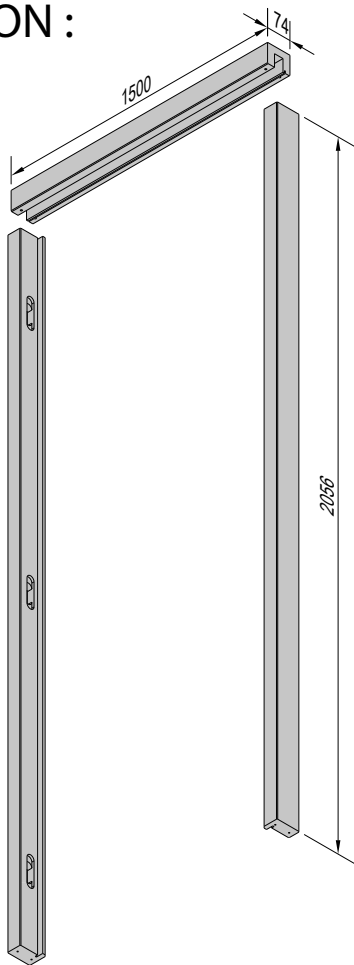

# USINAGE DES PANNEAUX MACHINING OF THE PANELS

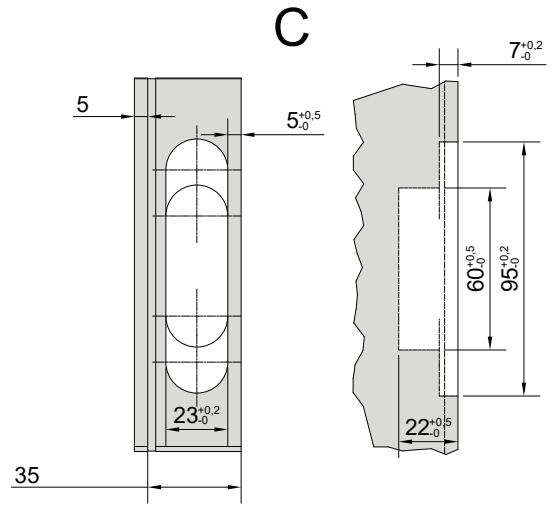
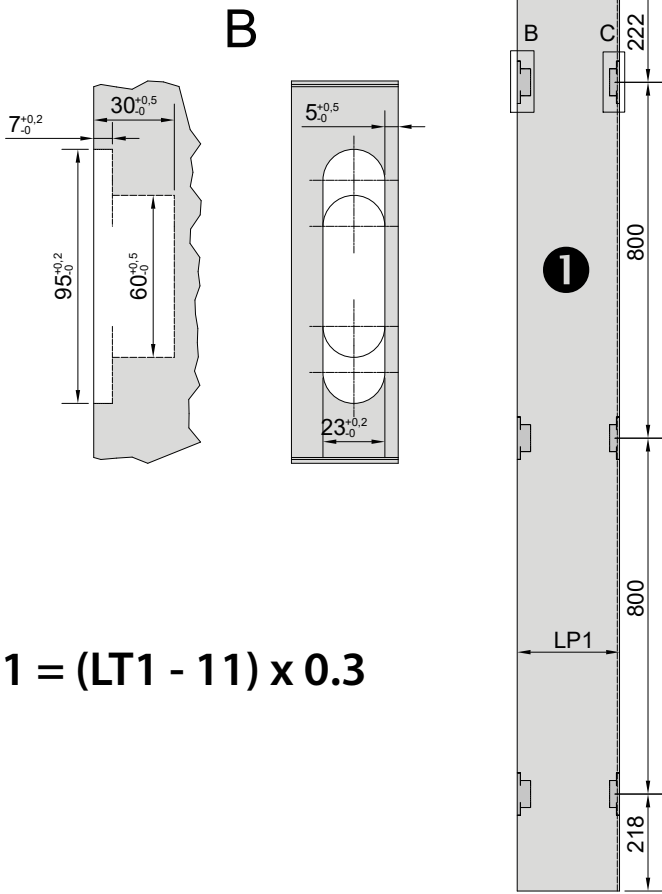

$$Lp1 = (LT1 - 11) \times 0.3$$

OPTION :

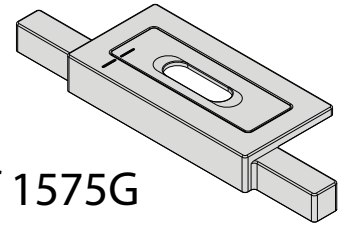

Ref 1575G

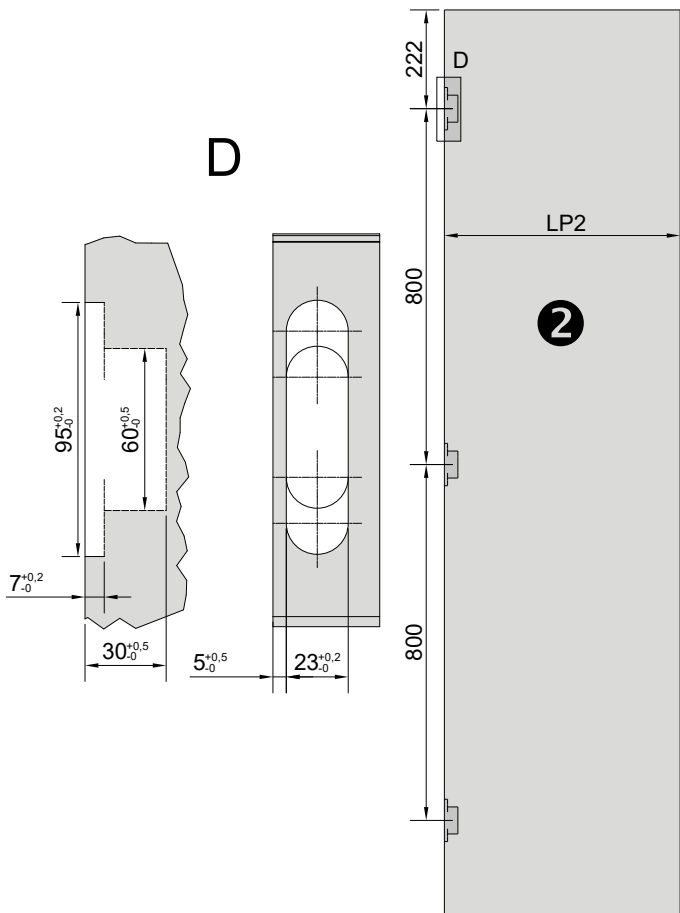

$$Lp2 = (LT1 - 11) \times 0.7$$

# MONTAGE / ASSEMBLY

