



NOTICE DE MONTAGE
MONTAGEANLEITUNG
INSTRUCTIONS FOR ASSEMBLY
INSTRUCCIONES DE MONTAJE

NM OPENTEC FW75



SYSTÈME COULISSANT PLIANT POUR PANNEAUX BOIS FALTSYSTEME FÜR HOLZPANELEE SLIDING/FOLDING SYSTEM FOR WOODEN PANELS SISTEMA PARA PUERTA PLEGABLE CON PANELES DE MADERA

Poids maximal / vantail Maximales Gewicht / Türpaneele Maximum weight / panel Peso máximo / hoja	75 KG 165 lbs.
Epaisseur des vantaux* Ladendicke* Panels thickness* Espesor de las contraventanas*	30 --> 50 mm 1 1/8" --> 2"
Largeur des vantaux Flügelbreite Panel width Ancho de panel	400 --> 1000 mm 1 ft 3 3/4" --> 3 ft 3 3/8"
Nombre de vantaux Ladenanzahl Number of panels Numero de hojas agrupadas	6 + 6 12000 x 4000 mm 39 ft 4" - 13 ft 1"

SLIDSOFT®

Logiciel de calcul
(quantitatif, dimensionnement ...)

Computation software
(quantitative, sizing...)

Berechnungsprogramm
(quantitativ, Größenbestimmung...)

www.mantion.com

*Non fourni
*Nicht geliefert
*not supplied
*No suministrado

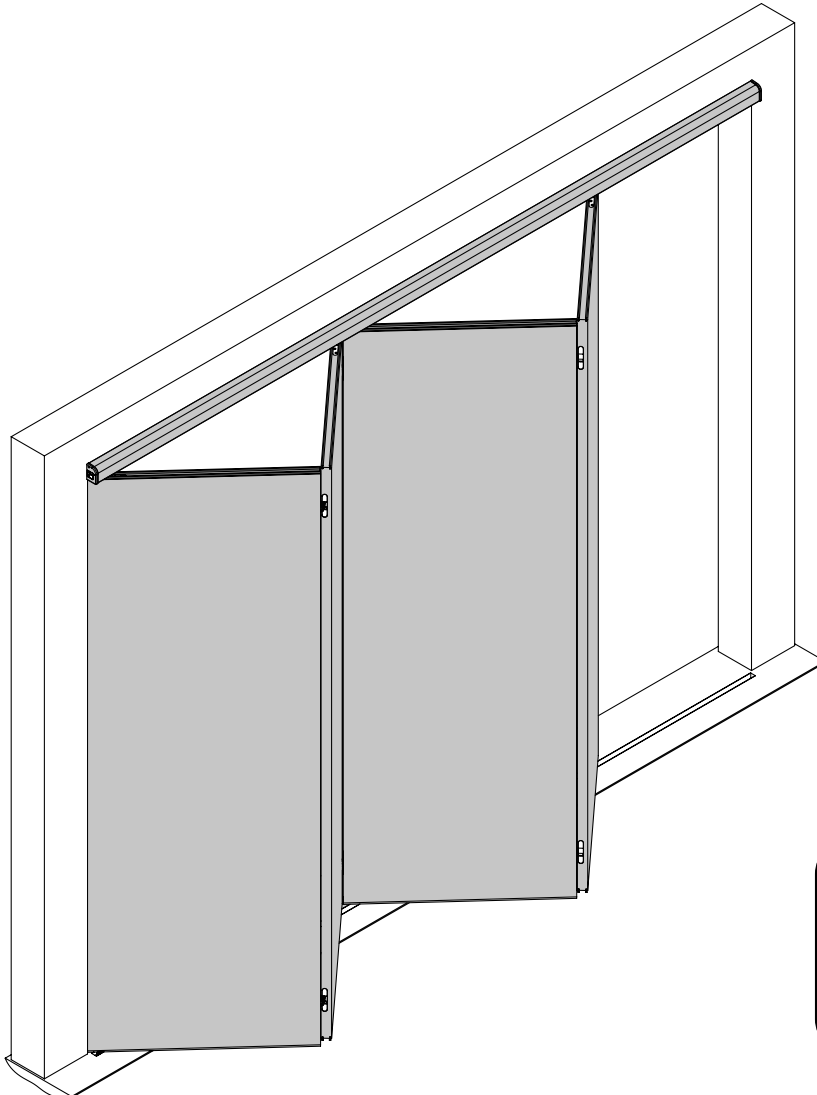

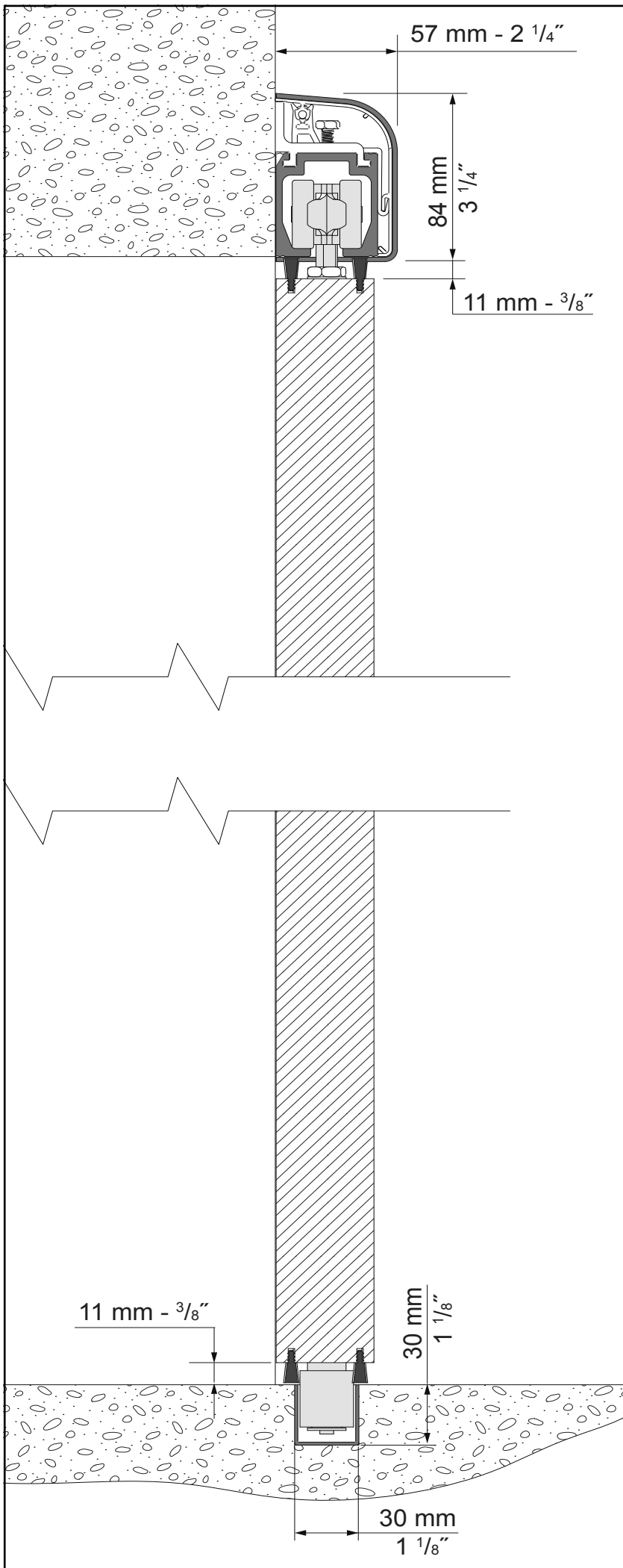

Montage plafond Ceiling mount

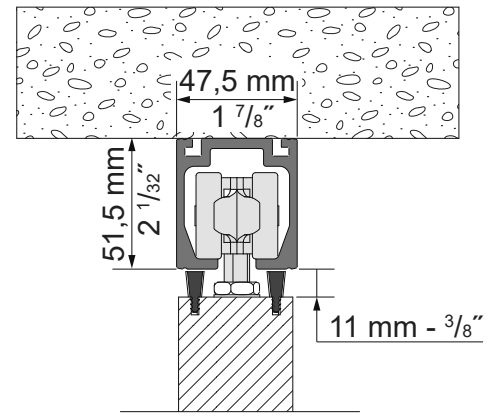

Montage intégré au plafond Recessed mounting in the ceiling

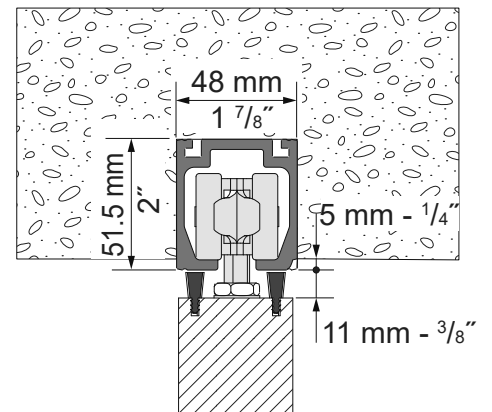

Pour détailler votre projet, c'est facile !
Il vous suffit de renseigner les dimensions de
votre baie et vos options.
Vous aurez aussi accès au détail complet des
produits et plans.

It is easy to determine the solution!
Simply enter the dimensions of your opening
and your options.
You will also have access to the full details
of the products and plans.

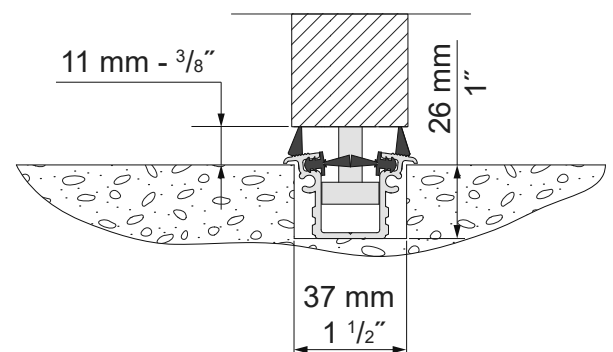

www.slidsoft.com

TOLÉRANCES DE LA BAIE - TOLERANCE OF THE BAY

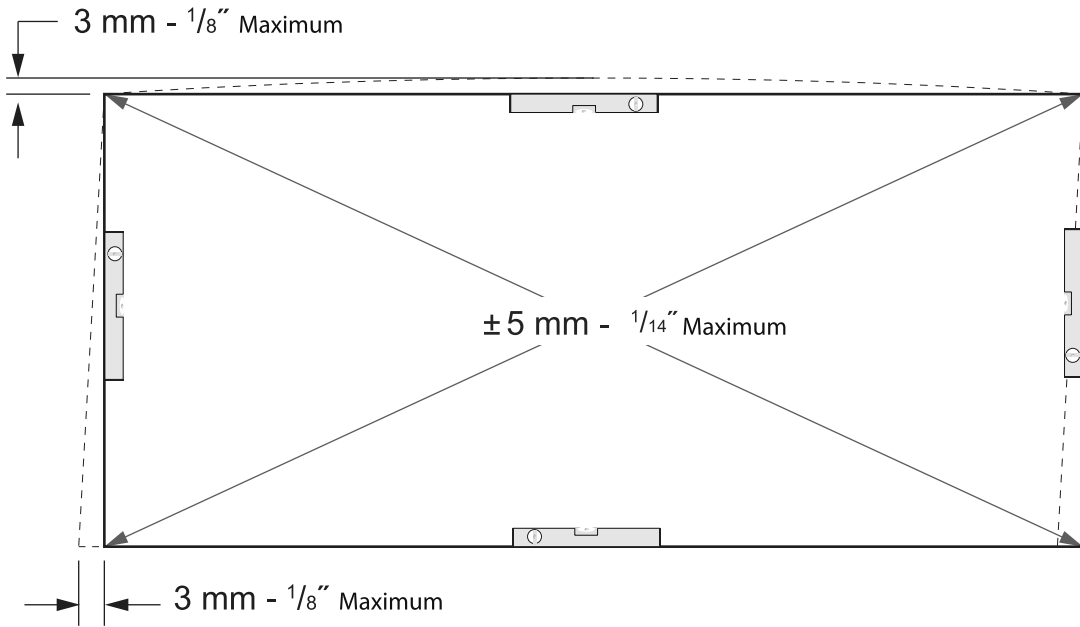

MAÇONNERIE - MASONRY

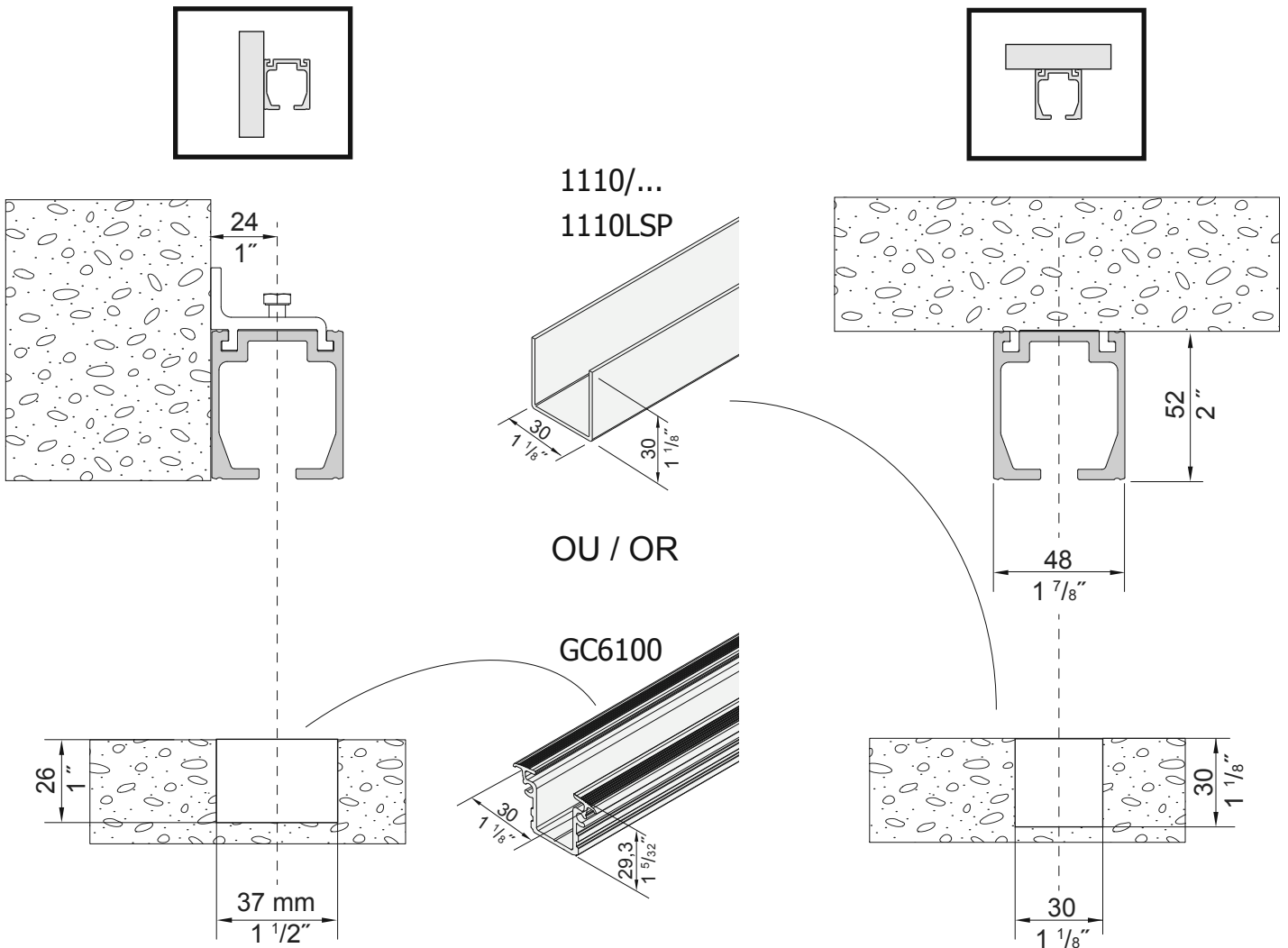

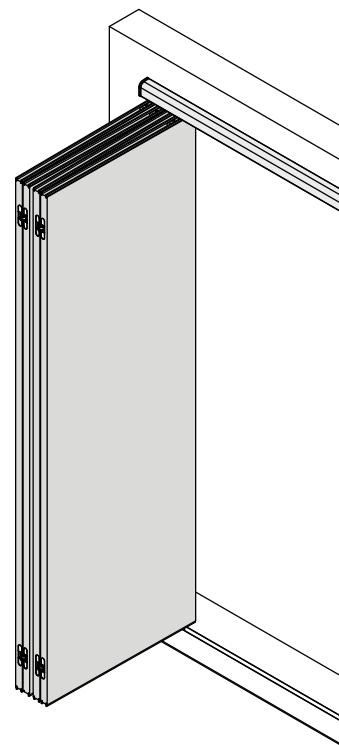
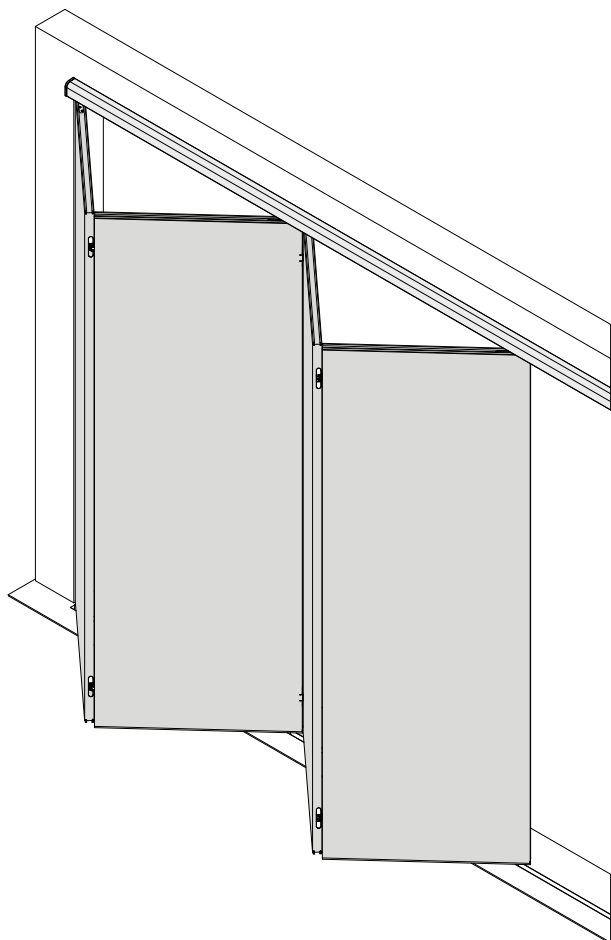
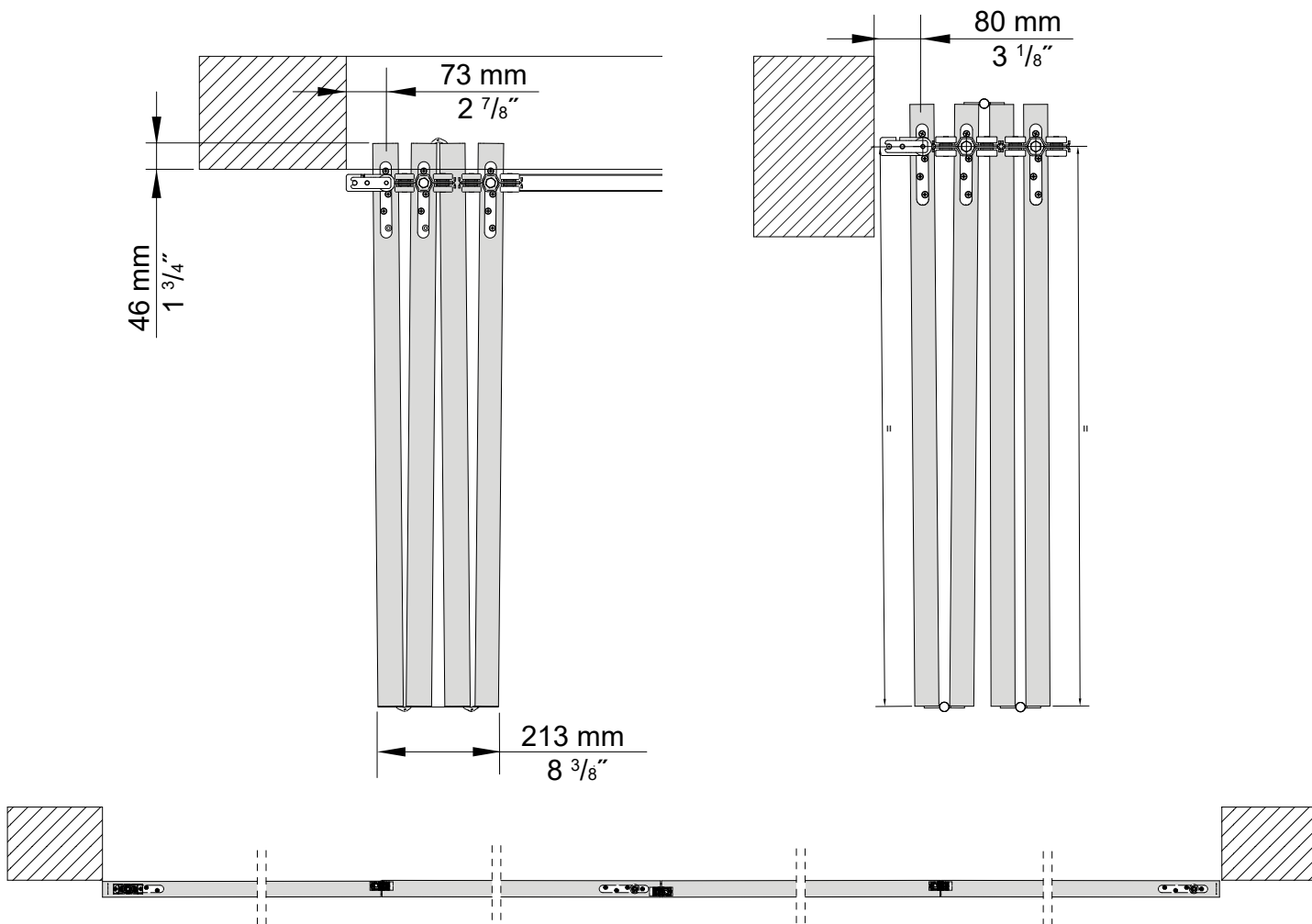

COMPOSITION - ZUSAMMENSETZUNG - COMPOSICIÓN



Non fourni - Nicht geliefert - not supplied - No suministrado

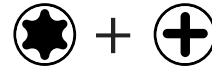
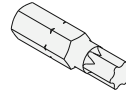
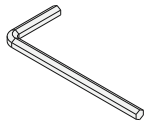

* OPTIONS

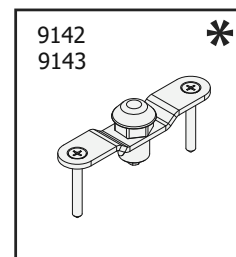
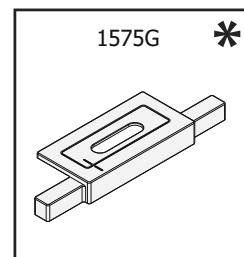
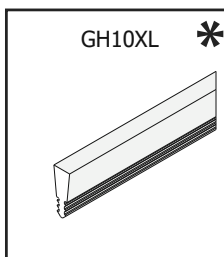
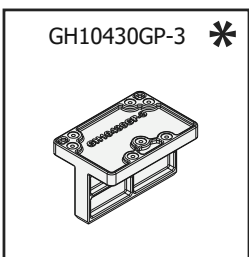
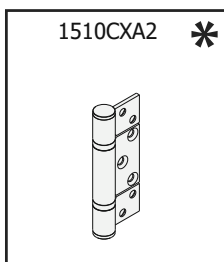
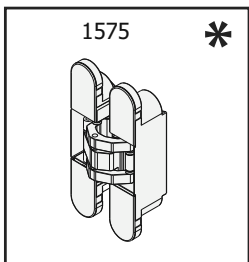
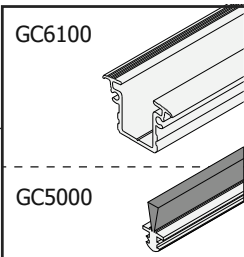
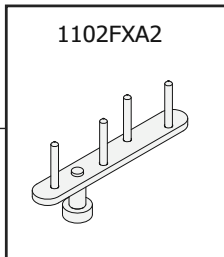
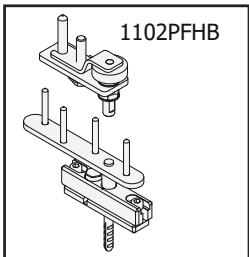
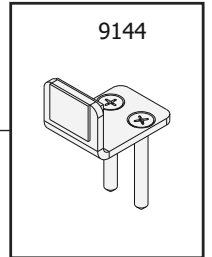
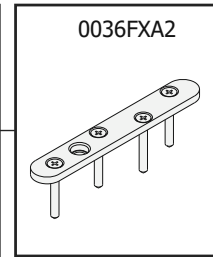
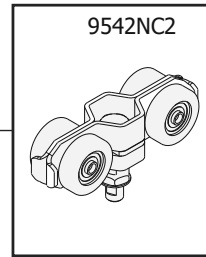
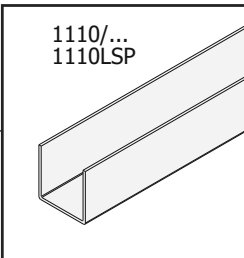
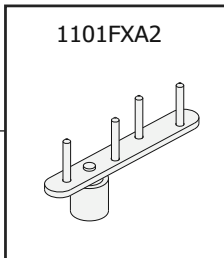
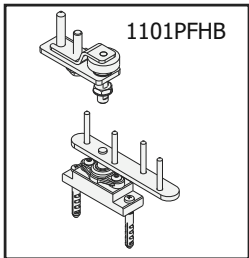
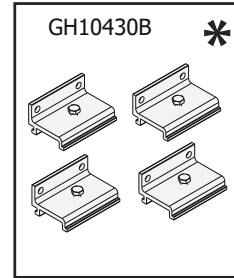
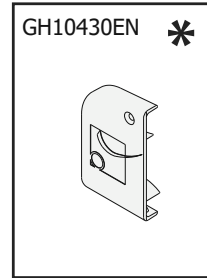
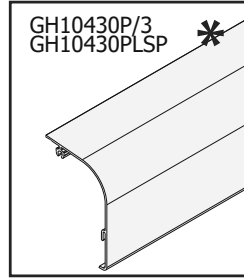
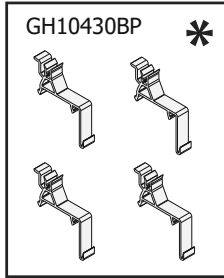
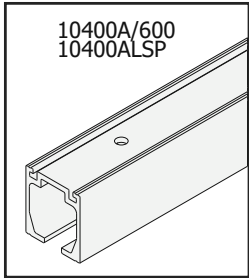

CHOIX DE LA CONFIGURATION CHOICE OF THE CONFIGURATION

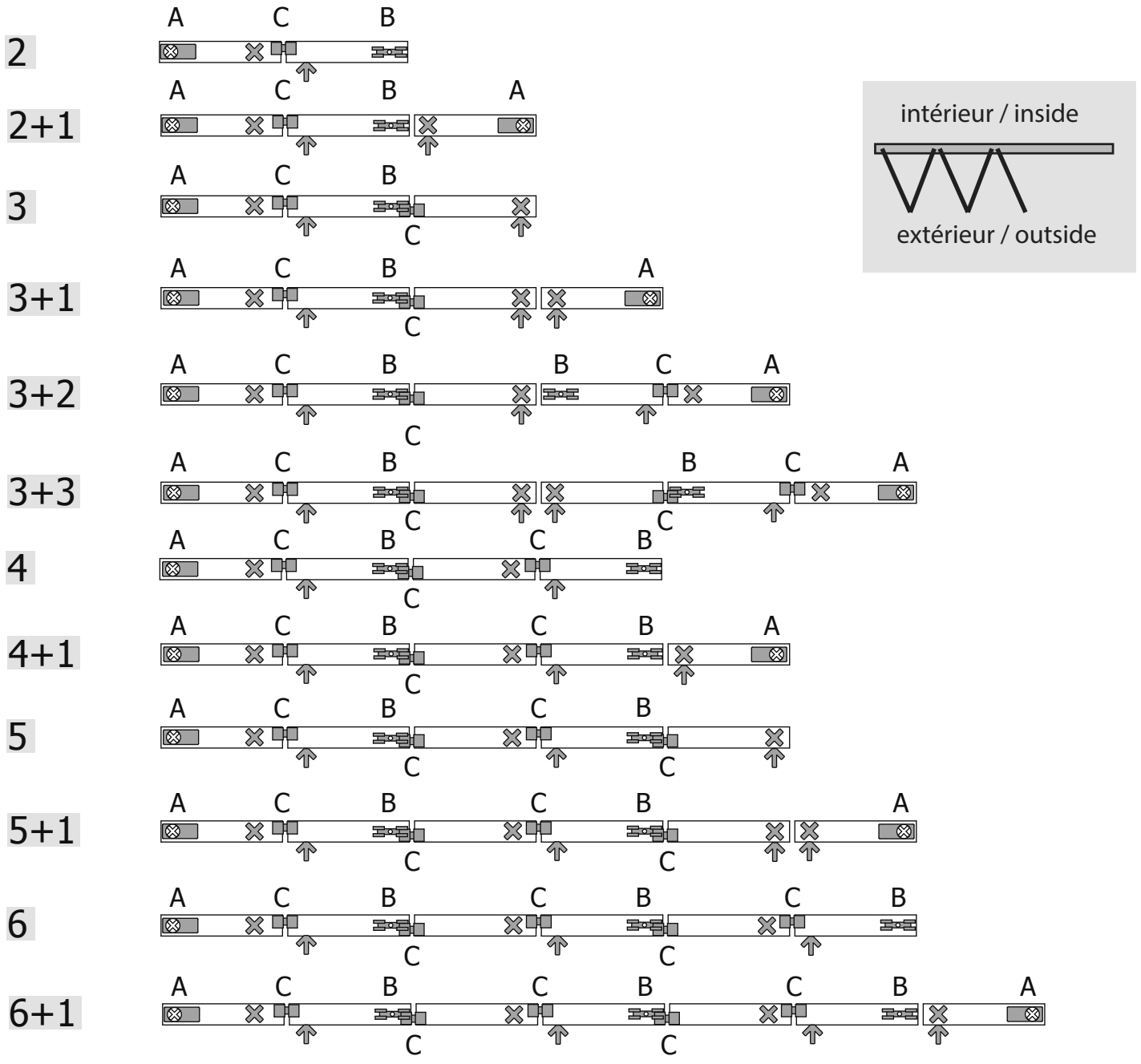

A B C D E

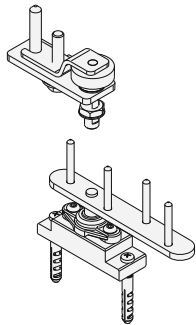

1101PFHB
1102PFHB

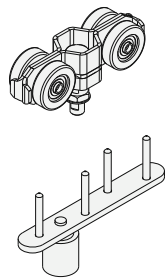

9542NC2
1101FXA2
1102FXA2

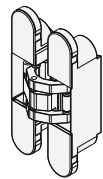

1575
1510CXA2

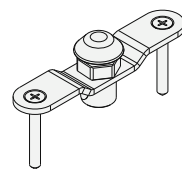

9142
9143

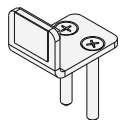

9144

CHOIX DE LA CONFIGURATION CHOICE OF THE CONFIGURATION

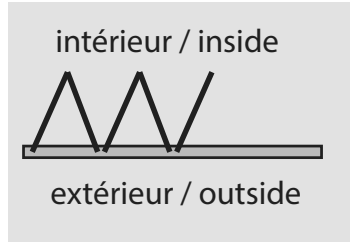
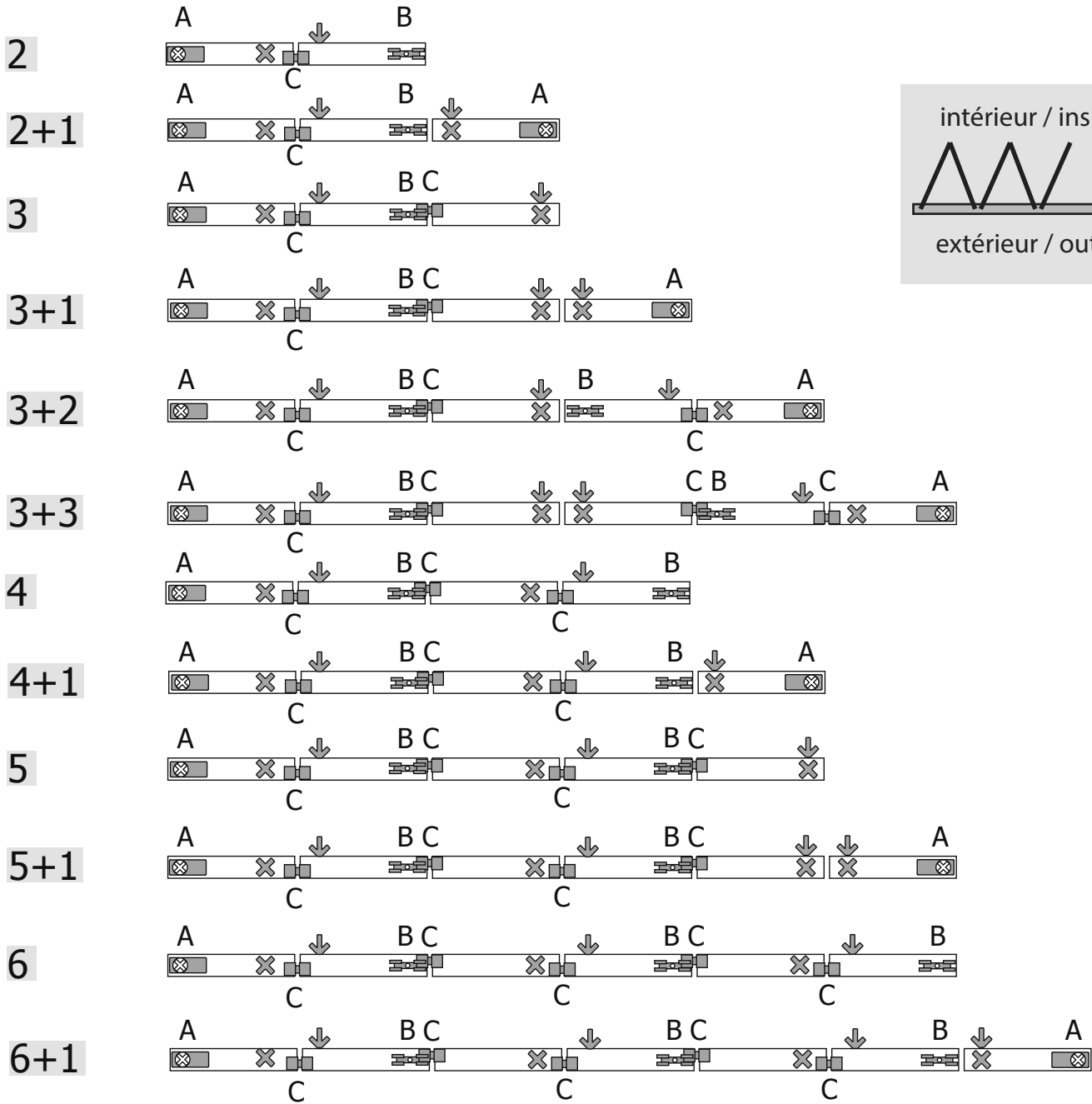

A  **B**  **C**  **D**  **E** 

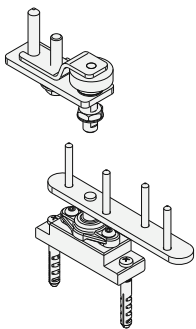

1101PFHB
1102PFHB

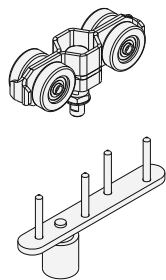

9542NC2
1101FXA2
1102FXA2

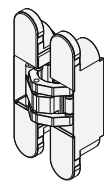

1575
1510CXA2

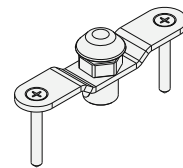

9142
9143

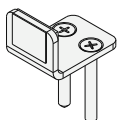

9144

USINAGE DES PANNEAUX MACHINING OF THE PANELS

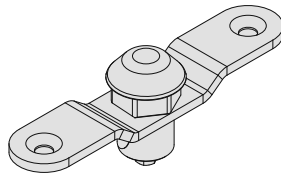
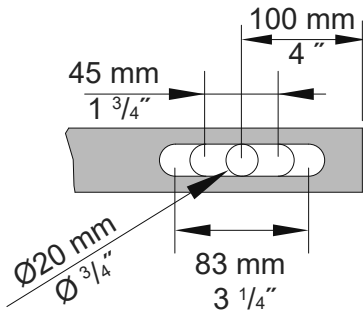

9142 / 9143
Tous les 2 panneaux
en partie haute
Every 2 panels
at the top

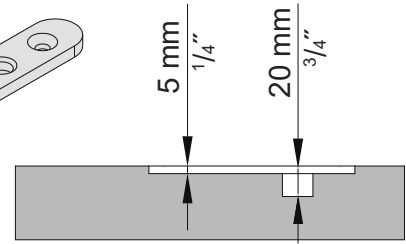
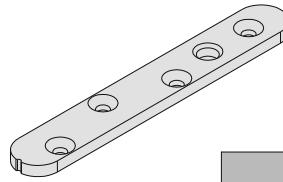
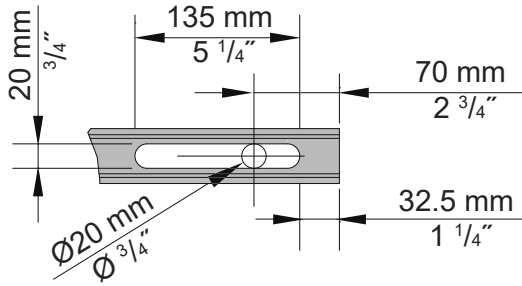
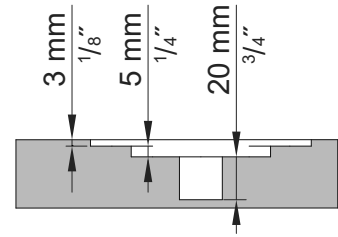

Rainure pour brosse
Groove for seal
GH10XL

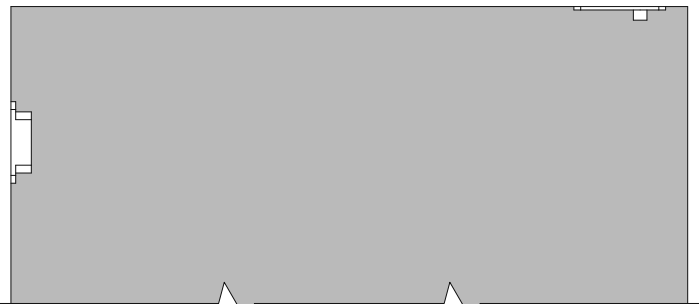
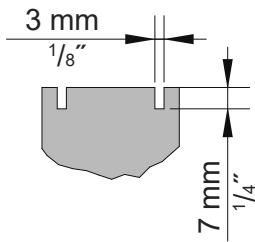

Charnières - Hinges
1575

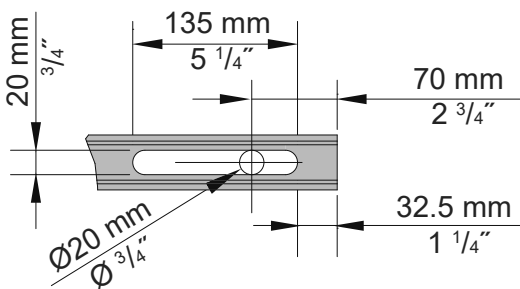
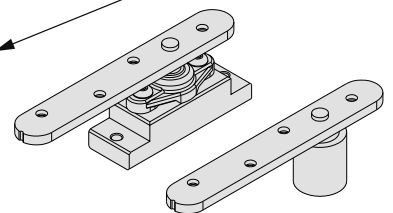
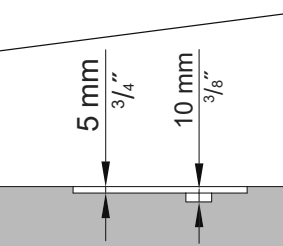
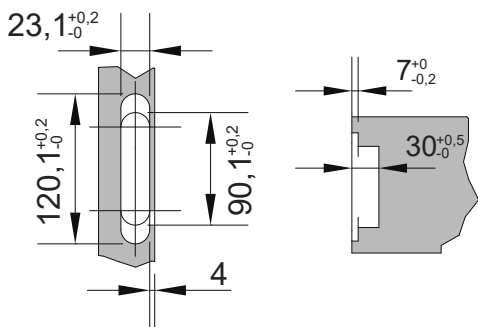

EQUIPEMENT DES PANNEAUX EQUIPMENT OF PANELS

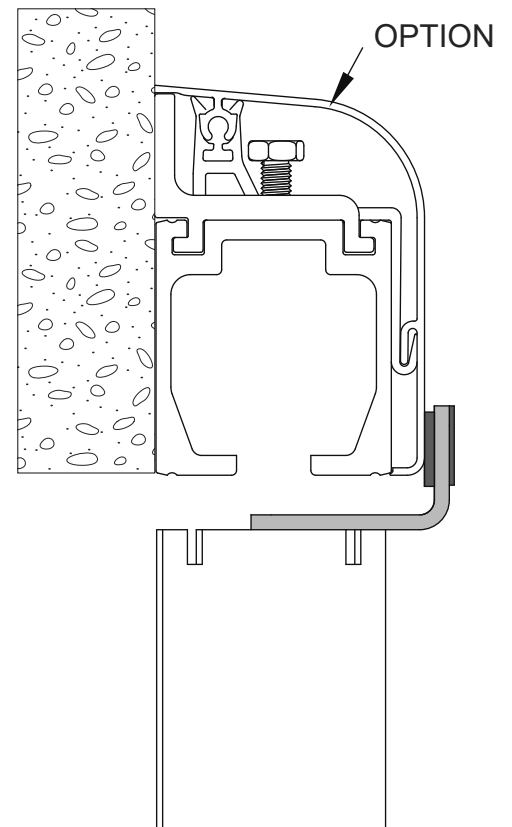
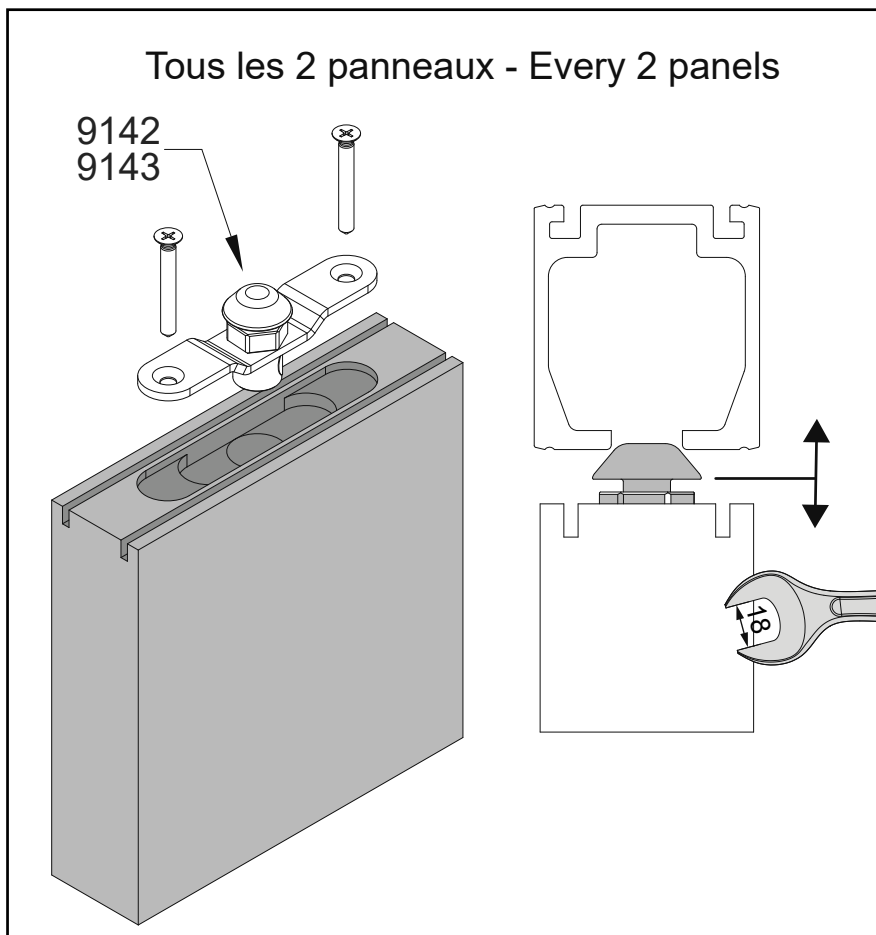
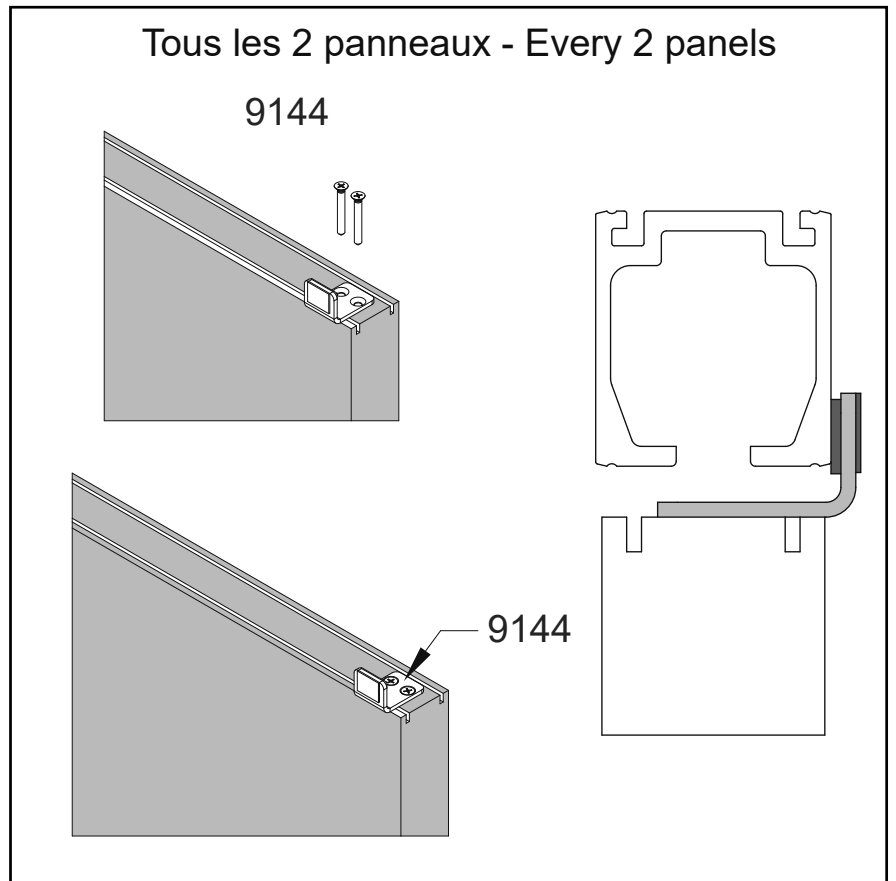
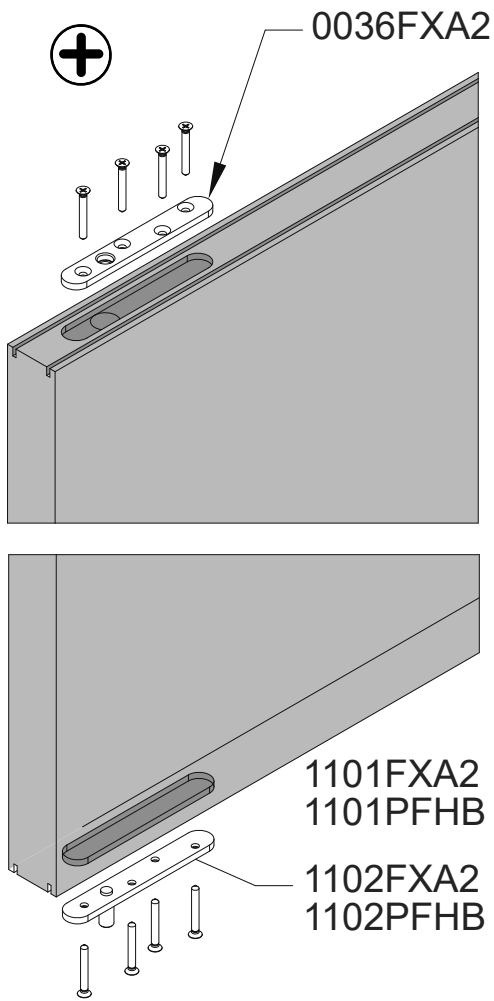

FIXATION DU RAIL HAUT FIXING OF THE UPPER TRACK

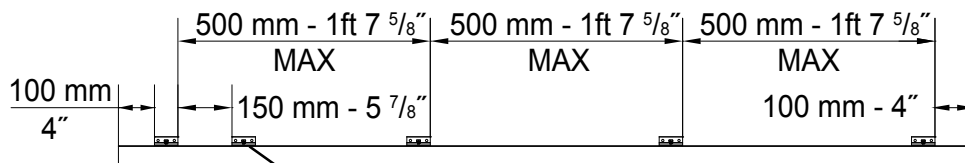
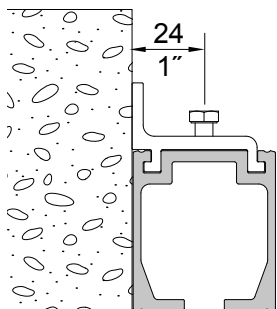
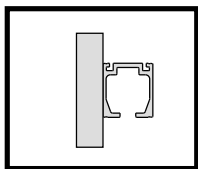

support supplémentaire dans la zone de stockage
 supplementary support on the pushback side
 Doppelte Trägeranzahl auf der Öffnungsseite anbringen

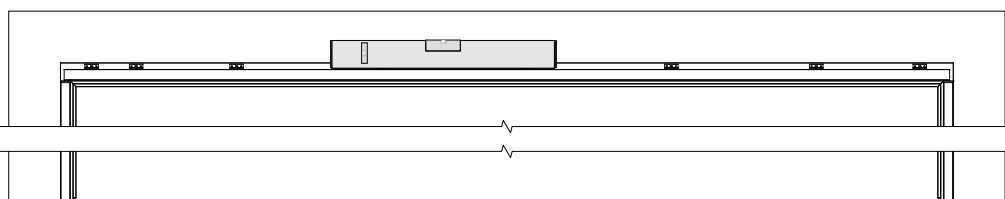
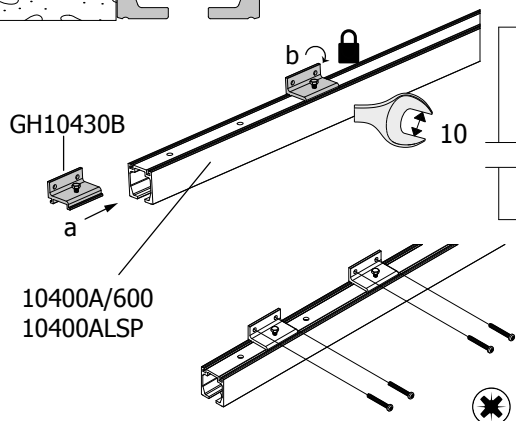

**il est recommandé de bien nettoyer
 l'intérieur des profils**
**it is recommended that the inside of the
 tracks be correctly cleaned**
**die Innenseiten der Profi le
 gut zu reinigen**

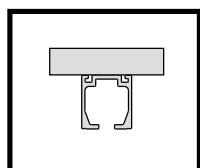

**ZONE DE STOCKAGE
 PUSHBACK SIDE**

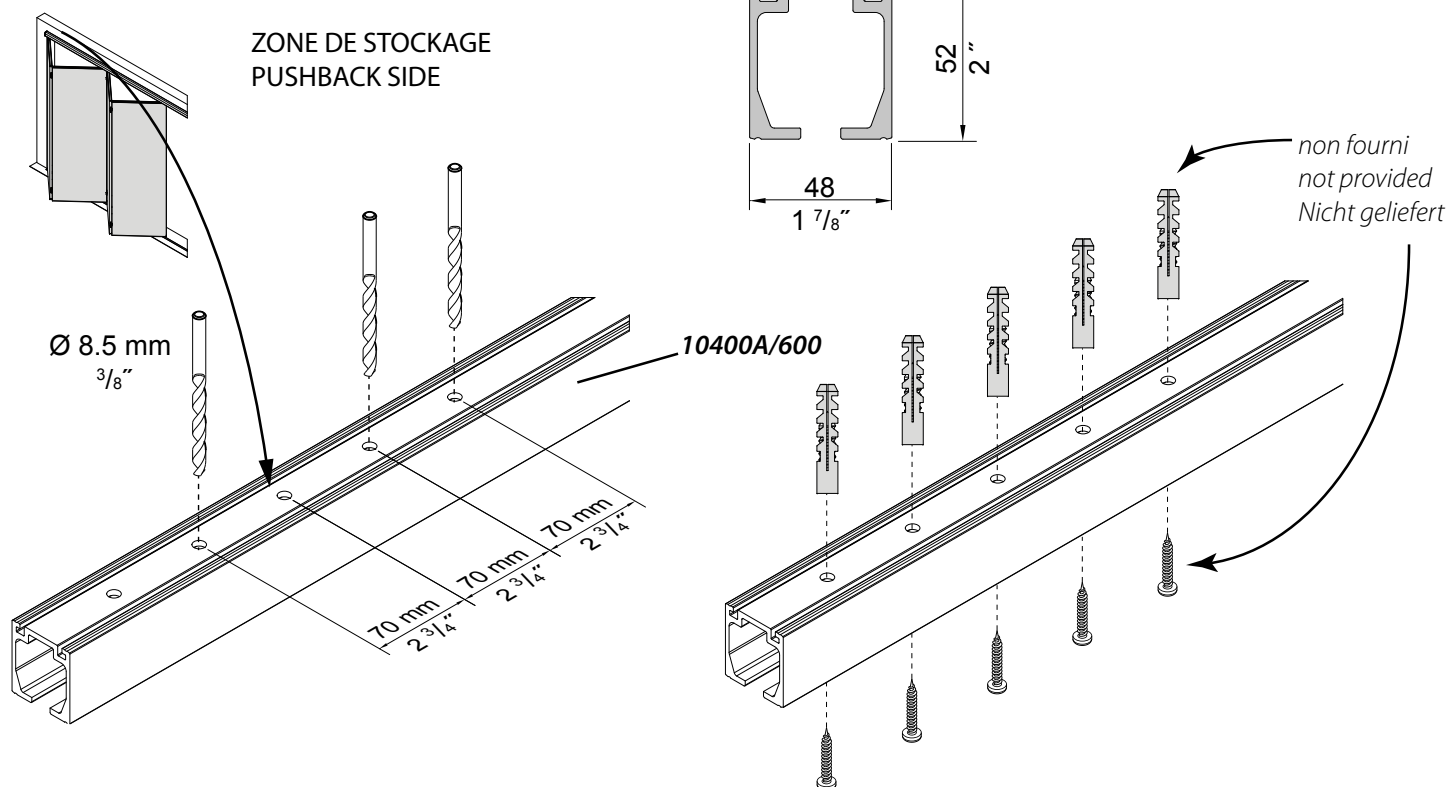

EQUIPEMENT DES RAILS EQUIPMENT OF THE TRACKS

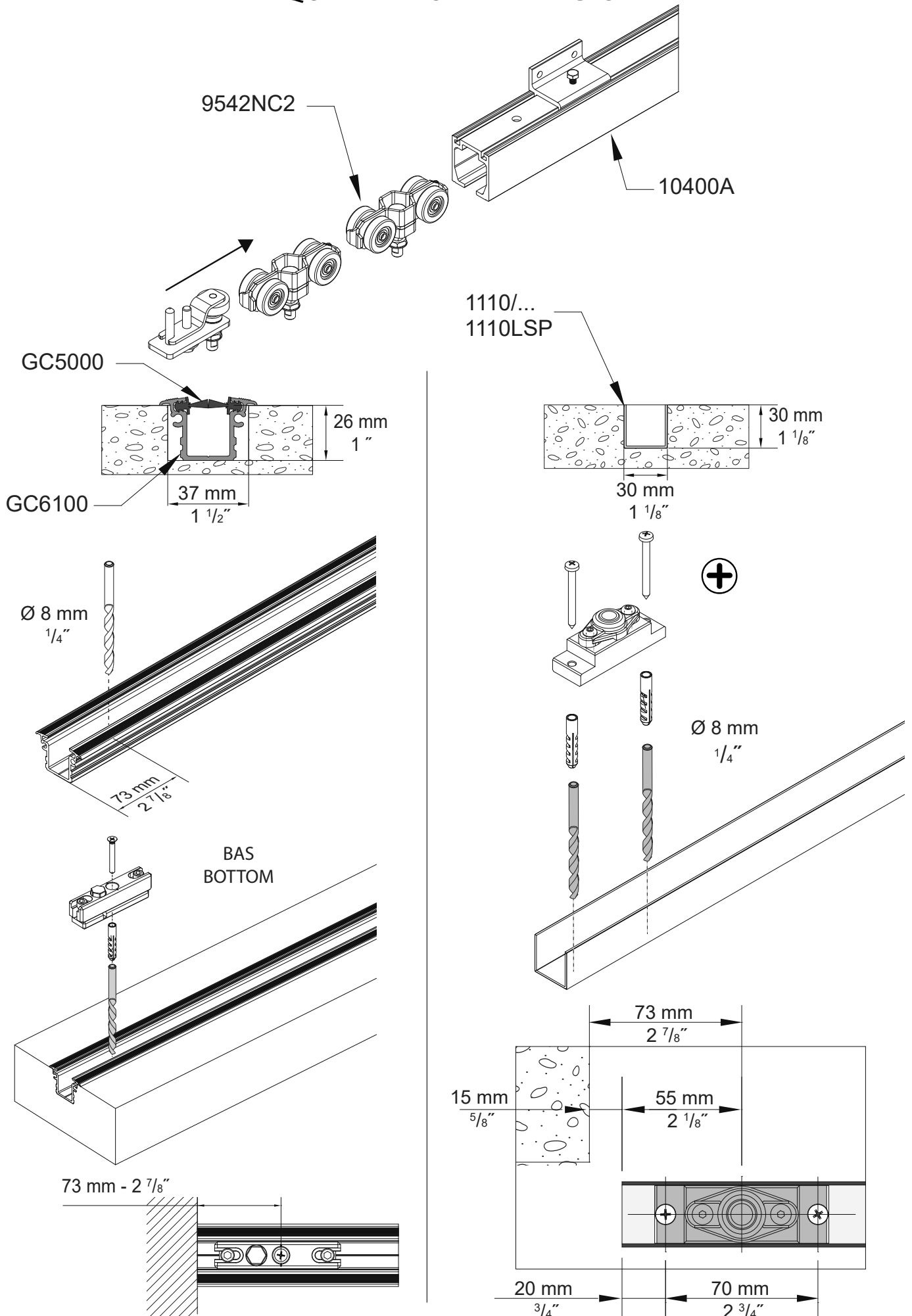

MONTAGE PIVOT HAUT MOUNTING OF THE UPPER PIVOT

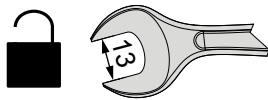
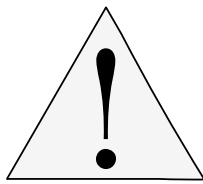
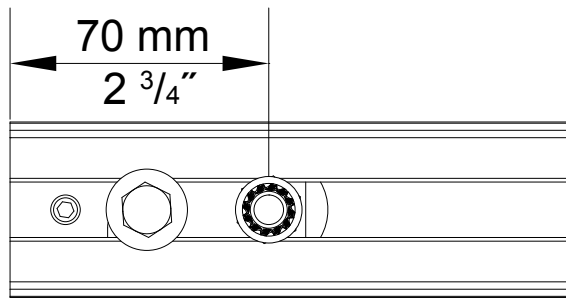
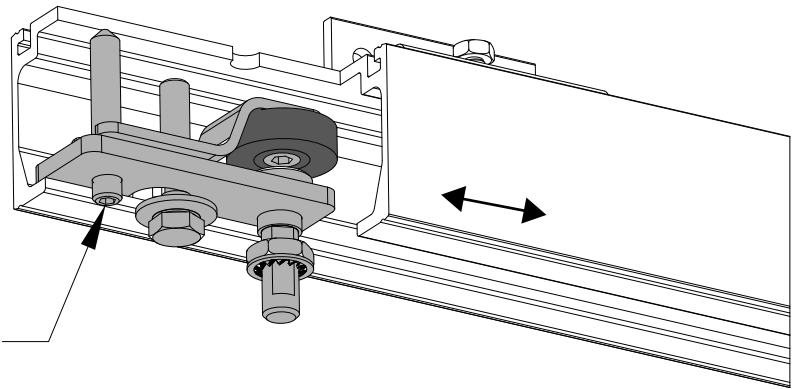
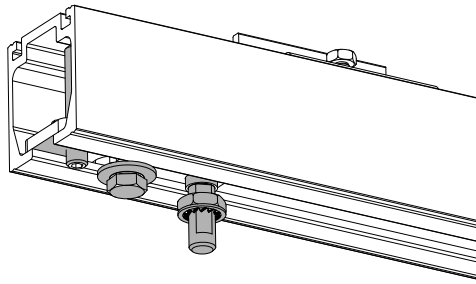

Dévisser entièrement avant
montage du 1er panneau
Completely unscrew before
assembly of the 1st panel

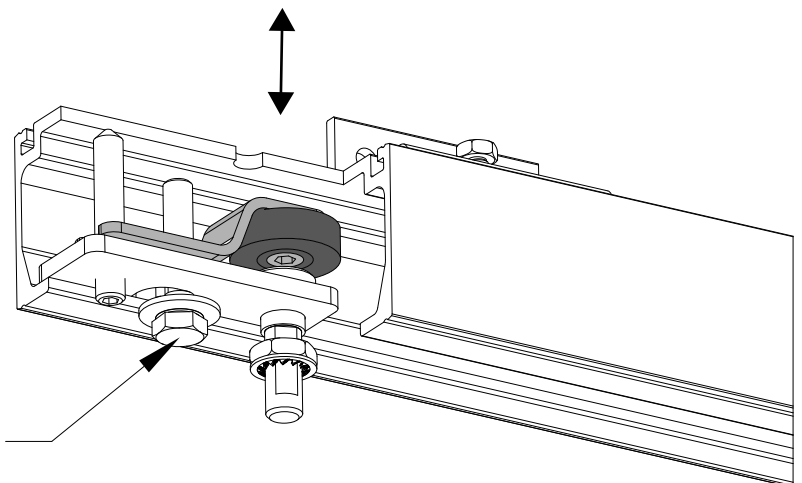

MONTAGE DU 1er PANNEAU MOUNTING OF THE 1st PANEL

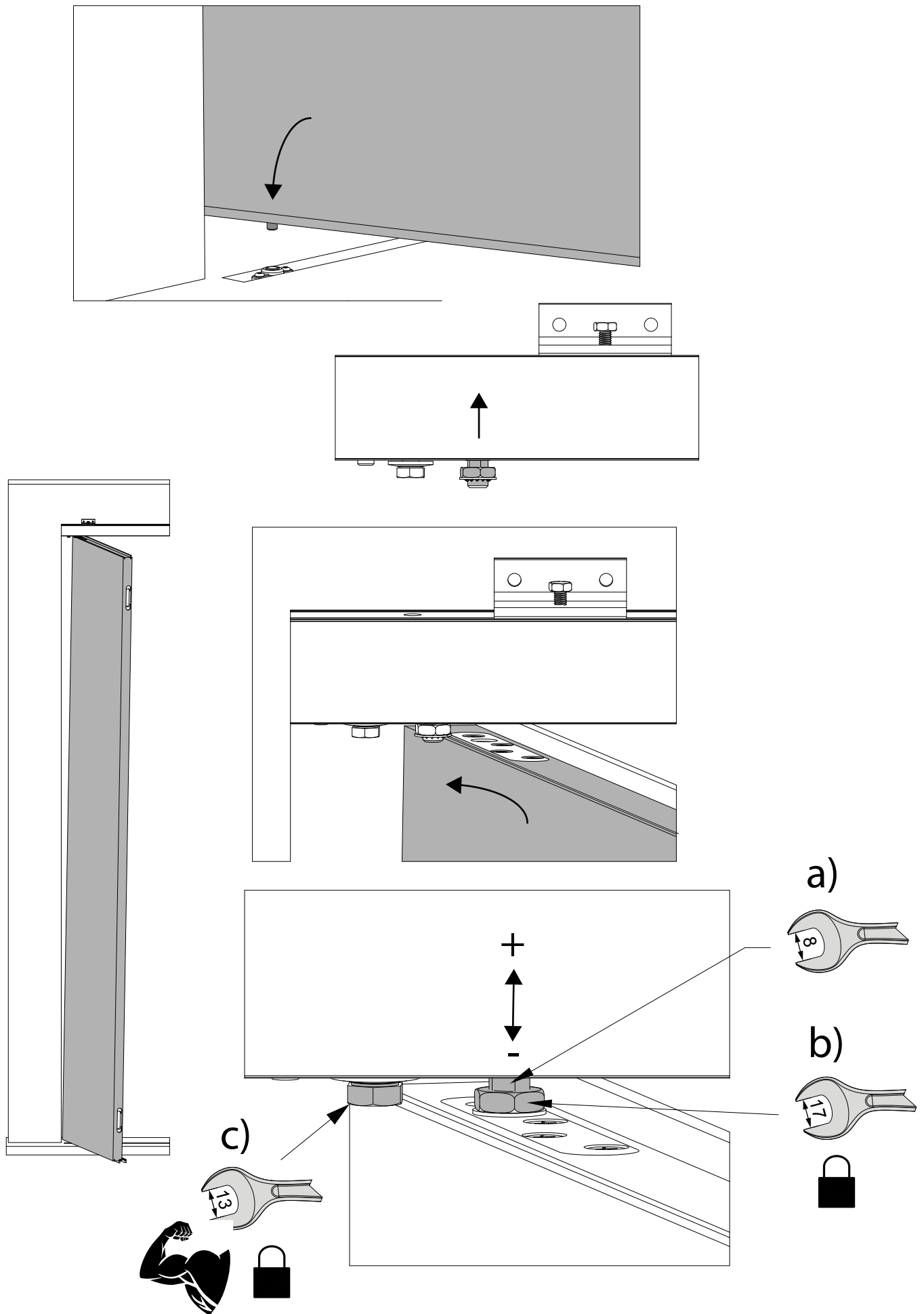

RÉGLAGES ADJUSTMENTS

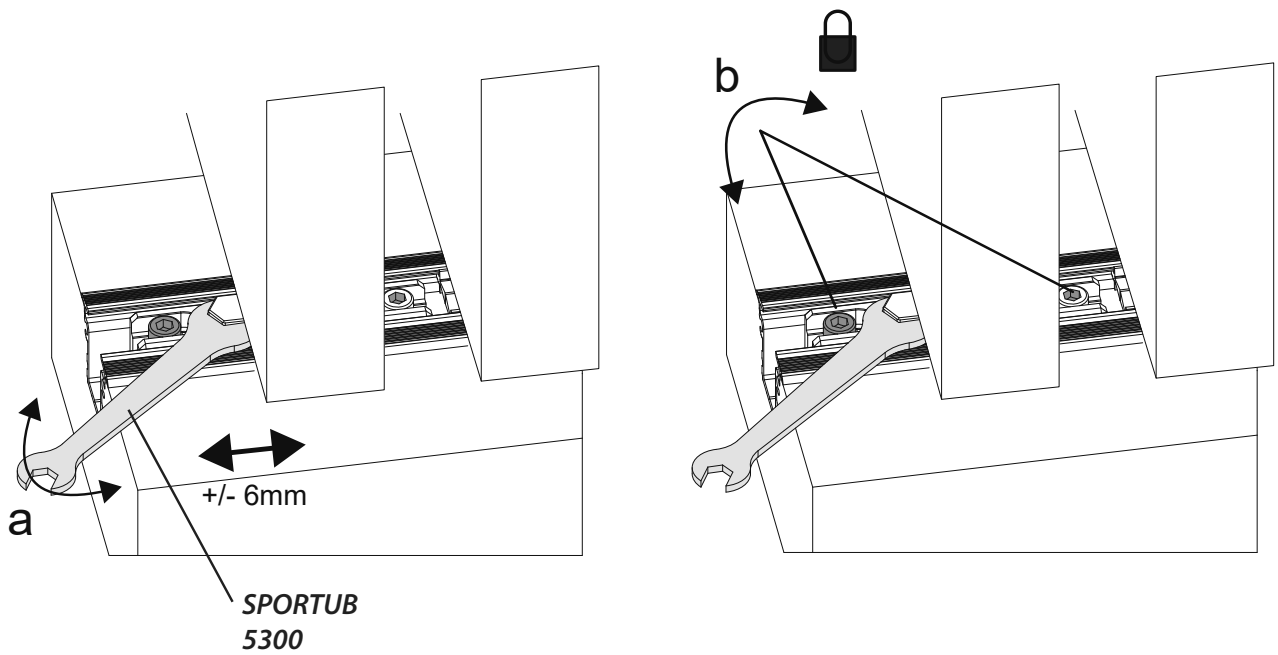
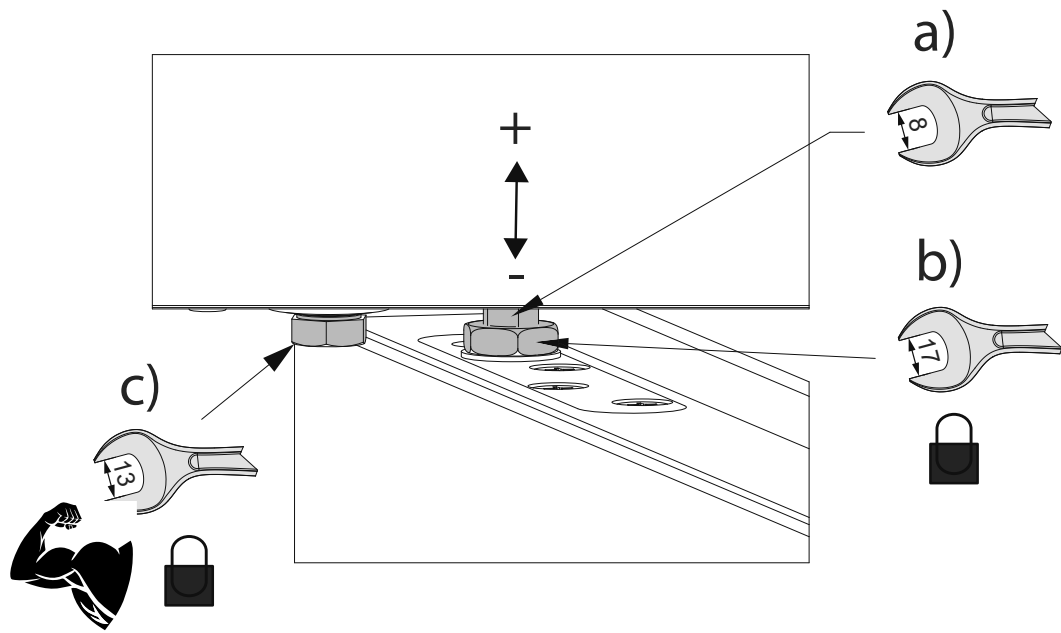

OPTIONS

