



NOTICE DE MONTAGE
MONTAGEANLEITUNG
INSTRUCTIONS FOR ASSEMBLY
INSTRUCCIONES DE MONTAJE

NM OPENTEC F80



SYSTÈME PLIANT POUR CLOISON TOUT VERRE
BESCHLAG FÜR GANZGLAS-FALTWÄNDE
FOLDING SYSTEM FOR ALL-GLASS WALLS
HARRAJE PARA MAMPARAS PLEGABLES ENTERAMENTE DE CRISTAL

Poids maximal des panneaux Maximales Gewicht Maximum weight Peso máximo	80 KG 176 lbs.
Epaisseur des panneaux Ladendicke Shutter thickness Espesor de las contraventanas	10 mm - $\frac{25}{64}$ " 12 mm - $\frac{15}{32}$ " 12.7 mm - $\frac{1}{2}$ "
Largeur maximale des panneaux Maximale Flügelbreite Maximum panel width Ancho máximo de panel	400-1000 mm 1 ft 3 $\frac{3}{4}$ " - 3 ft 3 $\frac{3}{8}$ "
Nombre maximum de panneaux groupés Maximale Ladenanzahl Maximum number of panels Numero máximo de hojas agrupadas	6 + 6 9000 x 3000 mm 29 ft 6 $\frac{21}{64}$ " - 9 ft 10 $\frac{7}{64}$ "

SLIDSOFT®

Logiciel de calcul
(quantitatif, dimensionnement ...)

Computation software
(quantitative, sizing...)

Berechnungsprogramm
(quantitativ, Größenbestimmung...)

Programa de cálculo
(cuantitativo, dimensionamiento...)

www.mantion.com

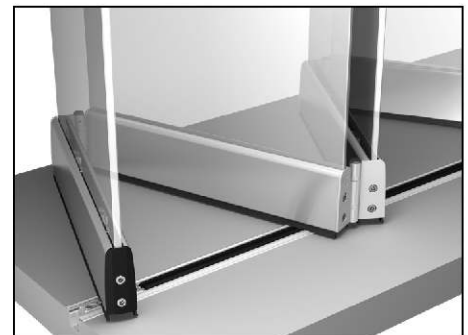

www.slidsoft.com

Pour détailler votre projet, c'est facile !
Il vous suffit de renseigner les dimensions de
votre baie et vos options.
Vous aurez aussi accès au détail complet des
produits et plans.

It is easy to determine the solution!
Simply enter the dimensions of your opening
and your options.
You will also have access to the full details
of the products and plans.

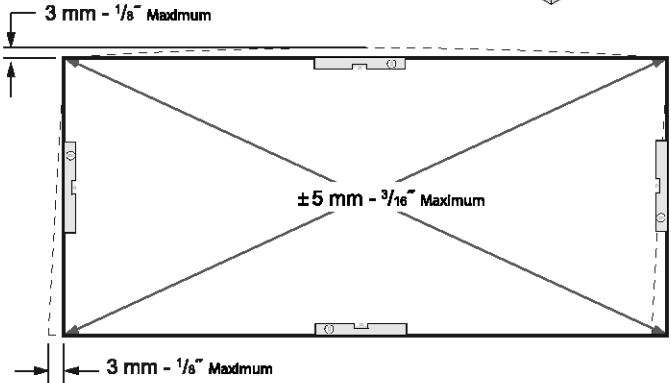
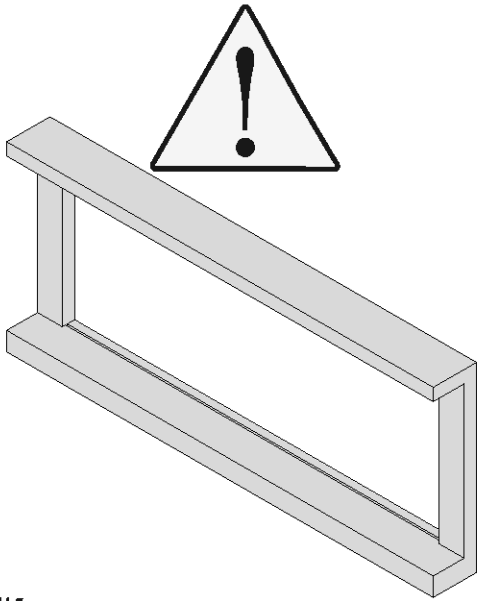
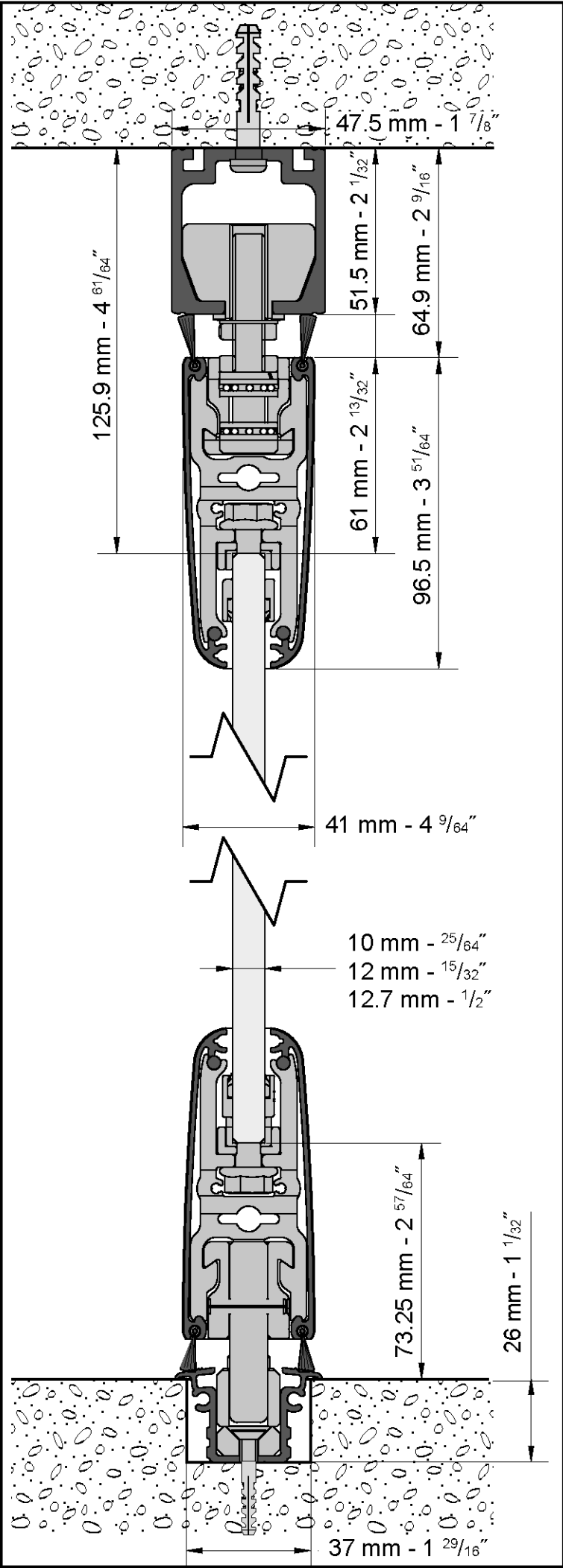

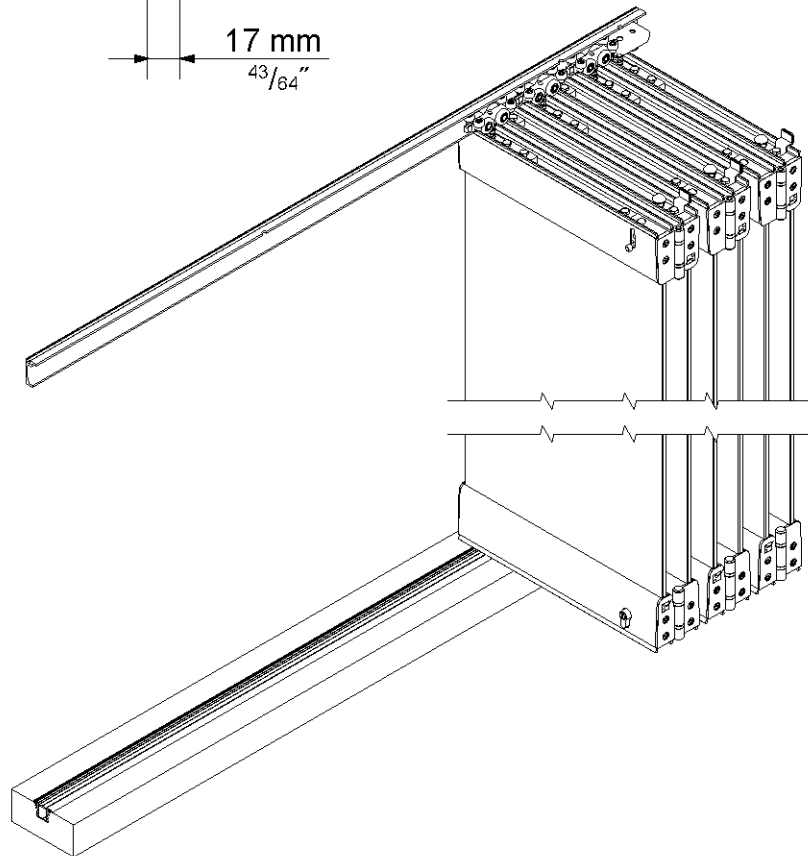
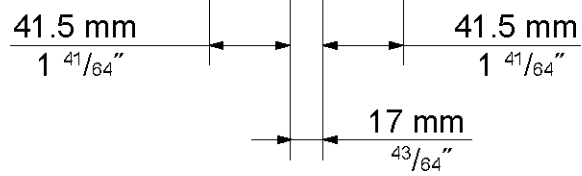
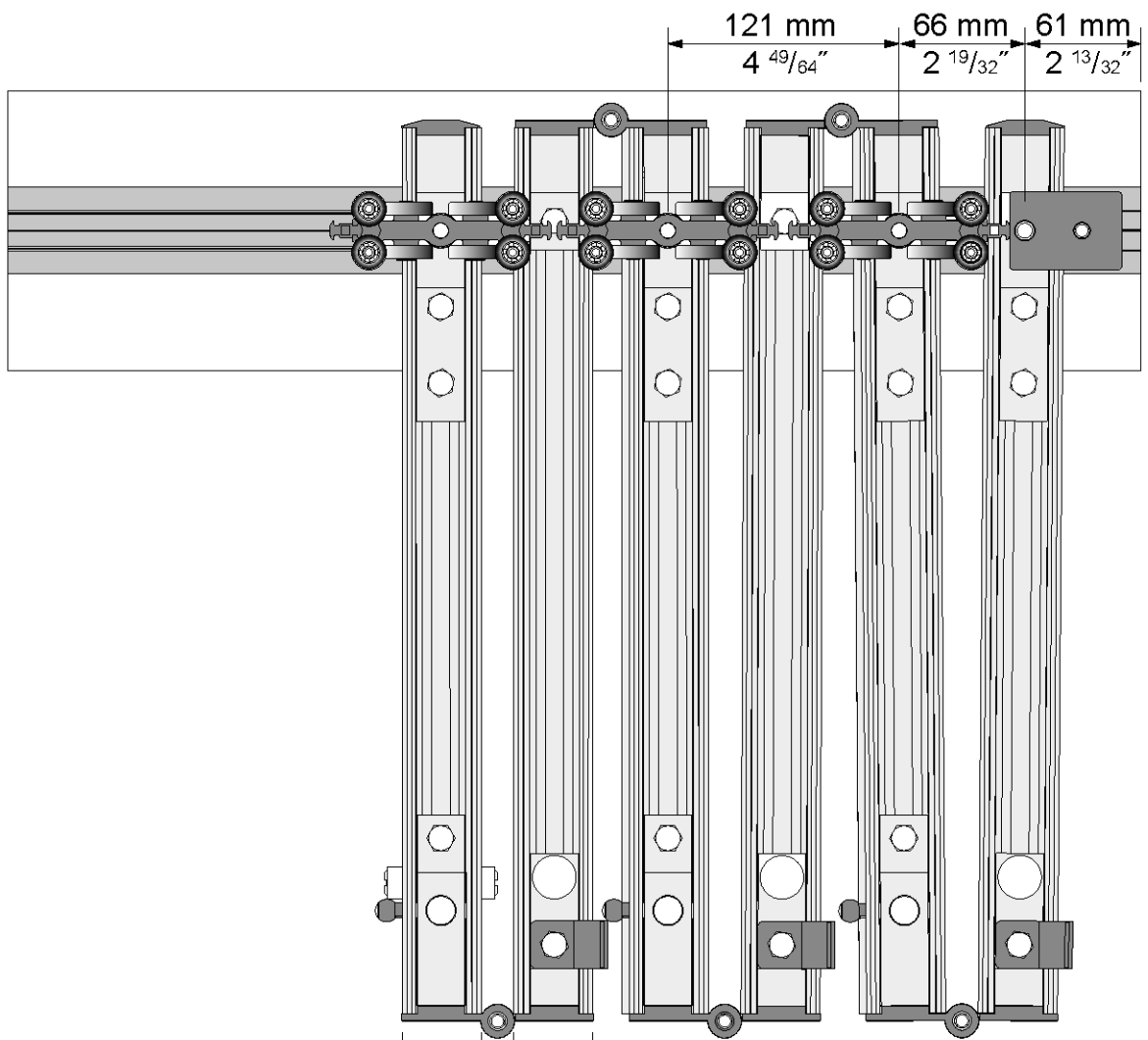

1.

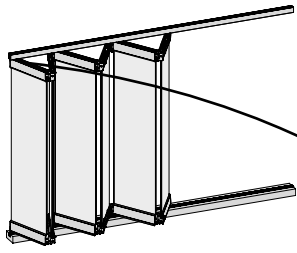

Ø 8.5 mm
2 21/64"

a.

10400A/600

70 mm 2 3/4"
70 mm 2 3/4"
70 mm 2 3/4"

b.

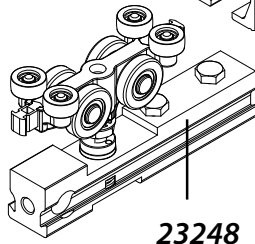

23248

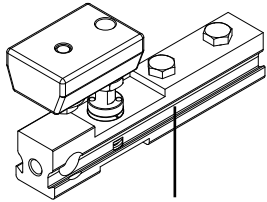

23244

c.

non fourni
not provided
Nicht geliefert



il est recommandé de bien nettoyer
l'intérieur des profils

it is recommended that the inside of the
tracks be correctly cleaned

die Innenseiten der Profi le
gut zu reinigen

d.

Ø 8 mm
5/16"

voir p. 14
See p. 14
Sieh s. 14

61 mm
2 13/32"

e.

26 mm - 1 1/32"

GC6100

37 mm
1 29/16"

2.

a.

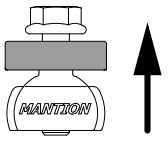

b.

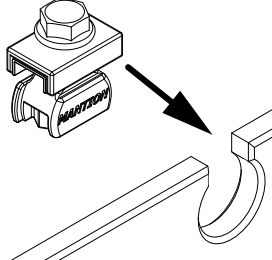

c.

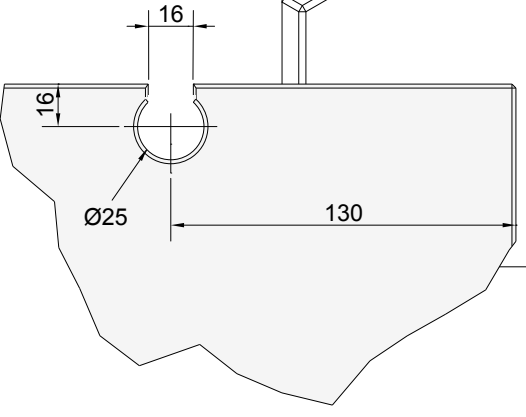
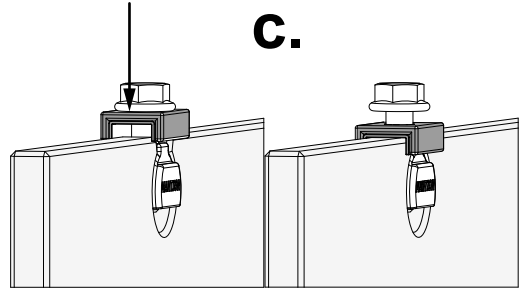

3.

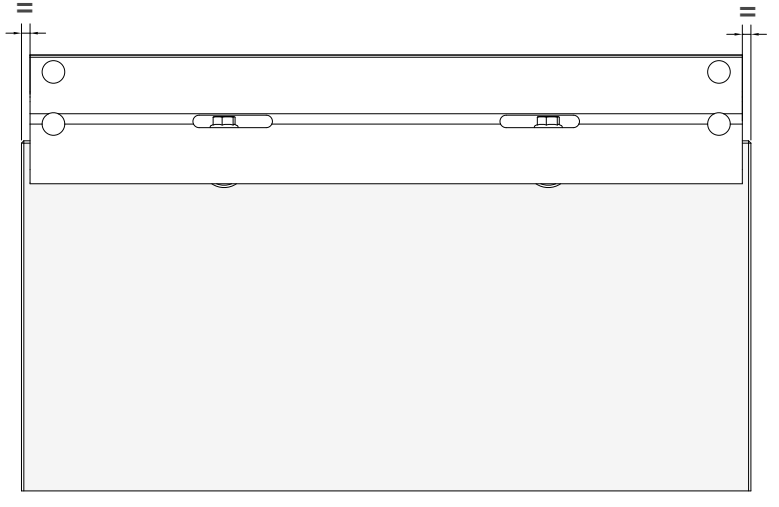
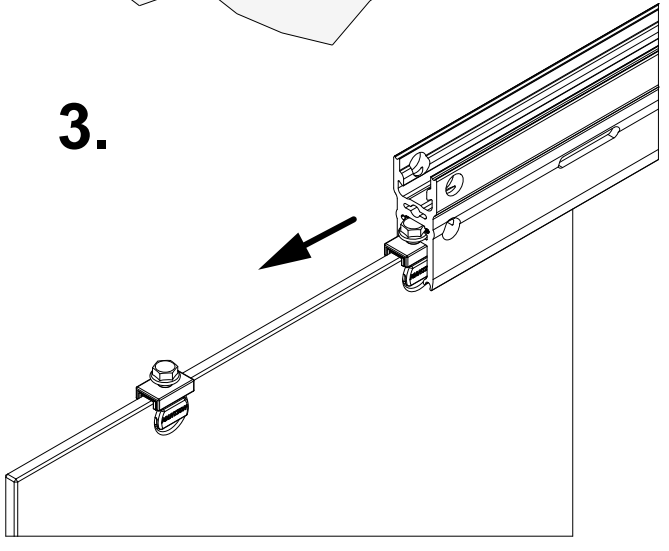

F < 8 Nm
Ne pas serrer
Nicht festziehen
Do not tighten
No apriete

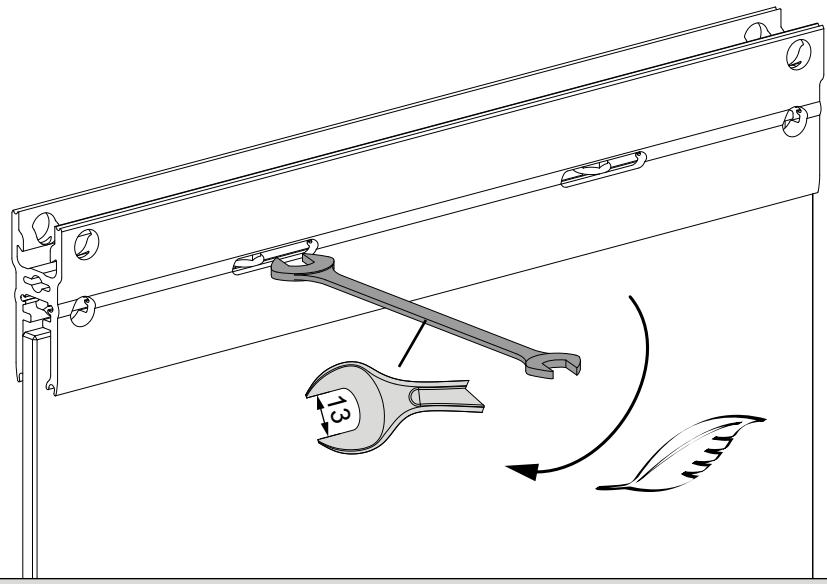

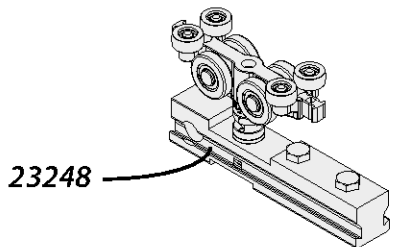

23248

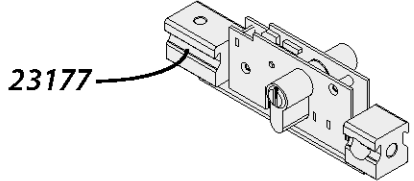
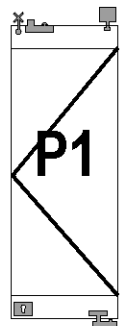
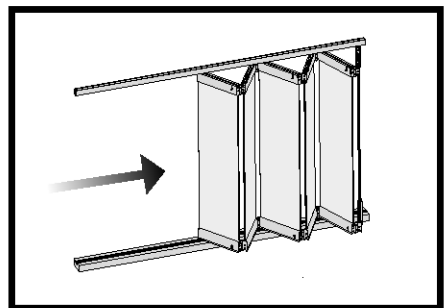

23177

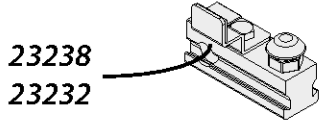
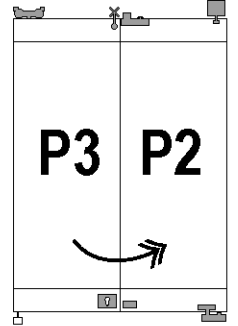

23238
23232

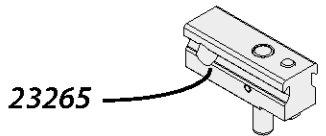
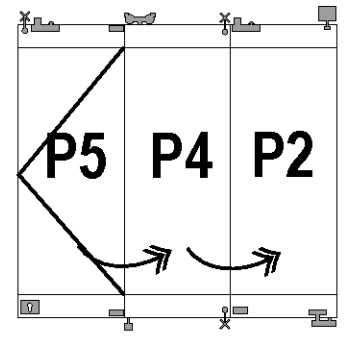

23265

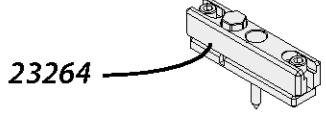

23264

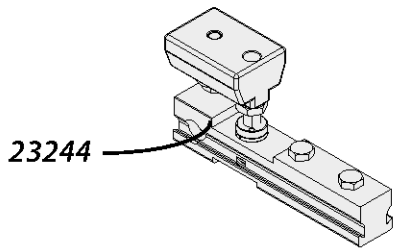
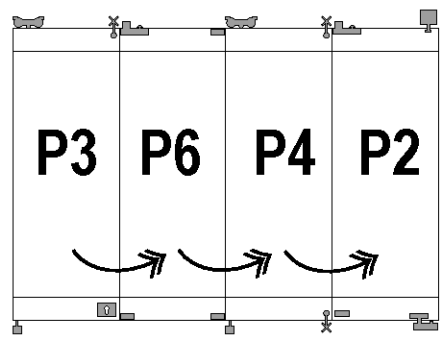

23244

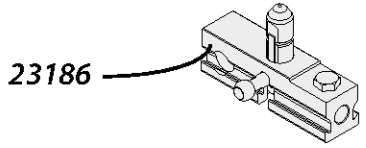

23186



optionnel en partie haute
optional in upper position

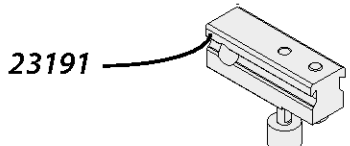
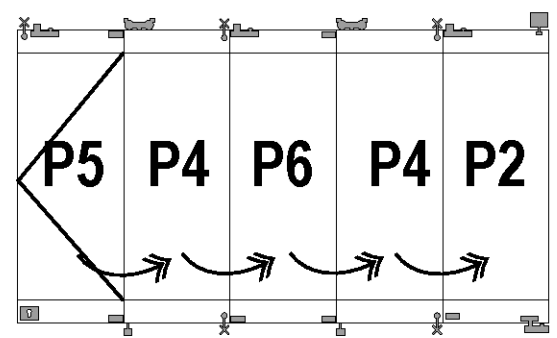

23191



23206

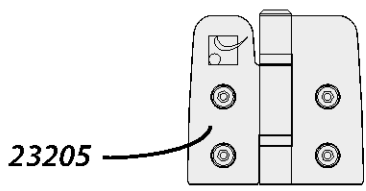
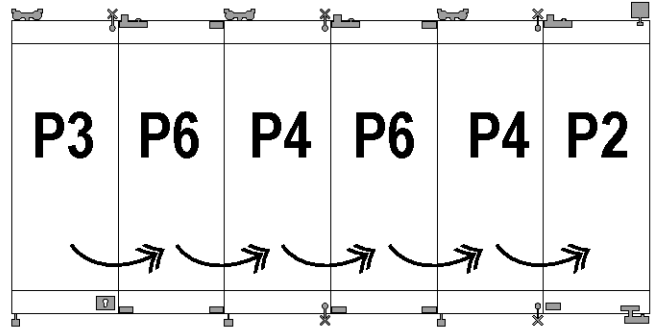

23205

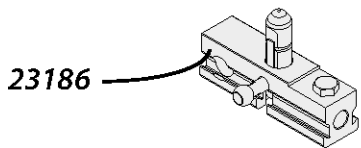
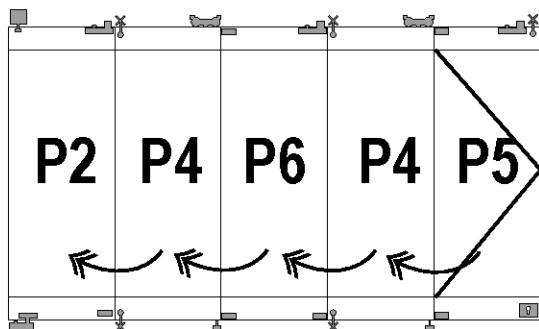
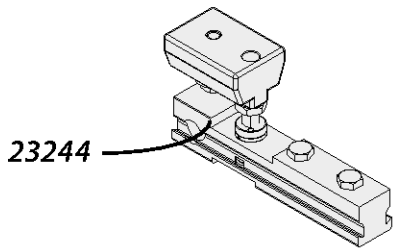
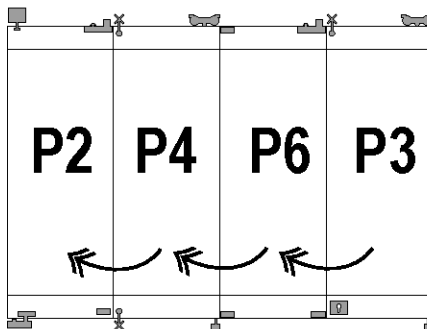
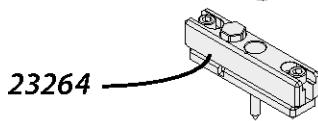
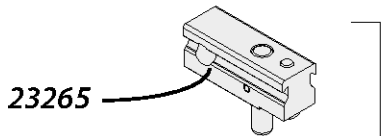
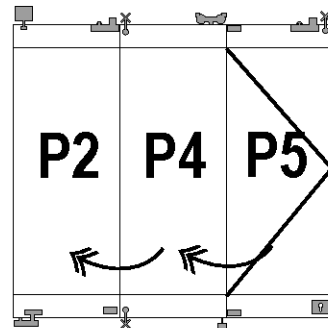
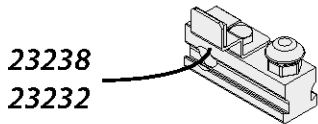
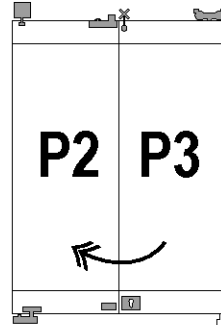
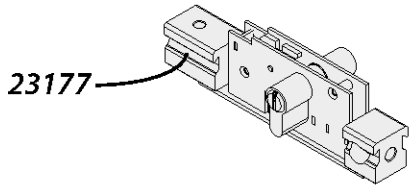
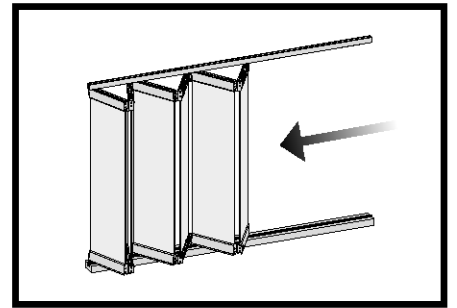
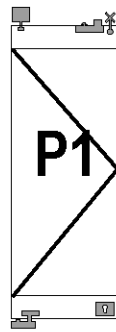
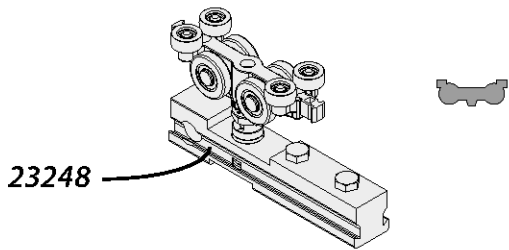

*optionnel en partie haute
optional in upper position*

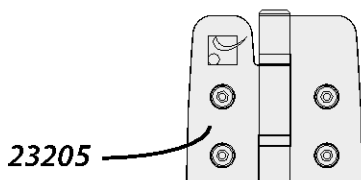
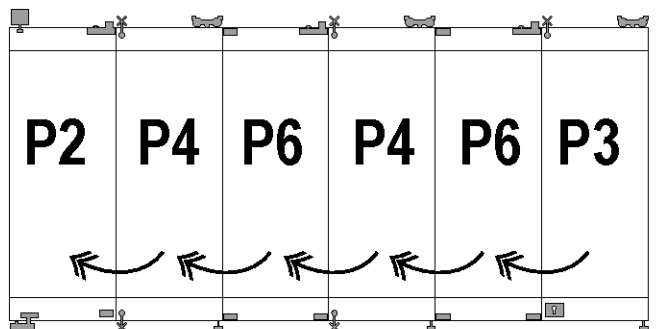
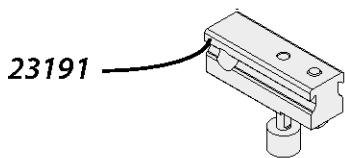

P1

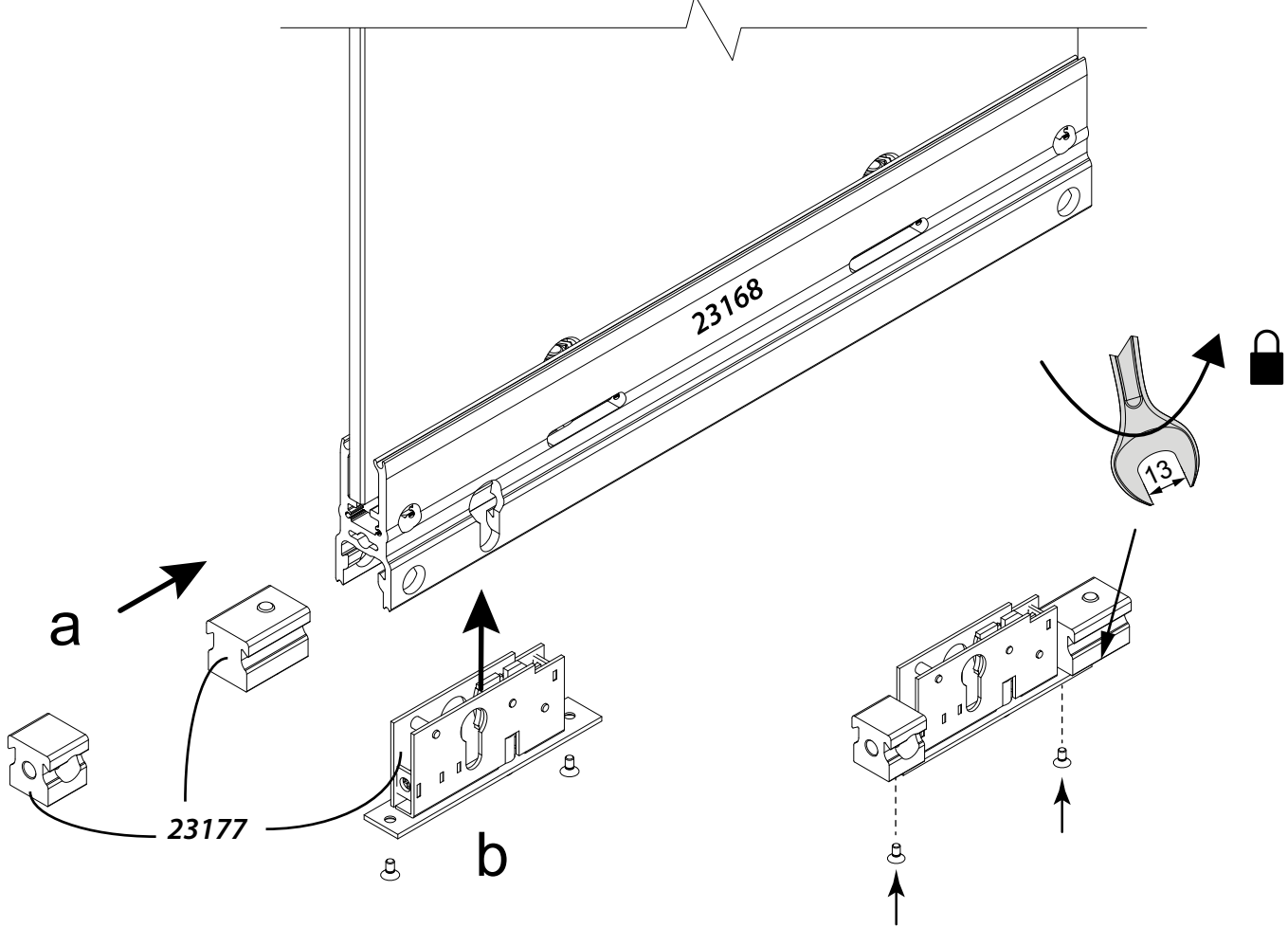
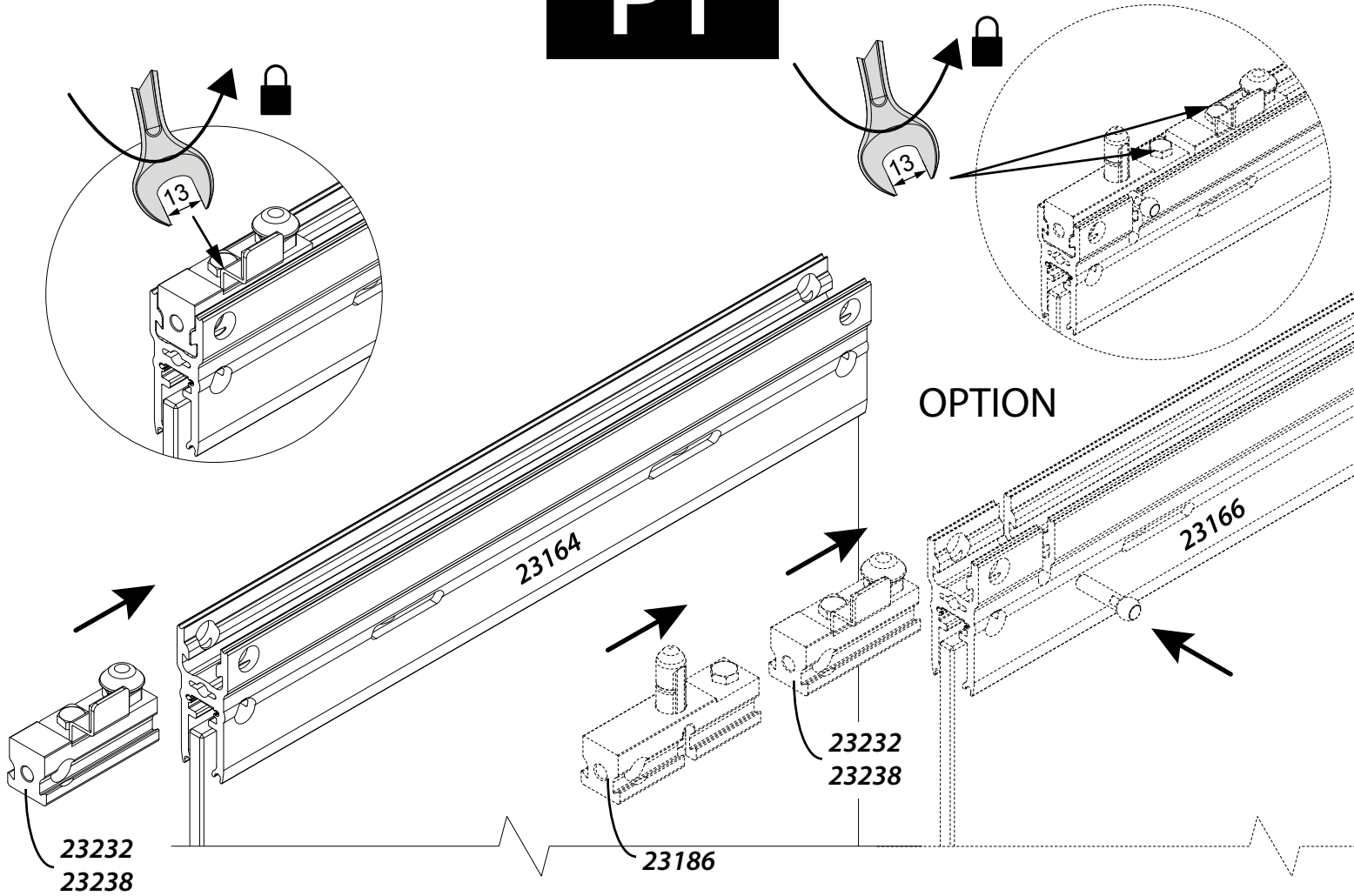

P2

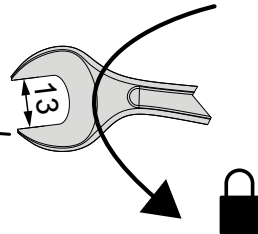
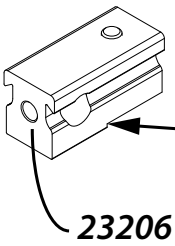
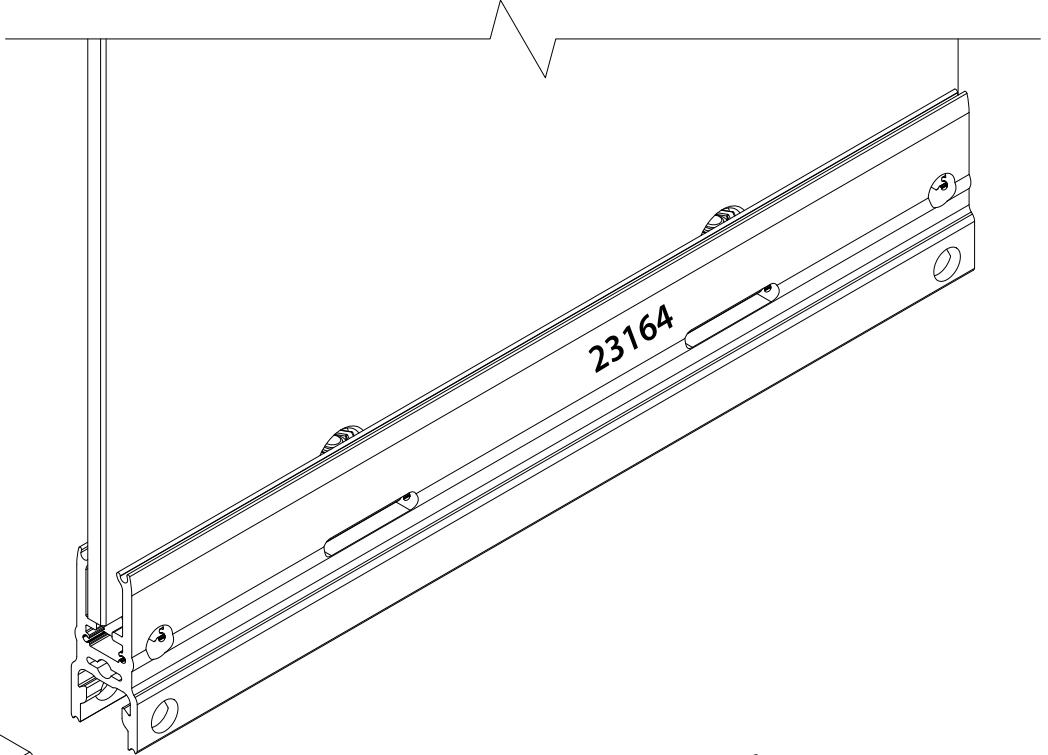
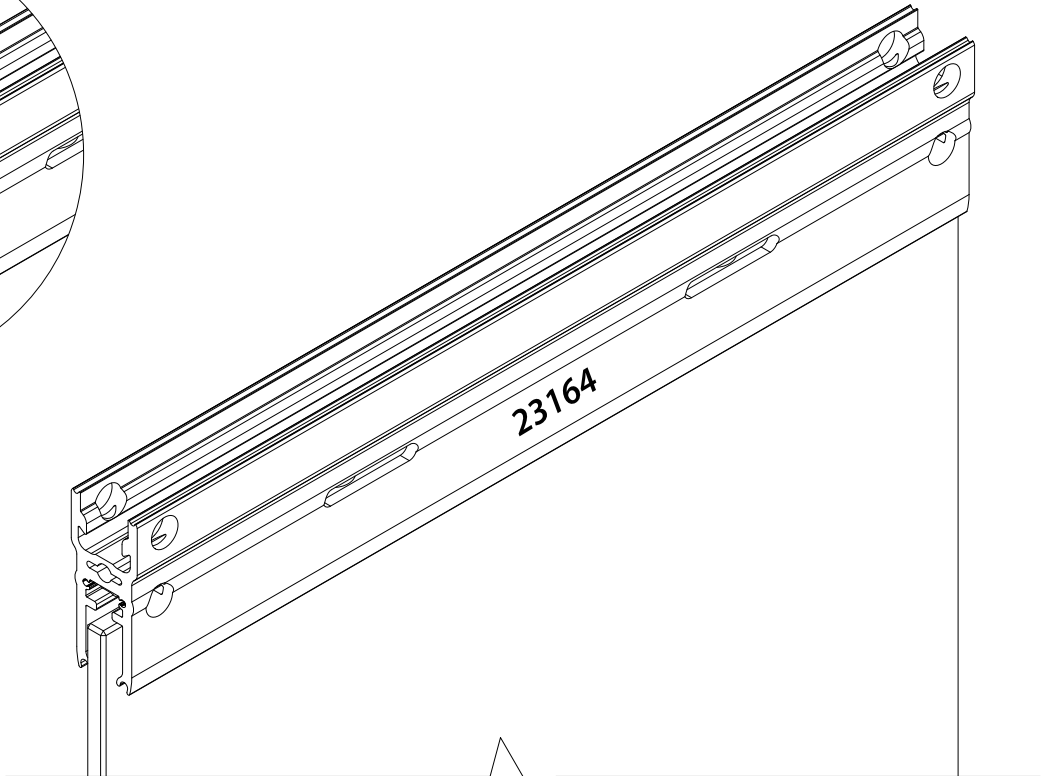
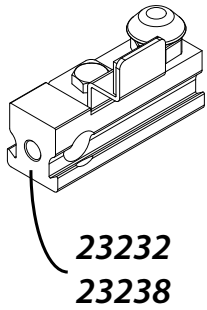
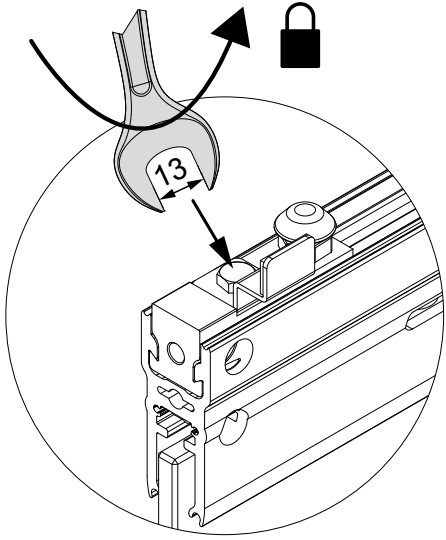

P3

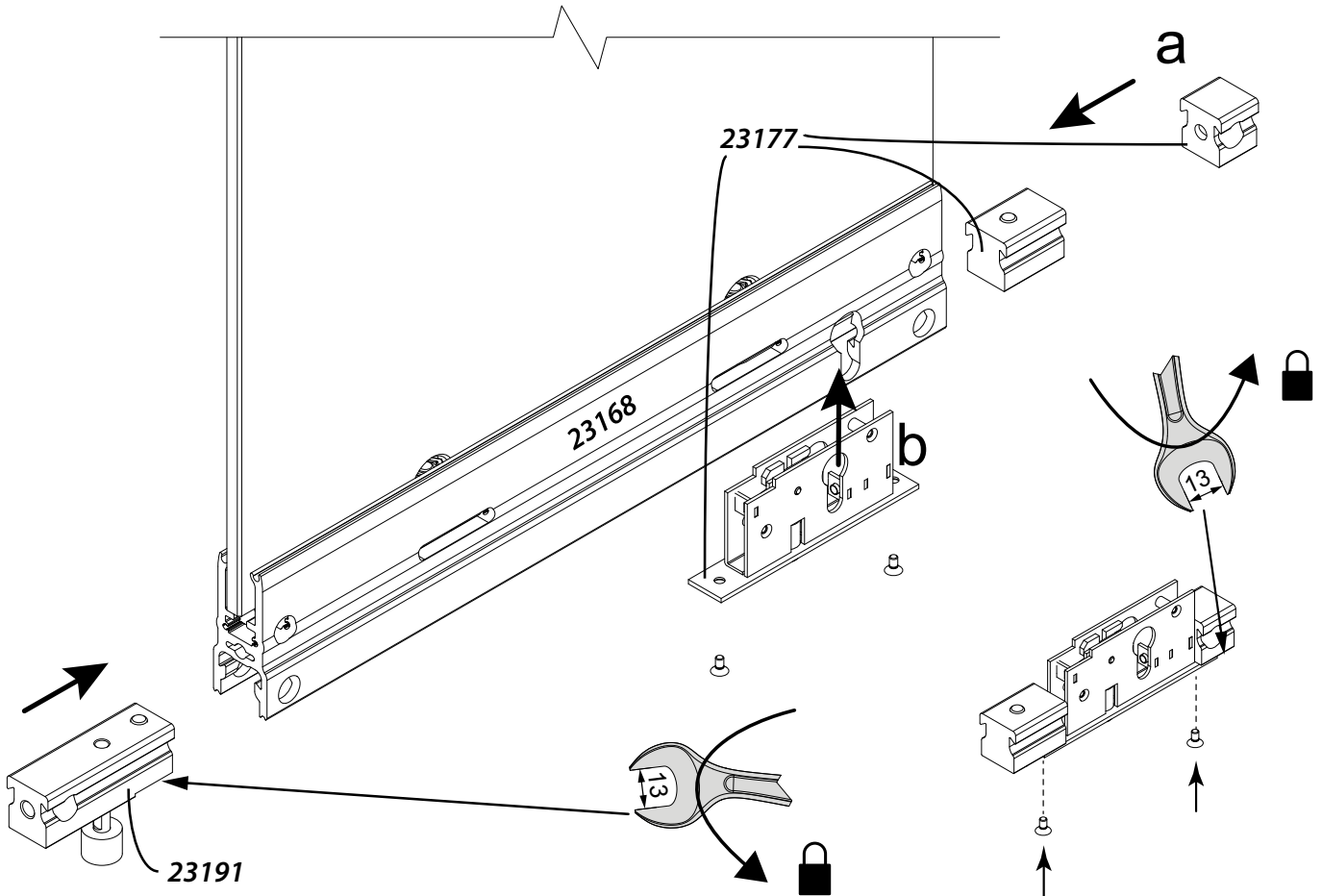
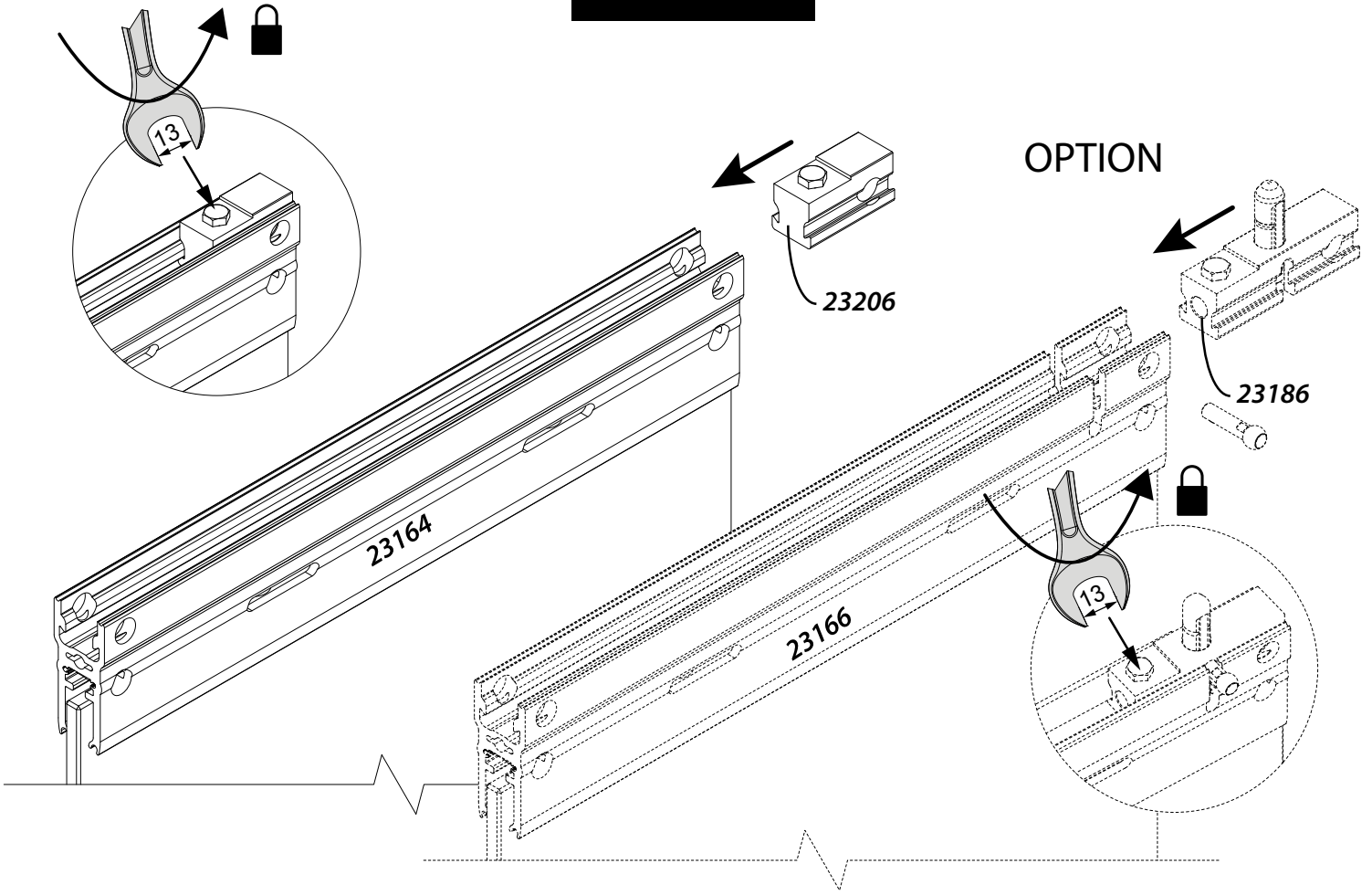

P4

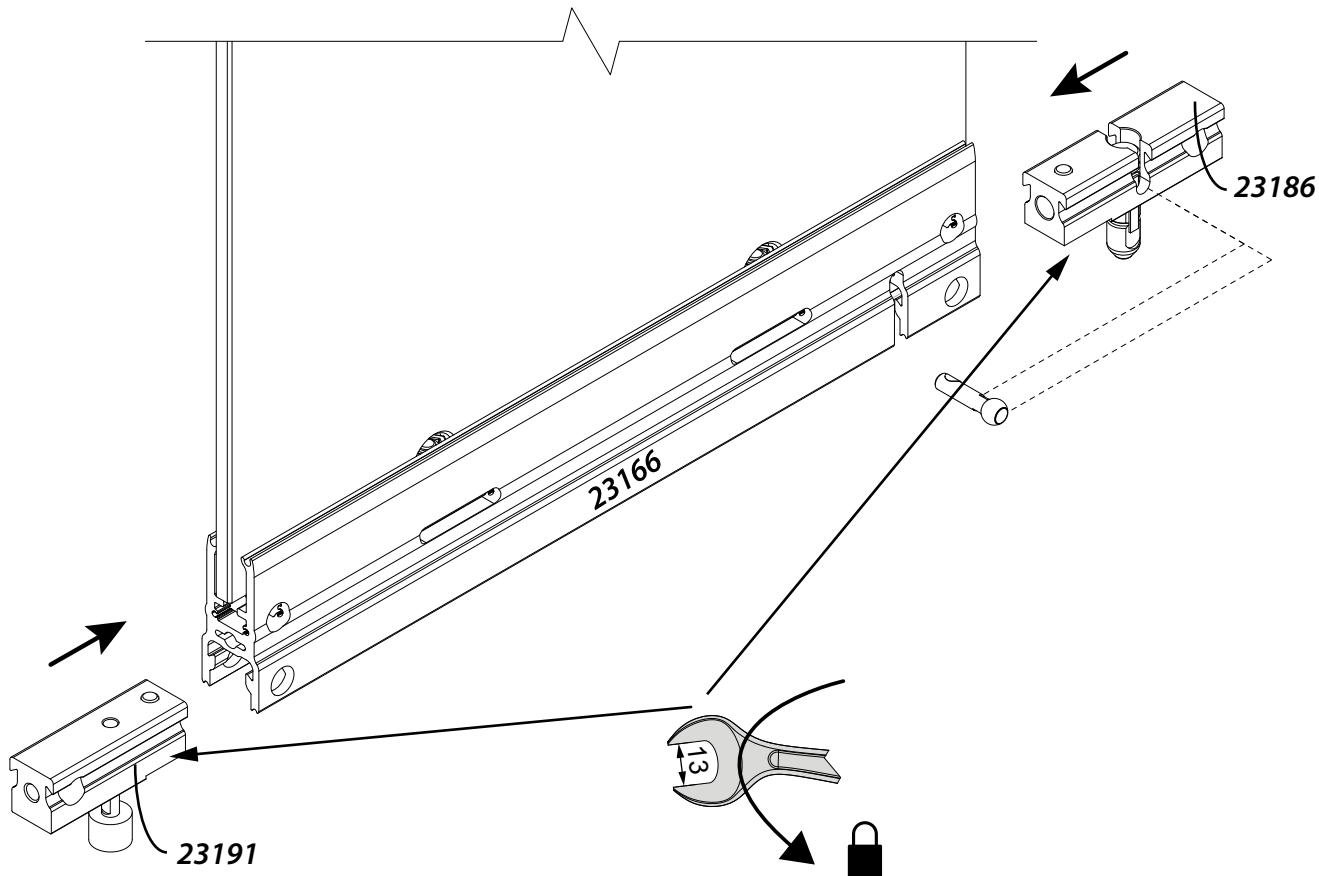
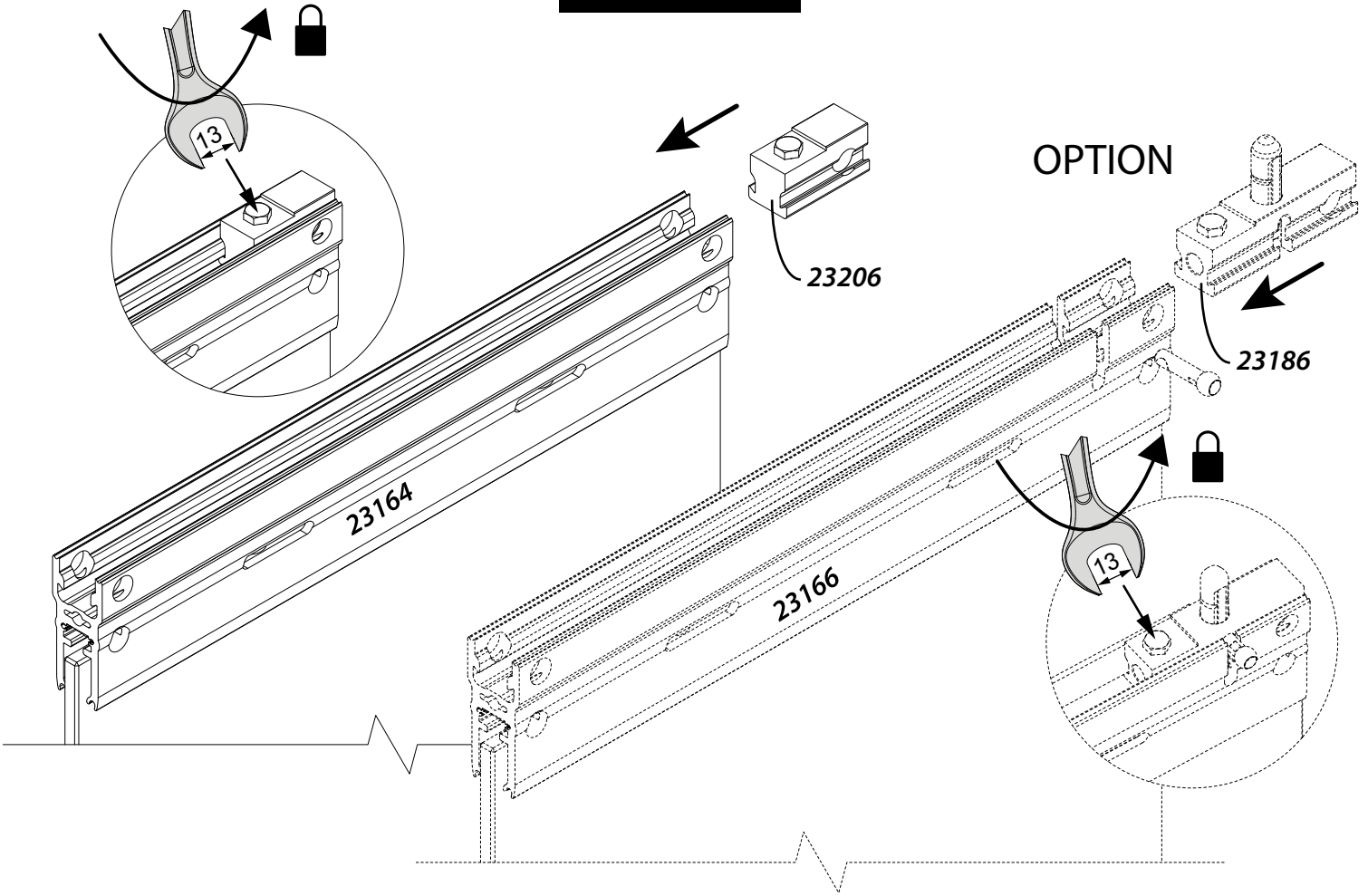

P5

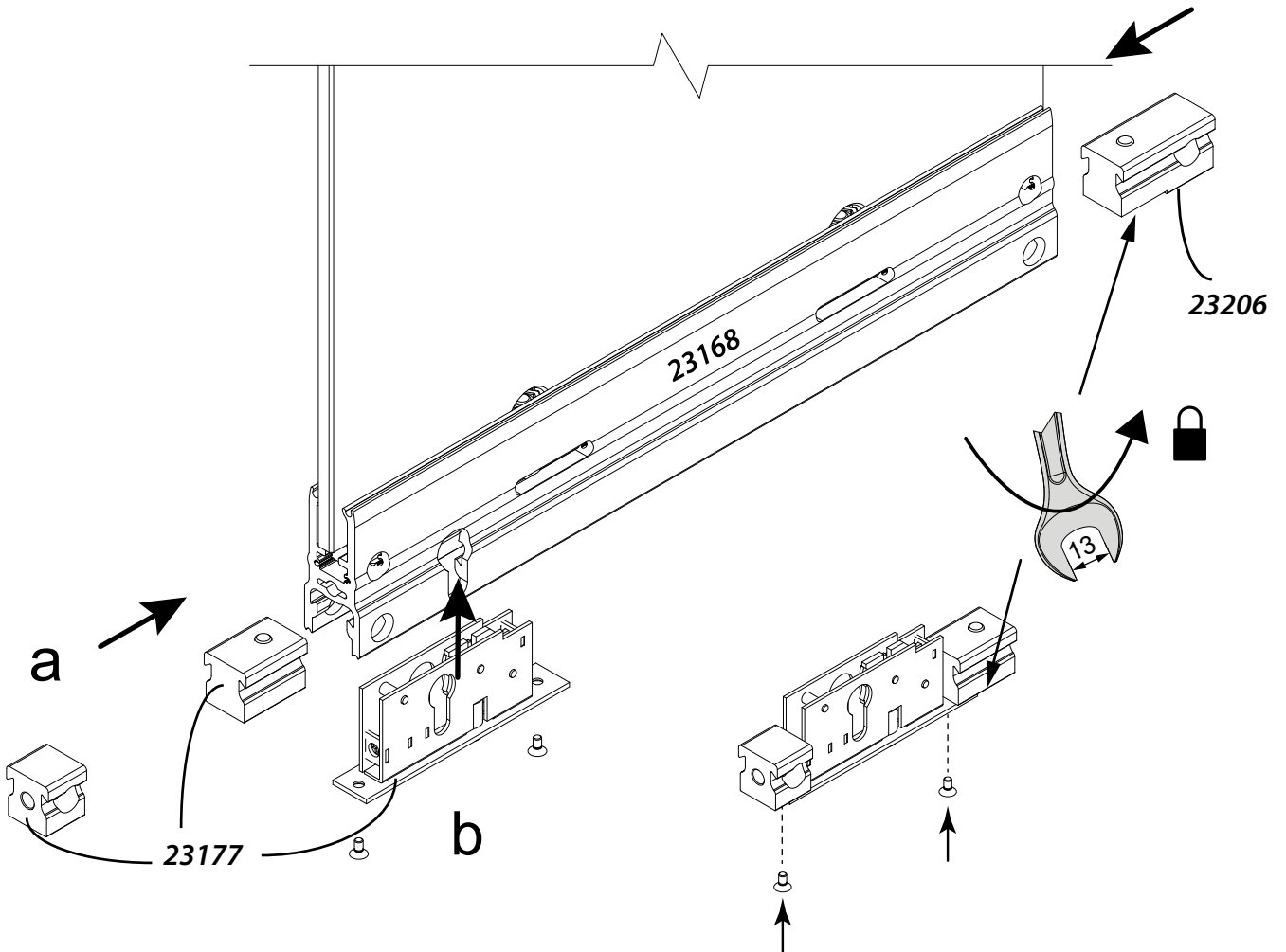
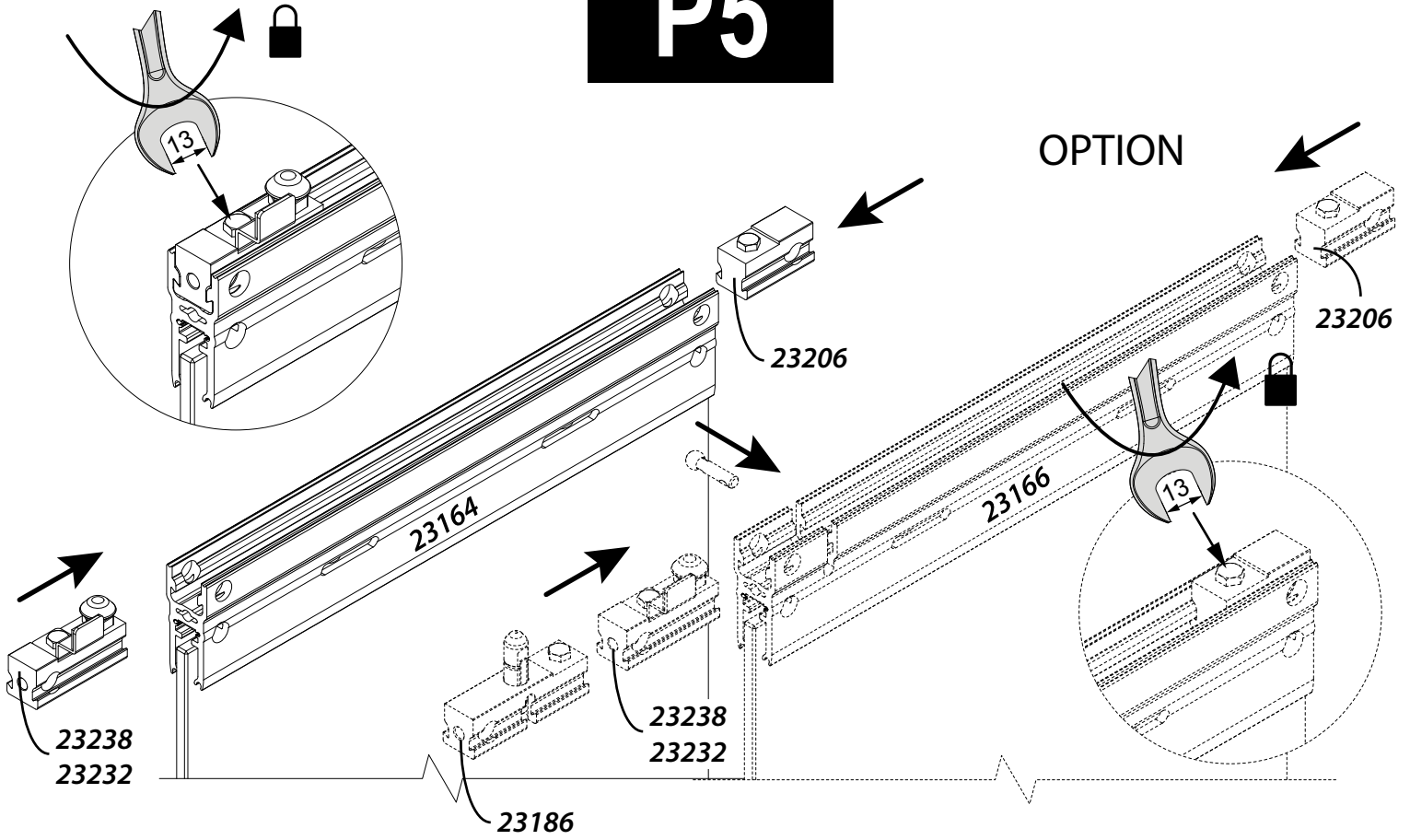

P6

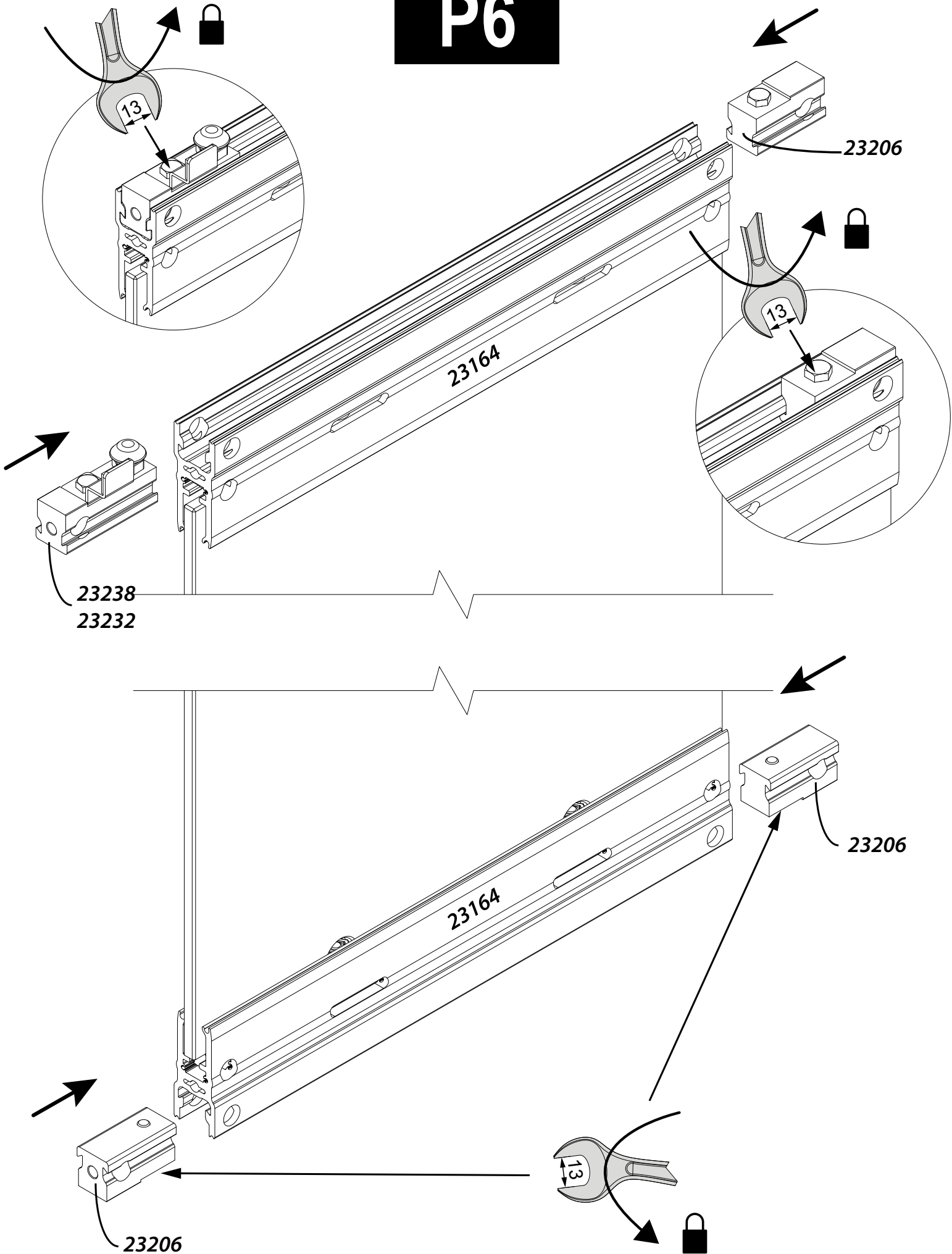

Montage du 1er panneau - Assembly of the 1st panel

Montage der ersten Tür - Montaje del primer panel

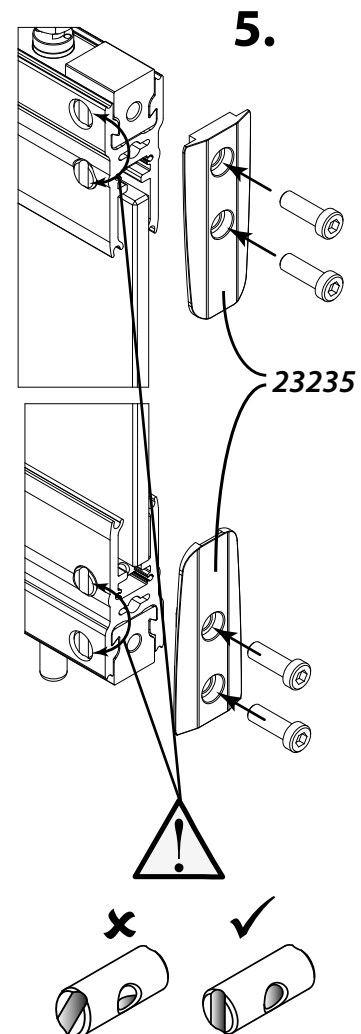
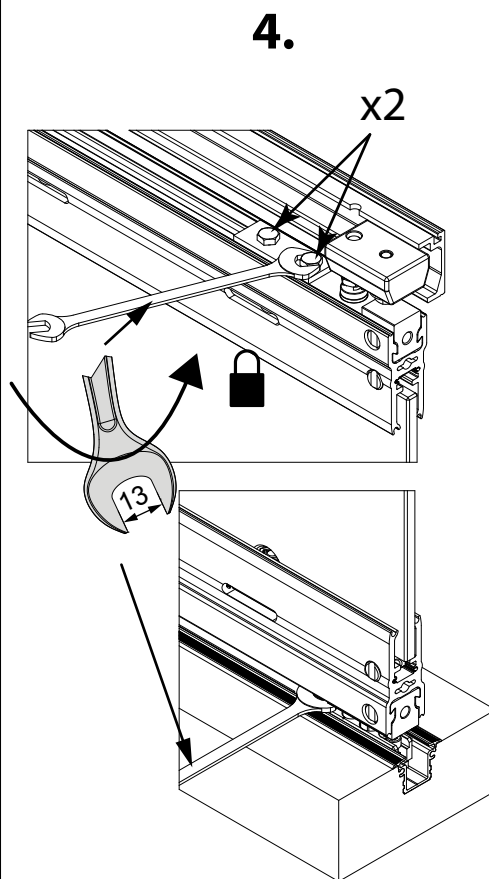
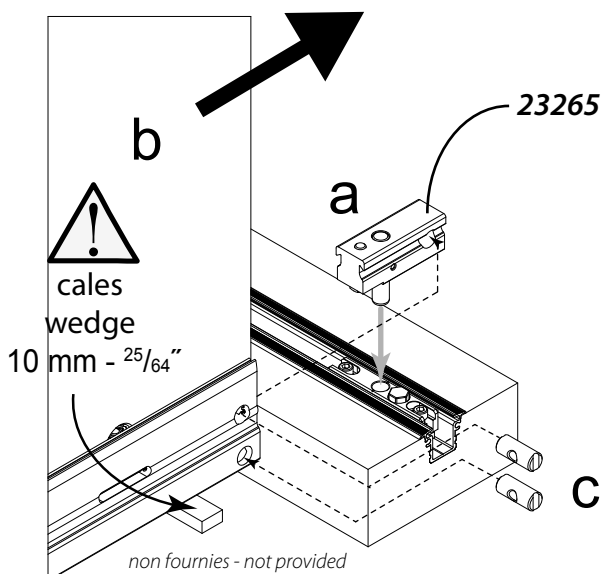
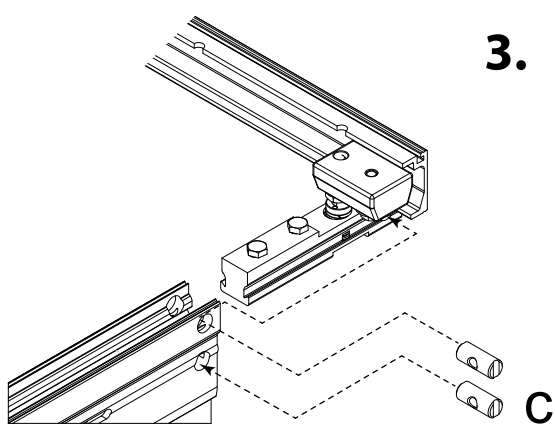
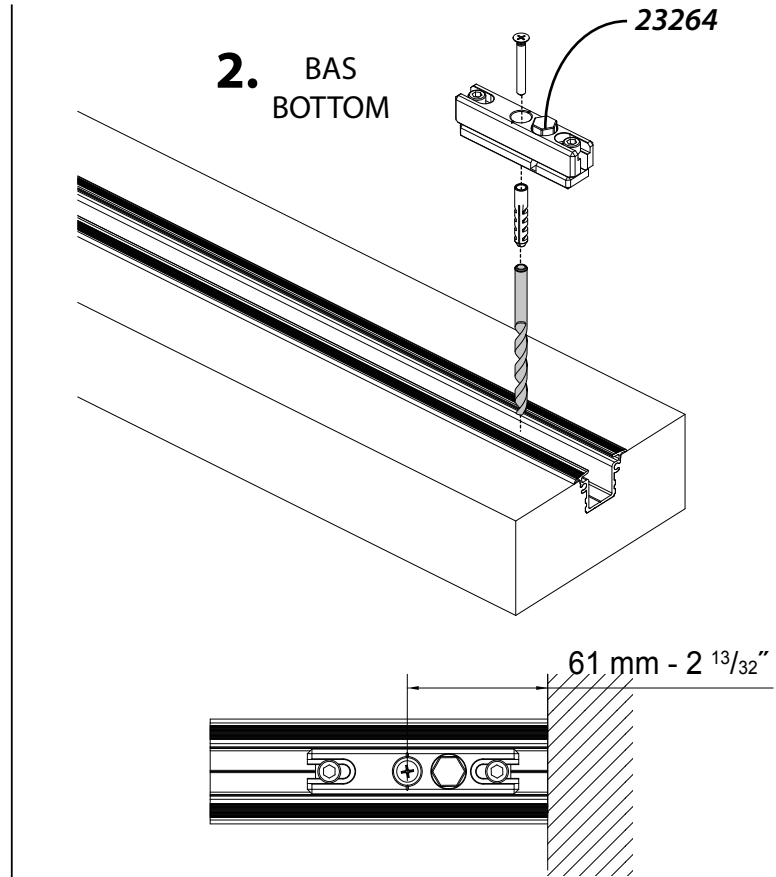
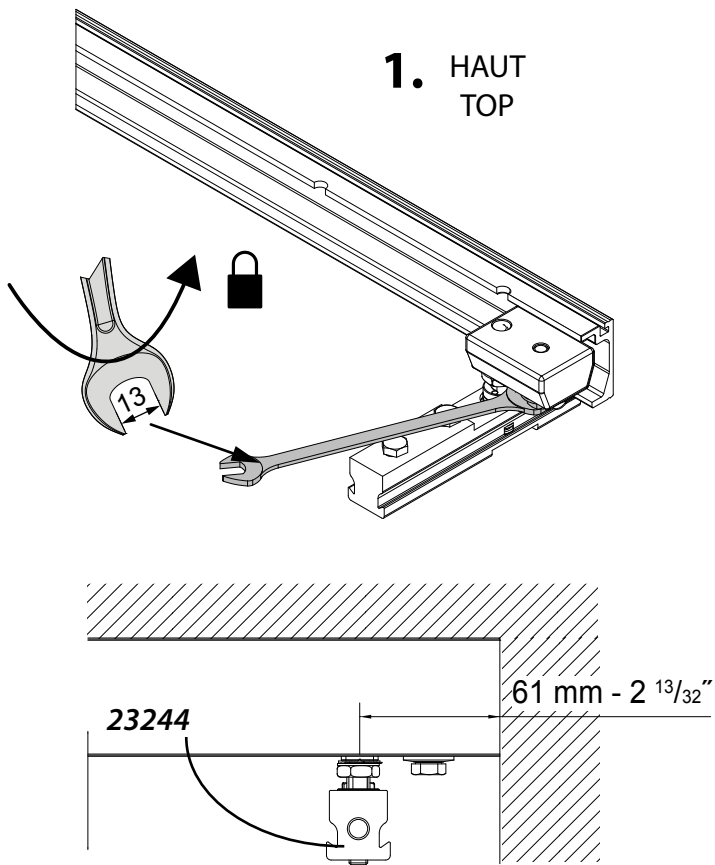

Montage du 2ème panneau - Assembly of the 2nd panel
Montage der zweite Tür - Montaje del segundo panel

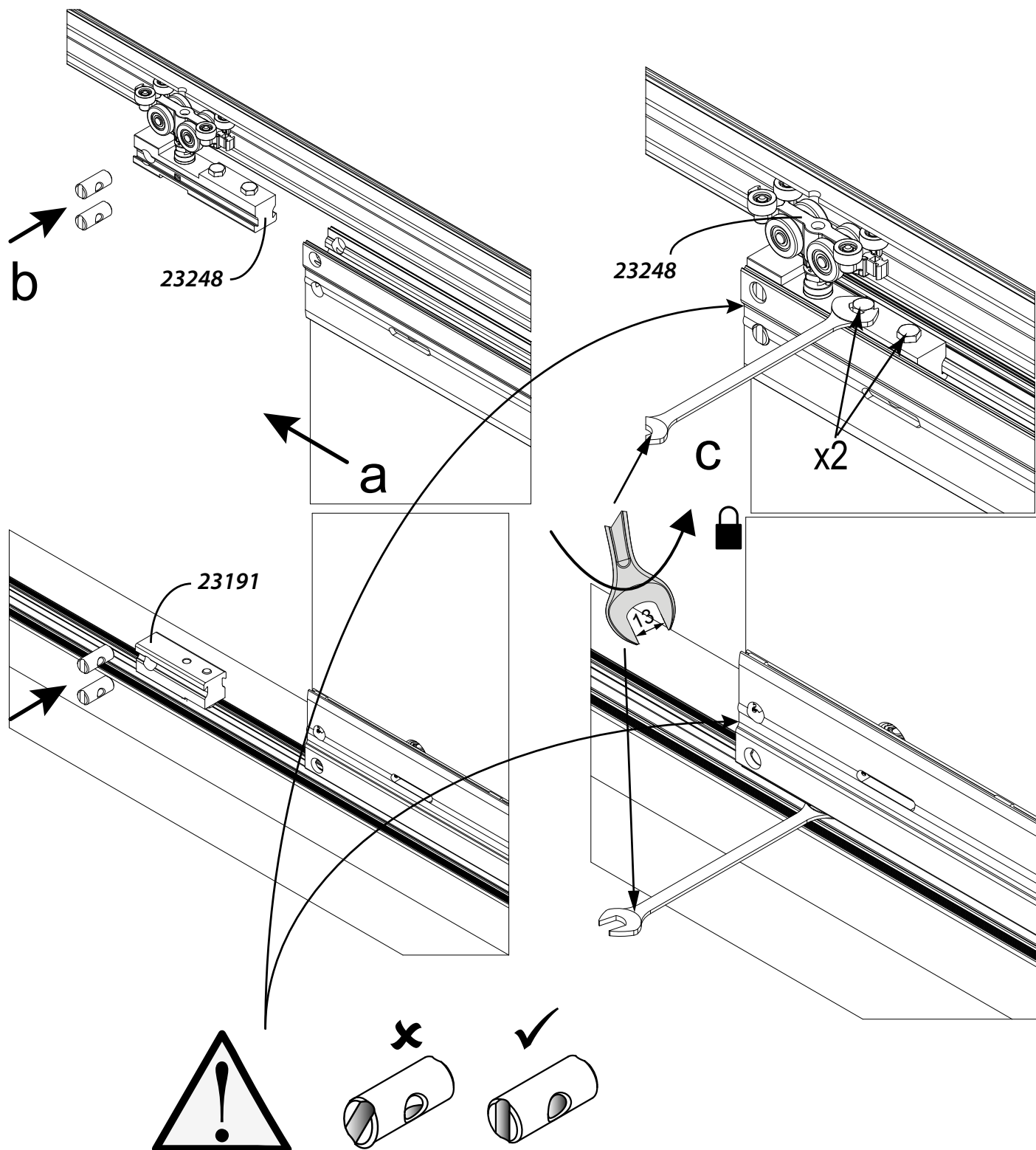

Montage des charnières - Assembly of hinges
Montage der Scharniere - Montaje de las bisagras

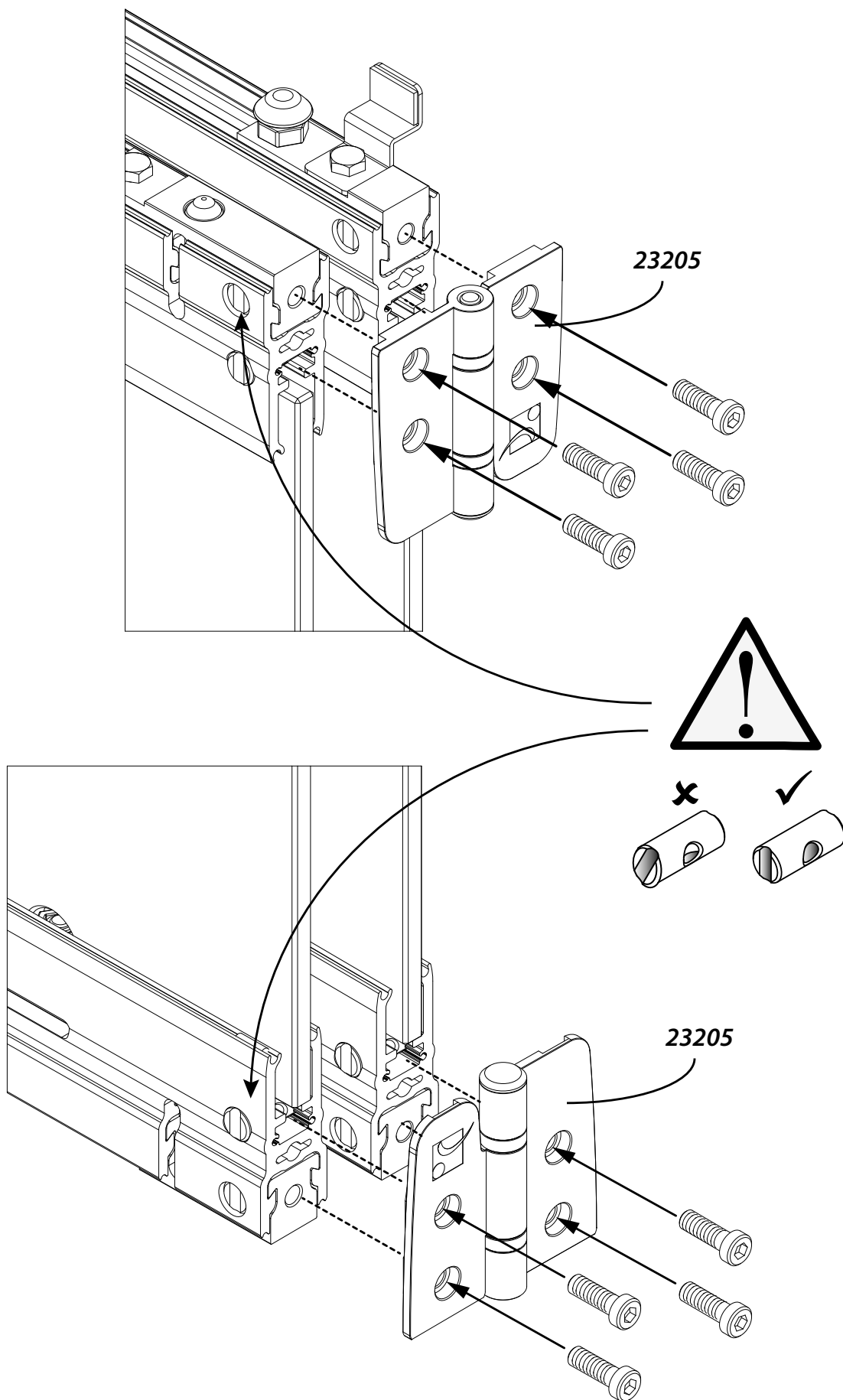

Réglages - Adjustments - Einstellung - Ajuste

