

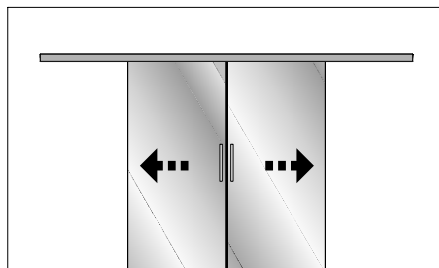

INSTRUCTION DE MONTAGE  
MONTAGEANLEITUNG  
INSTRUCTIONS FOR ASSEMBLY  
INSTRUCCIONES DE MONTAJE

**INTEC**  
NM\_INTEC\_003

PORTE D'INTÉRIEUR / INNENTÜR / INTERIOR DOOR / PUERTA DE INTERIOR

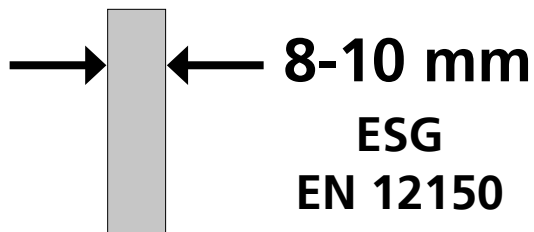

synchronisé - synchronized

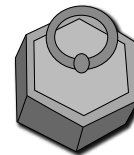

**80 KG**



# COMPOSITION - ZUSAMMENSETZUNG - COMPOSICIÓN

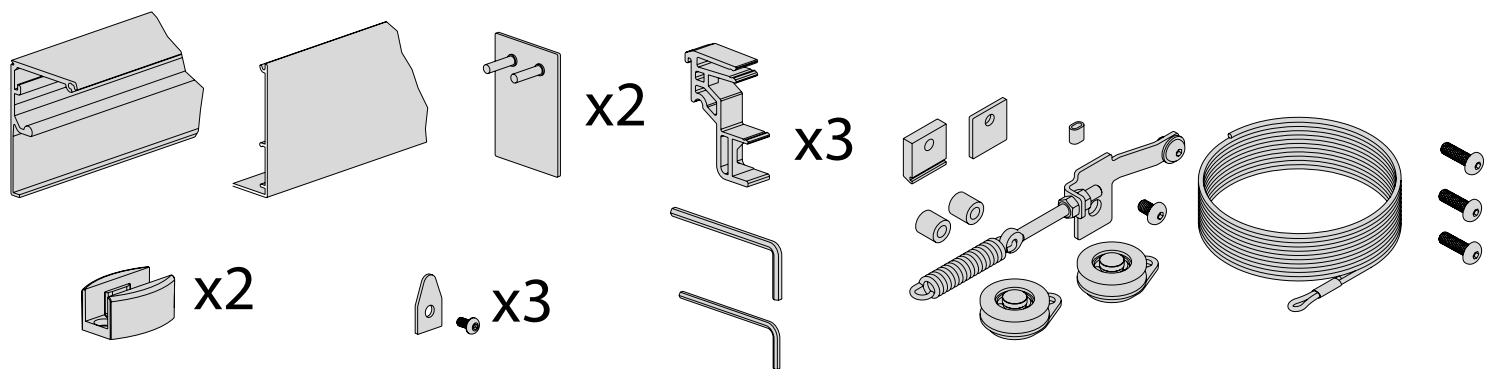

**GB 5002 - GB5004**

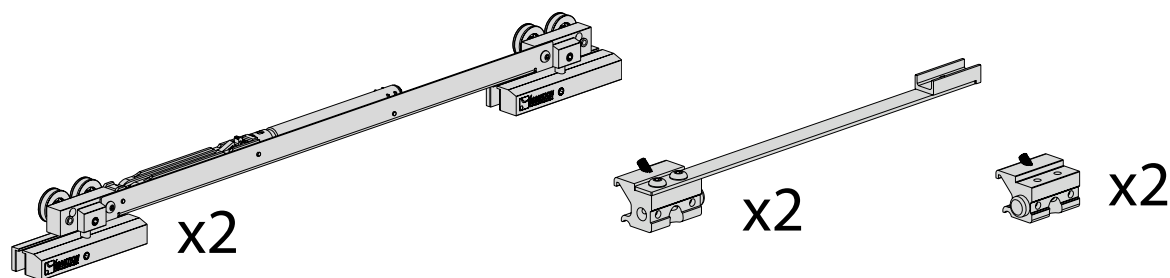

**GB 5003**

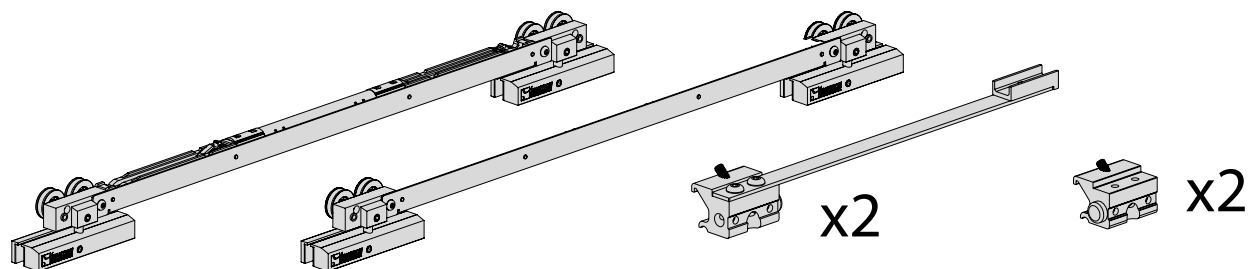

**OPTION**

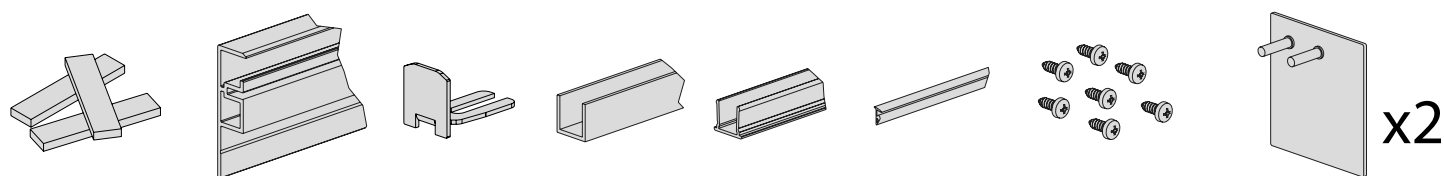

## CONDITIONS DE POSE / MONTAGEBEDINGUNGEN / INSTALLATION REQUIREMENTS / CONDICIONES DE COLOCACION:

- Produit destiné à une utilisation en intérieur / Dieses Produkt ist nur für Innenanwendung geeignet / For indoor use only / Producto para utilización en interior
- Ne pas installer dans des endroits humides / Nicht in feuchten Atmosphären verwenden / Do not install in humid places / No instalar en lugares húmedos
- Le montage doit être effectué par des monteurs qualifiés / Die Montage muss von qualifizierten Handwerkern geführt werden / Installation must be performed by skilled personnel / el montaje tiene que hacerse por instaladores cualificados

## DIMENSIONS / MASSE / SIZING / DIMENSIONES (mm):

Lintheu min. / Min. Türsturz / Min. lintel / Dintel min: **71 mm**

Epaisseur panneau / Paneelstärke / Panel thickness / Grueso del panel: **8-10 mm (ESG - EN12150)**

Poids panneau / Paneelgewicht / Panel weight / Peso panel: **80 Kg MAX**

Largeur de panneau minimum / Minimale Feldbreite / Minimum panel width / Ancho del panel mínimo: **710 mm**

# ENCOMBREMMENT - ABMESSUNGEN - DIMENSIONS - VOLUMEN

## FIXATION MURALE FIXING ON THE WALL WANDBEFESTIGUNG MONTAJE FIJACIÓN A PARED

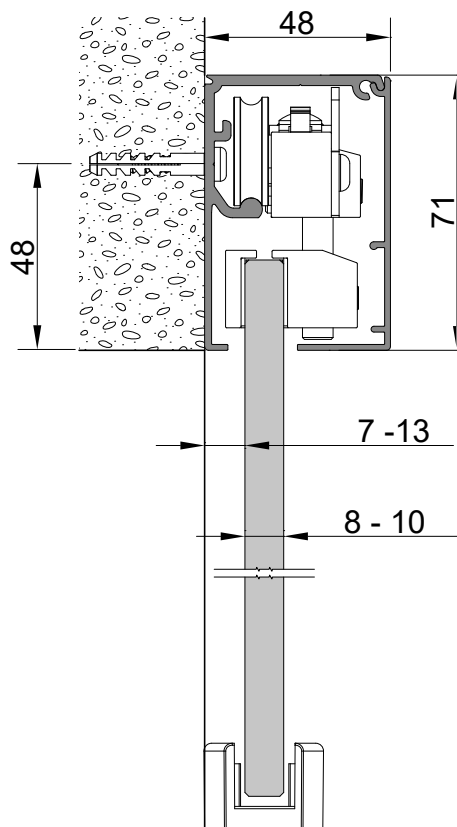

Réf. Kit Set nb / Art.-Nr.	O	R
GB0110	$1330 \leq O < 1530$	$(3004 - O) / 2$
GB0112	$1530 \leq O < 1730$	$(3404 - O) / 2$
GB0114	$1730 \leq O < 1930$	$(3804 - O) / 2$
GB0116	$1930 \leq O < 2130$	$(4204 - O) / 2$
GB0118	$2130 \leq O < 2330$	$(4604 - O) / 2$
GB0120	$2330 \leq O < 2530$	$(5004 - O) / 2$

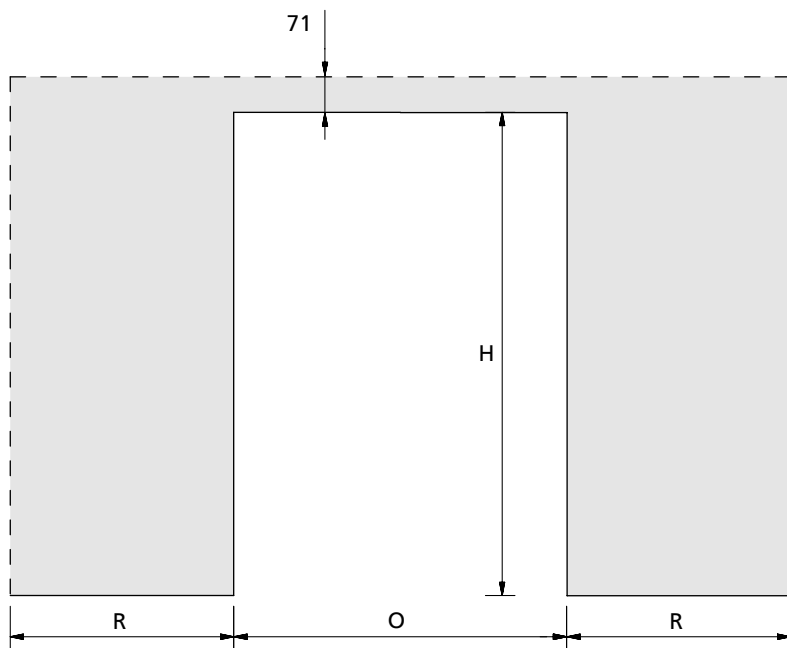

Dimensions de la porte - Abmessungen von Türen - Dimensions of doors - Dimensiones de las puertas

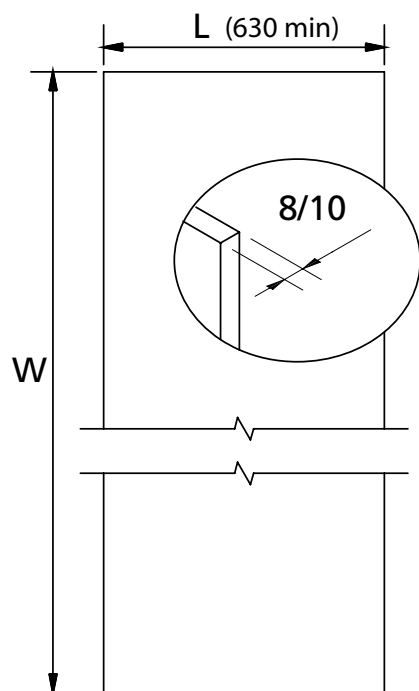

ESG  
EN 12150

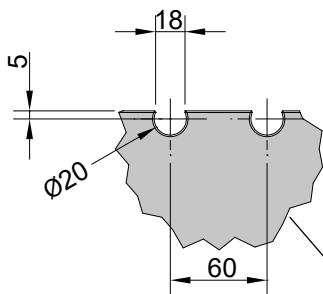

Réf. Kit Set nb / Art.-Nr.	L	W	B
GB0110	$(O / 2) + 42$	$H + 15$	450
GB0112	$(O / 2) + 42$	$H + 15$	540
GB0114	$(O / 2) + 42$	$H + 15$	660
GB0116	$(O / 2) + 42$	$H + 15$	660
GB0118	$(O / 2) + 42$	$H + 15$	660
GB0120	$(O / 2) + 42$	$H + 15$	660

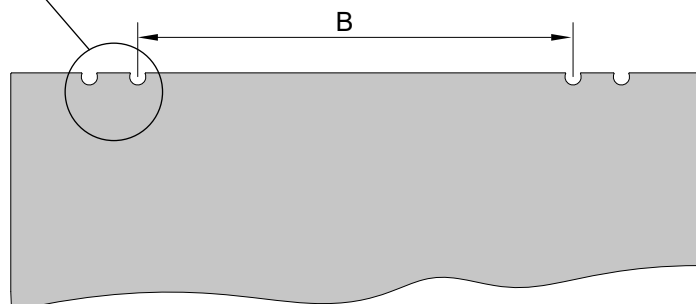

## FIXATION AU PLAFOND FIXING ON THE CEILING DECKENBEFESTIGUNG MONTAJE FIJACIÓN AL TECHO

Réf. Kit Set nb / Art.-Nr.	O	R
GB0110	$1330 \leq O < 1530$	$(3004 - O) / 2$
GB0112	$1530 \leq O < 1730$	$(3404 - O) / 2$
GB0114	$1730 \leq O < 1930$	$(3804 - O) / 2$
GB0116	$1930 \leq O < 2130$	$(4204 - O) / 2$
GB0118	$2130 \leq O < 2330$	$(4604 - O) / 2$
GB0120	$2330 \leq O < 2530$	$(5004 - O) / 2$

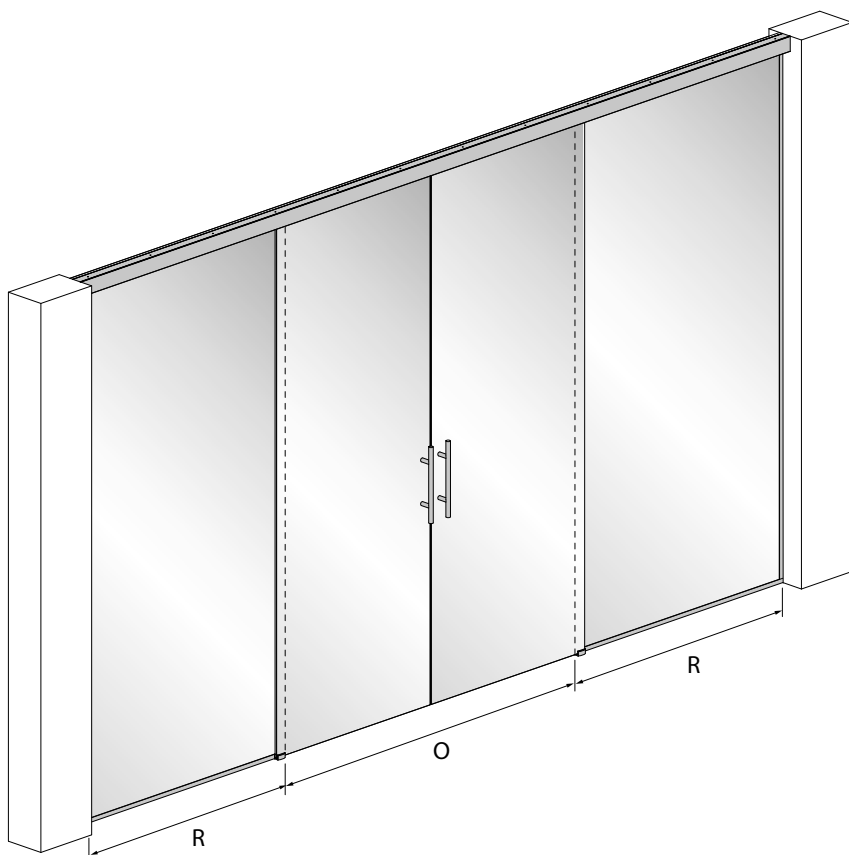
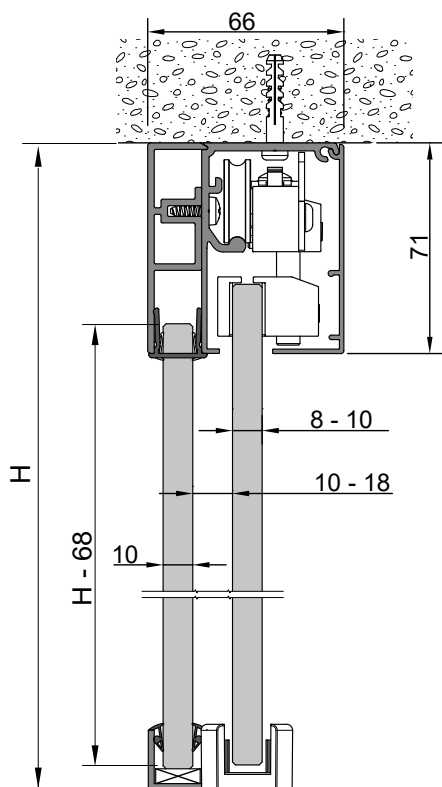
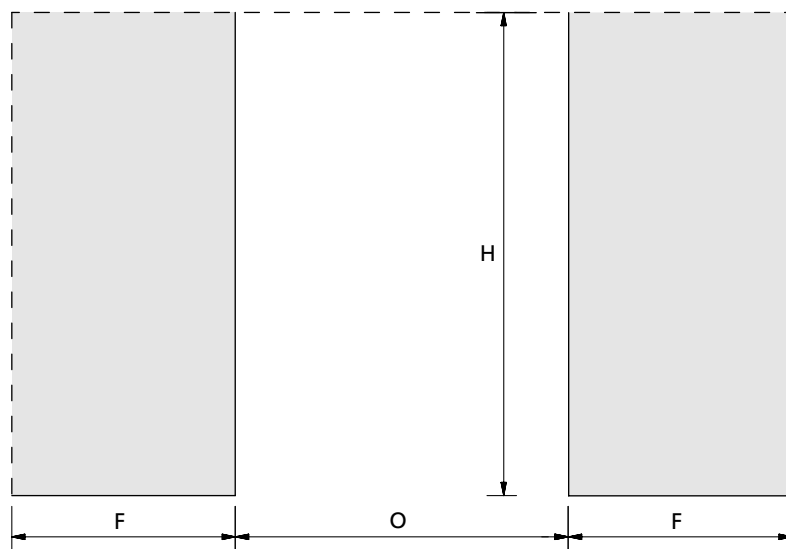
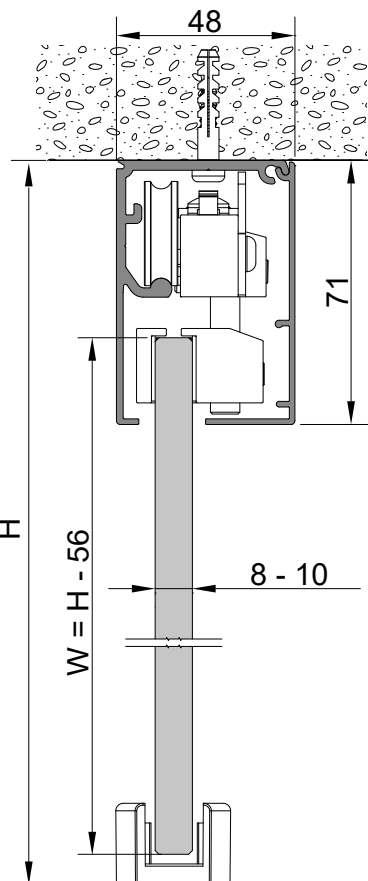

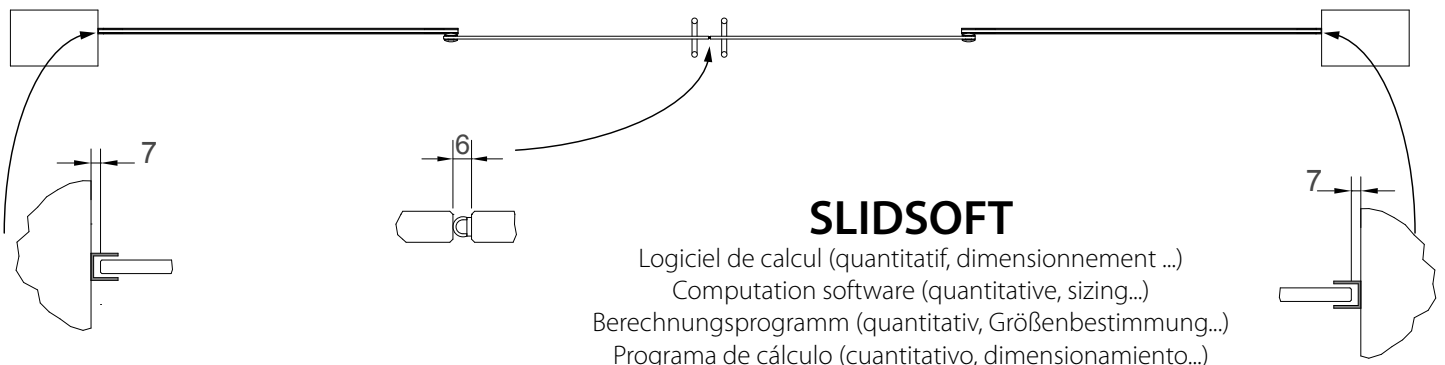
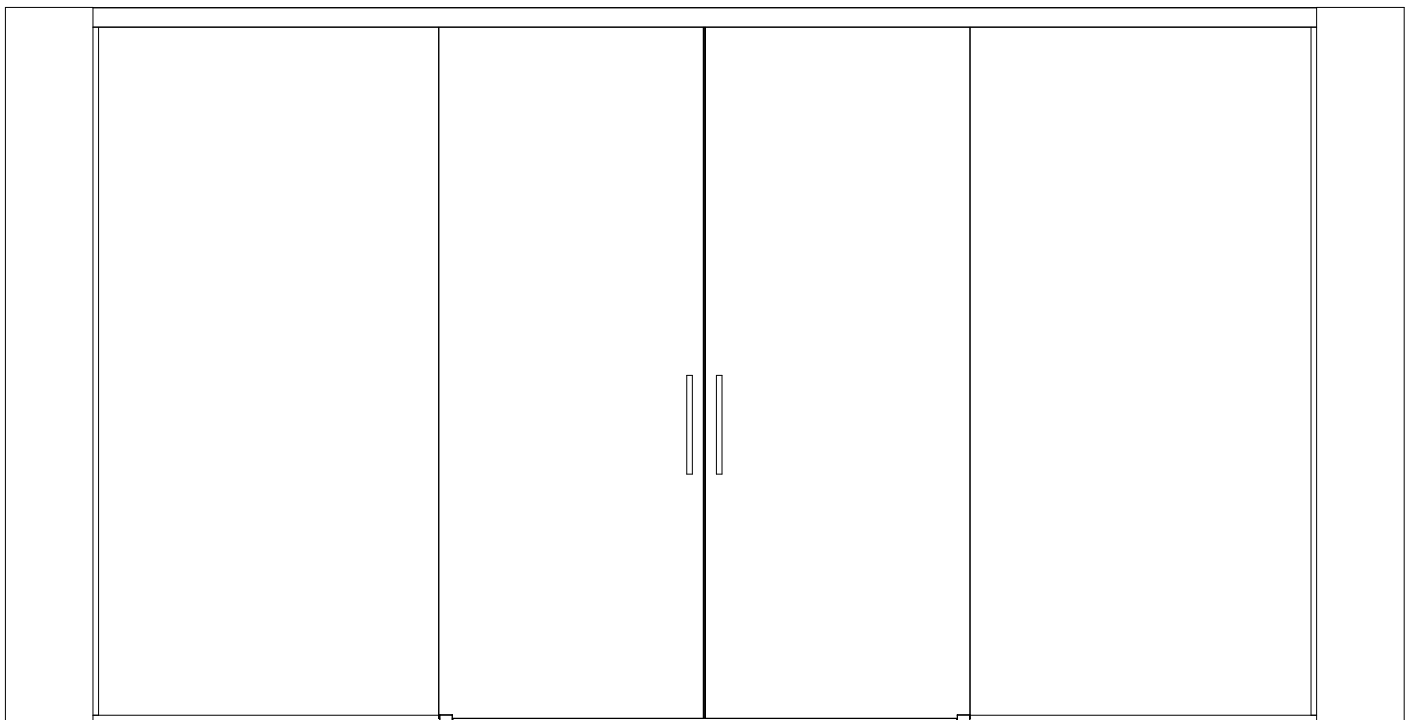
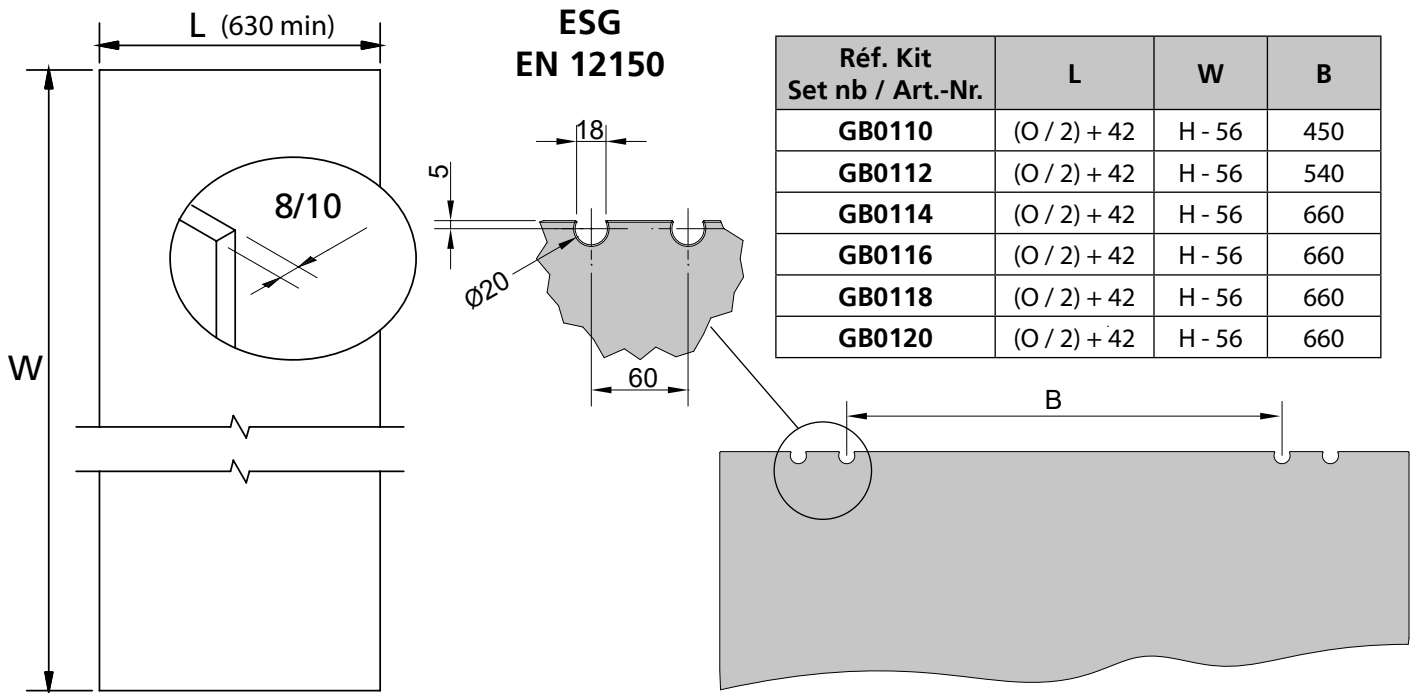

[www.mantion.com](http://www.mantion.com)

1.

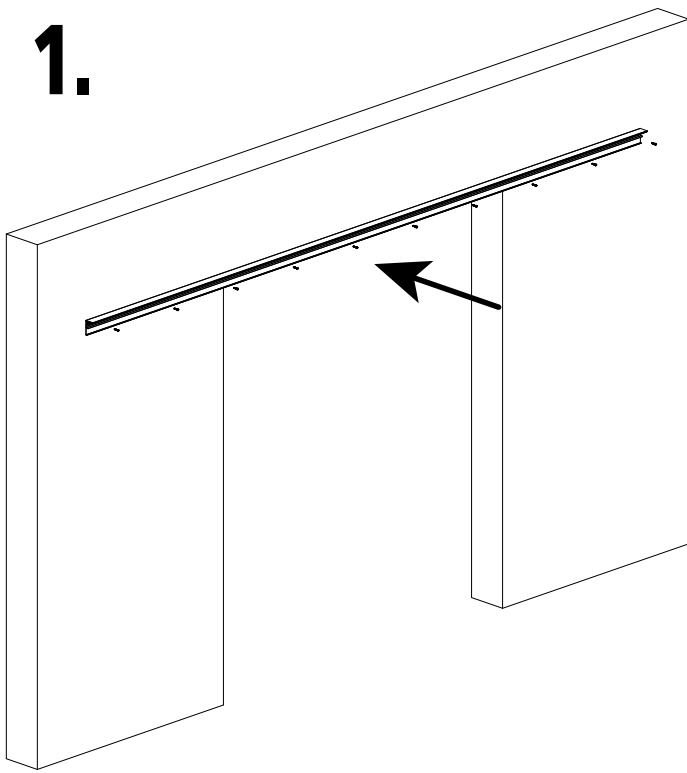

OU  
OR  
ODER

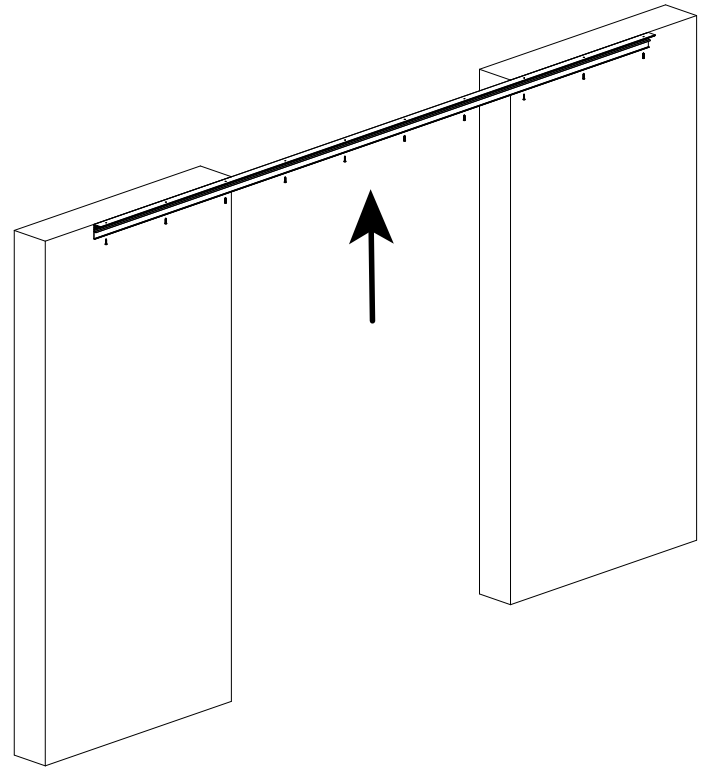

# 1.bis - OPTION

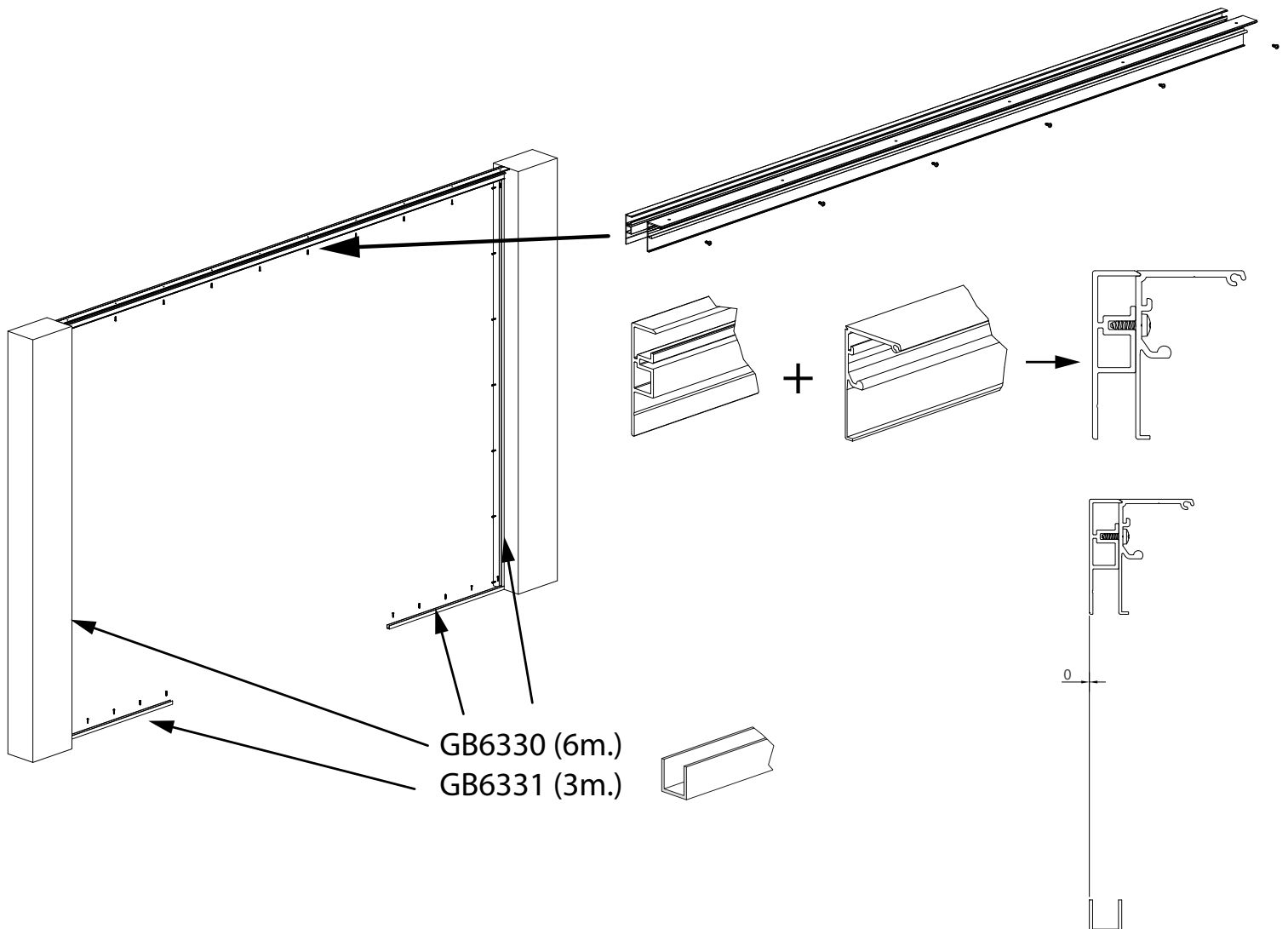

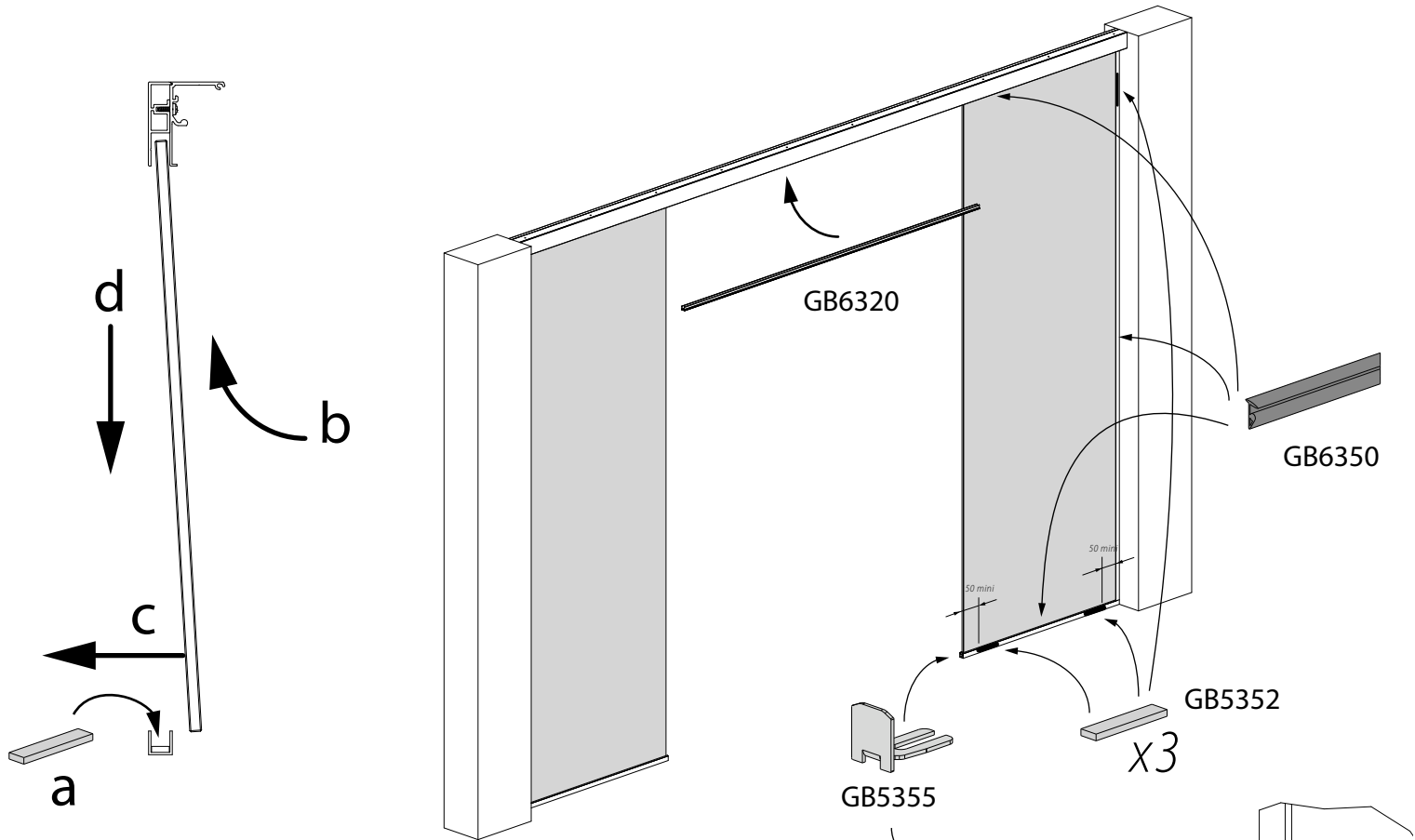

**2.**

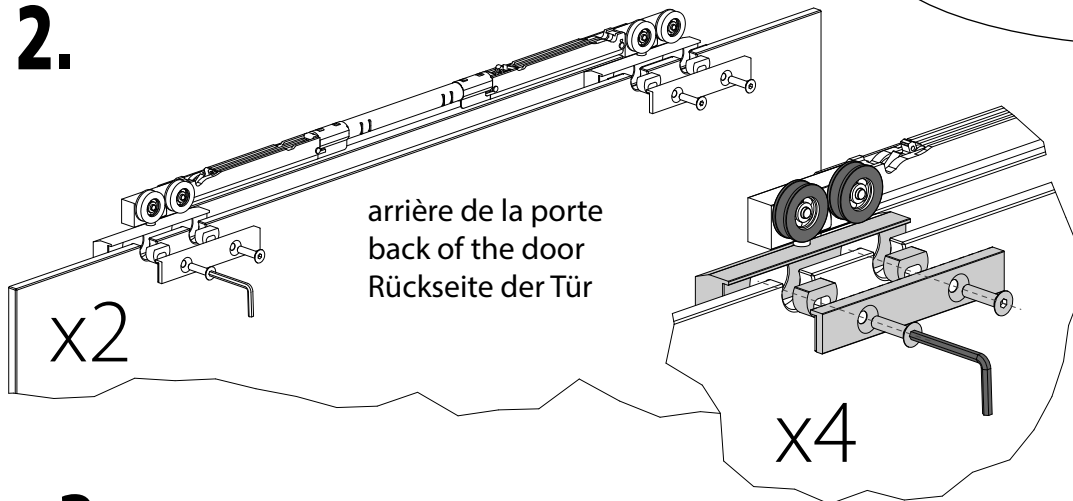

**3.**

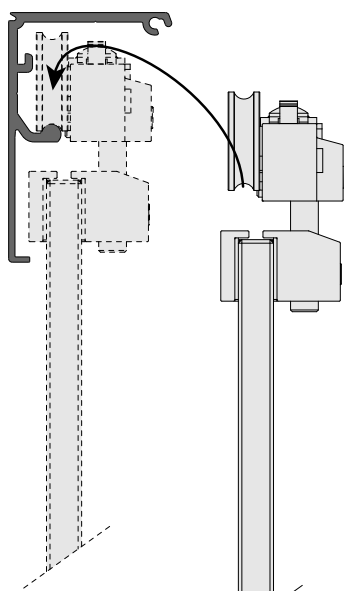

**4.**

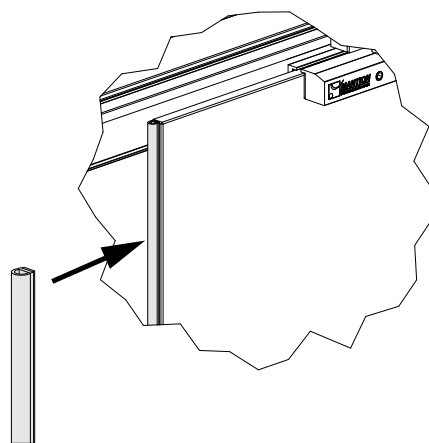

**5.**

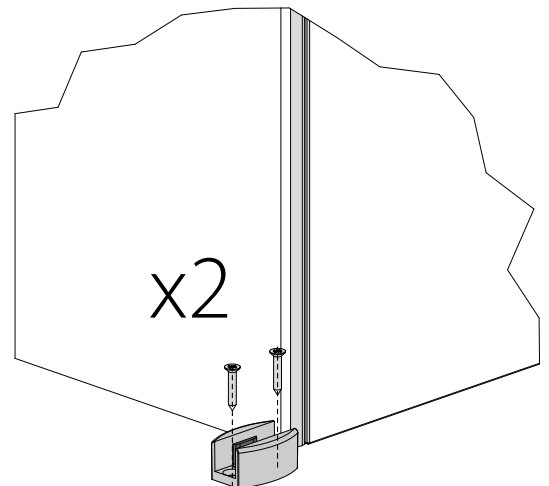

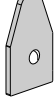
6.  x4

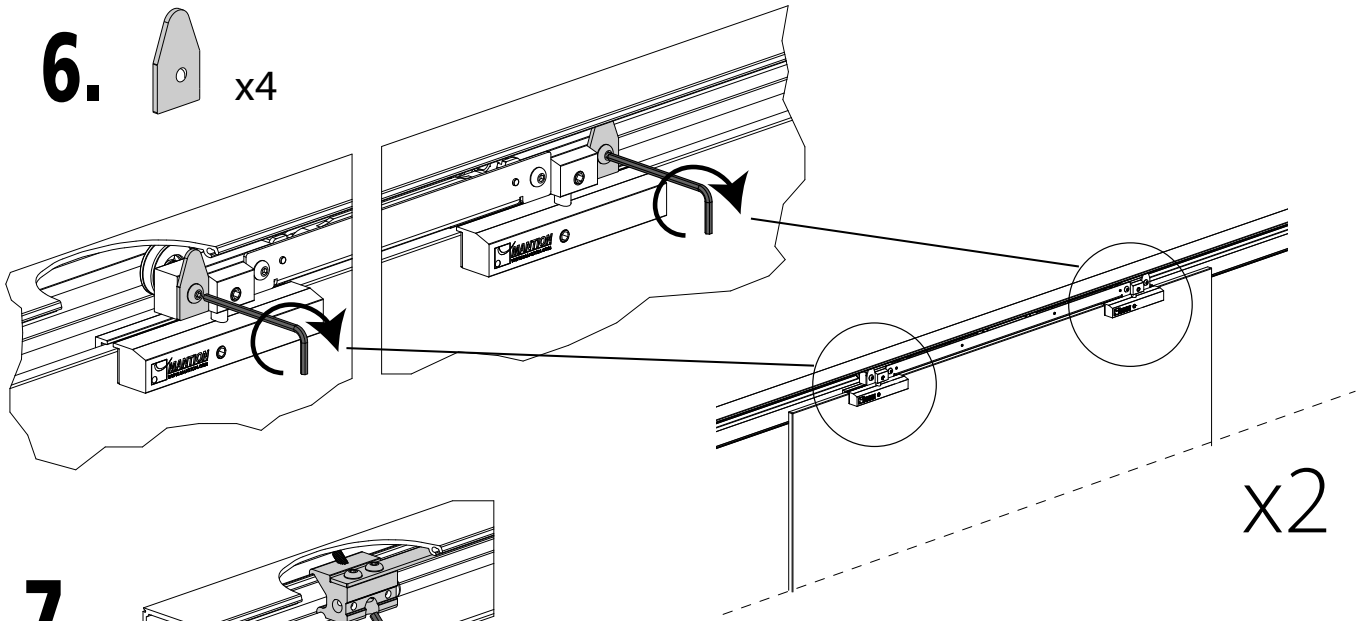

7.

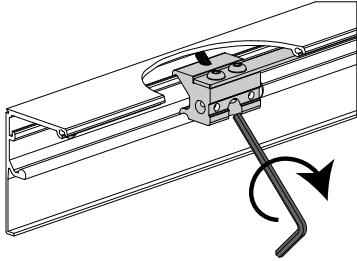

GB5002 & GB5004

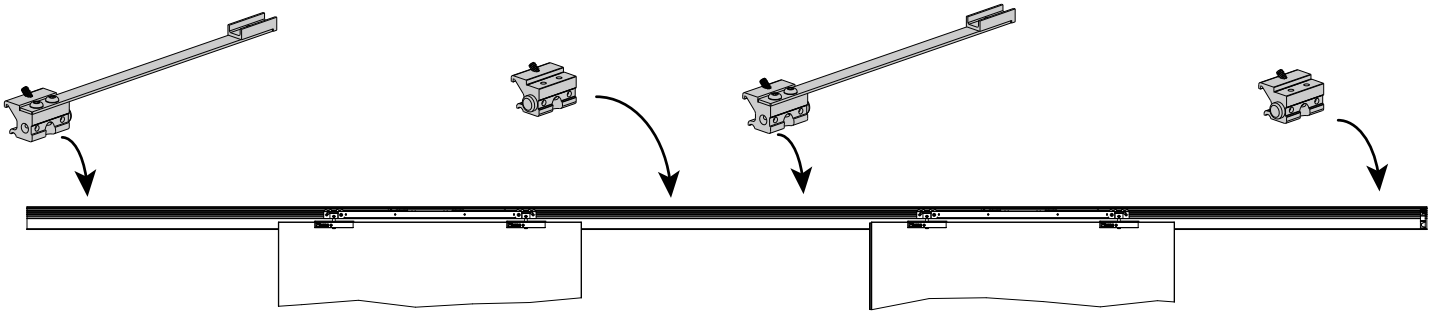

GB5003

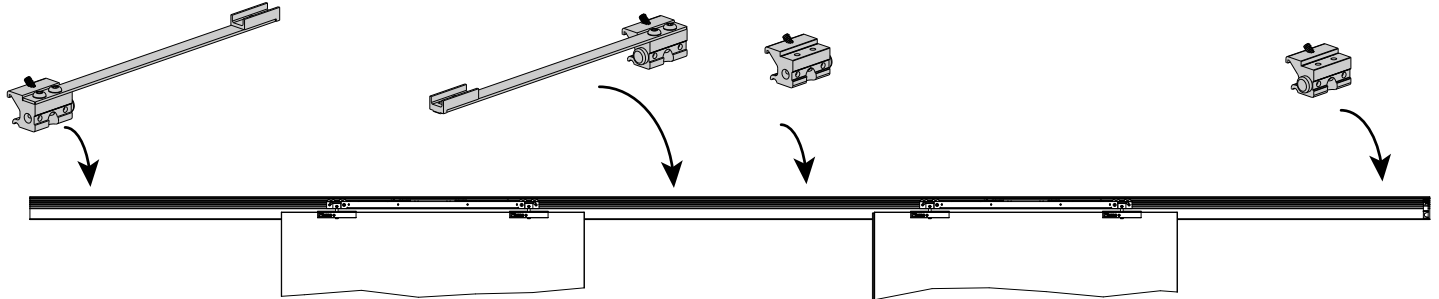

8.

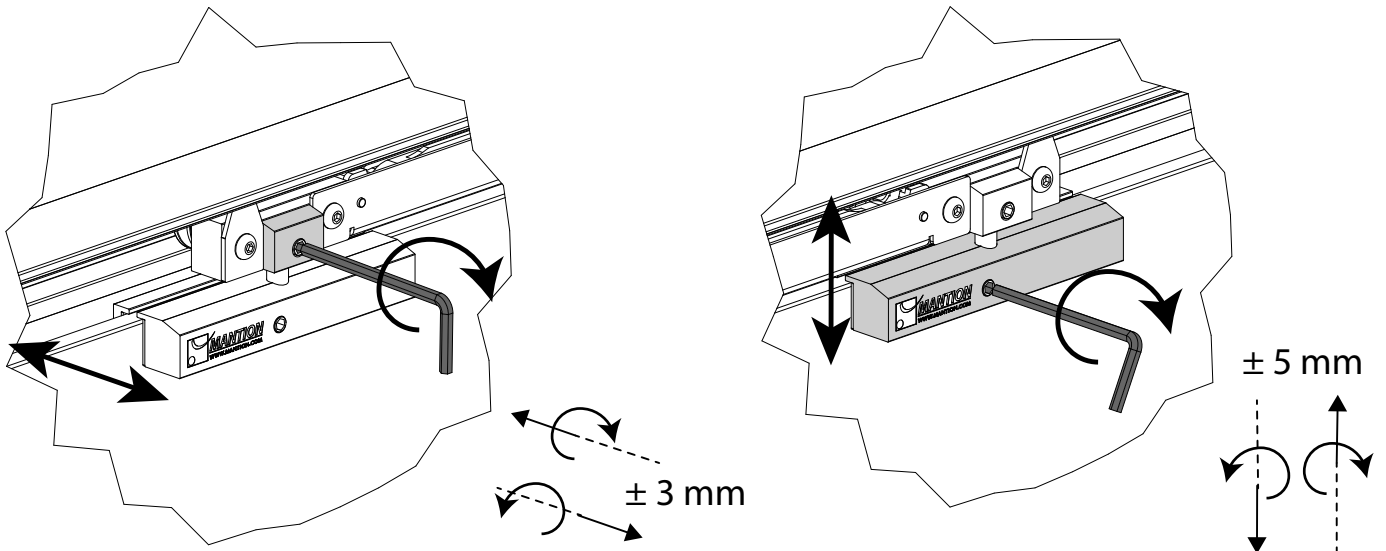

9.

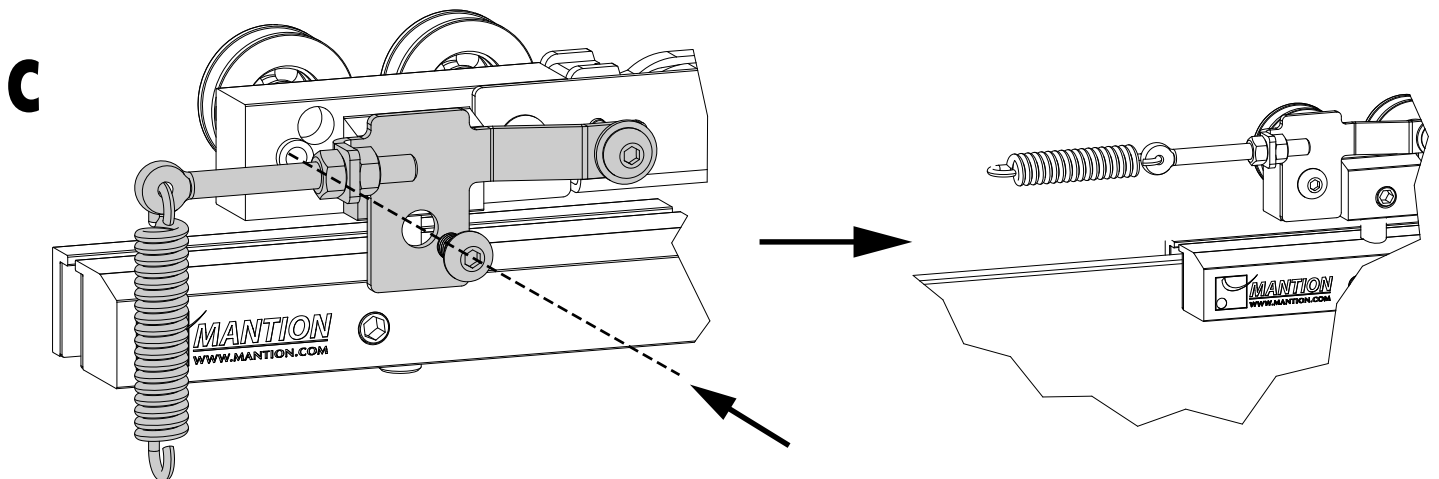
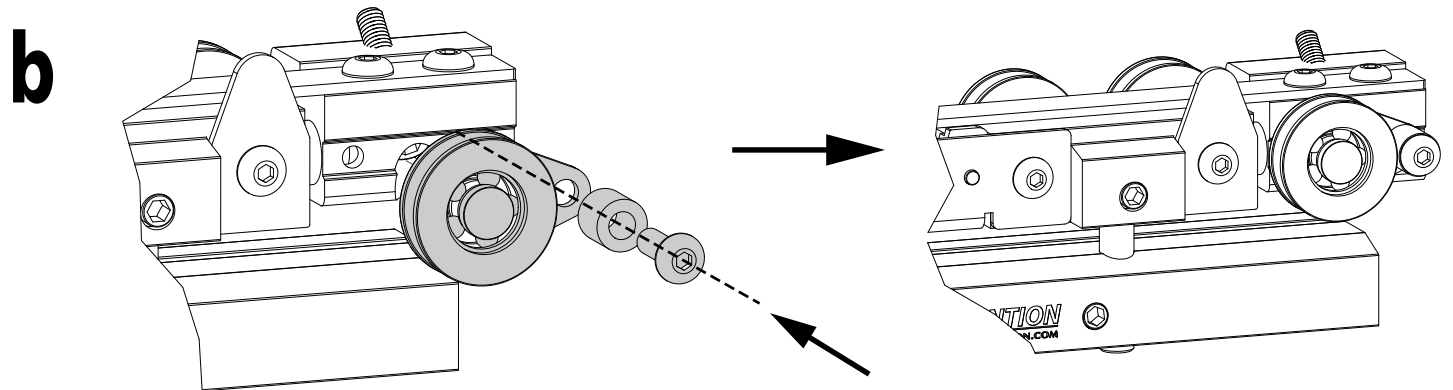
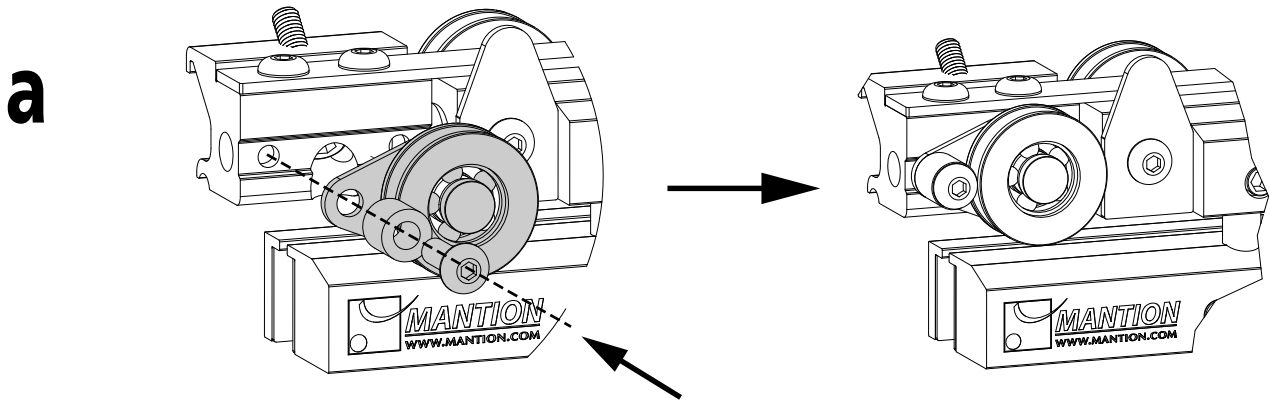
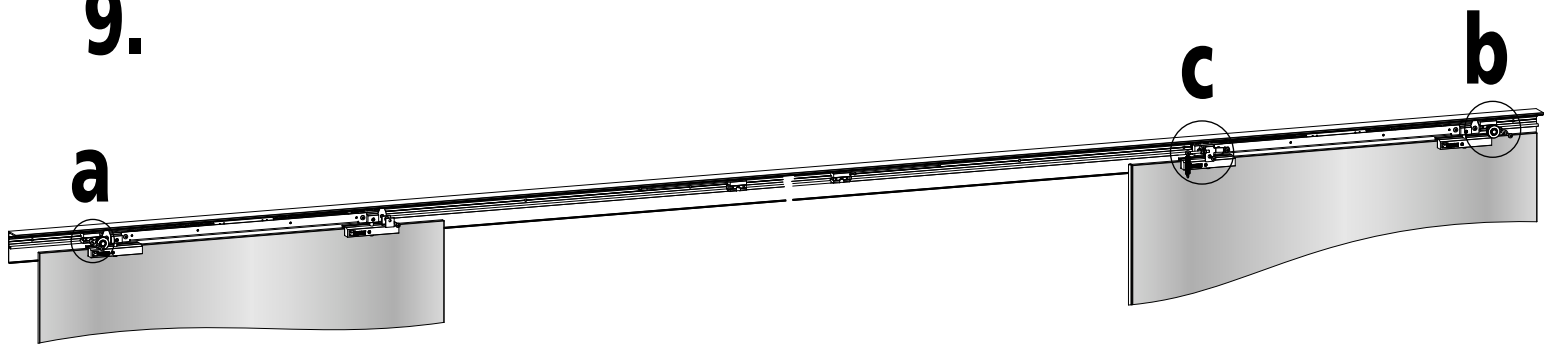

10.

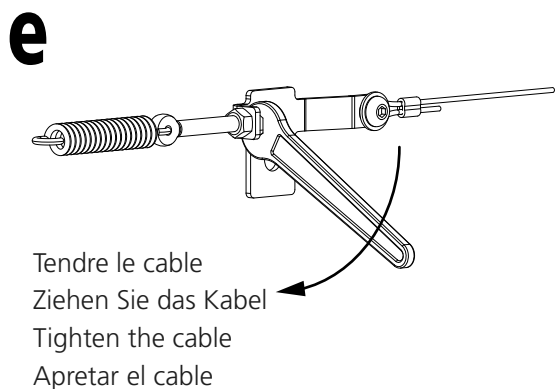
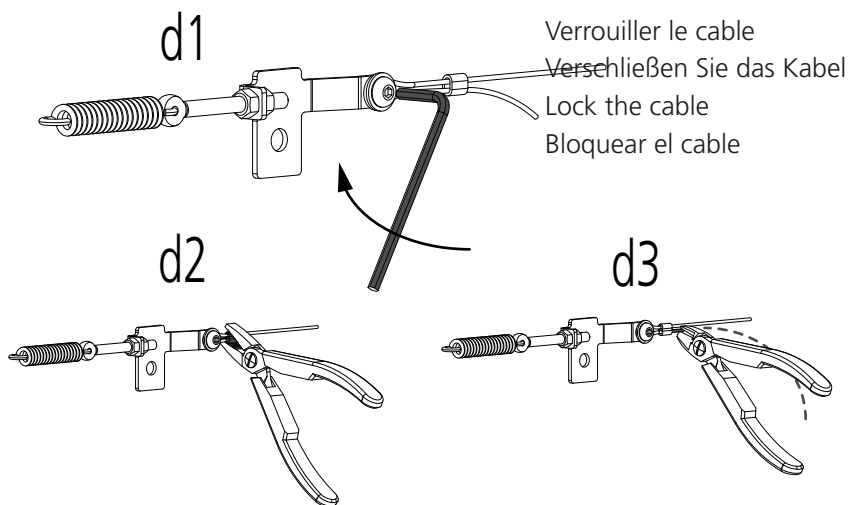
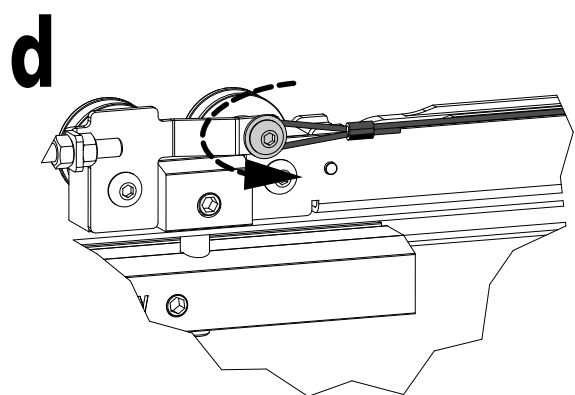
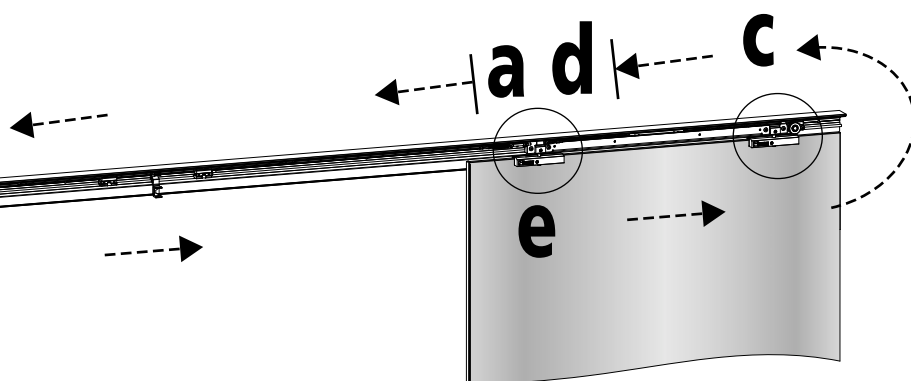
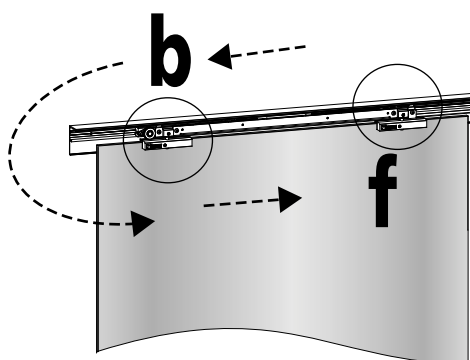
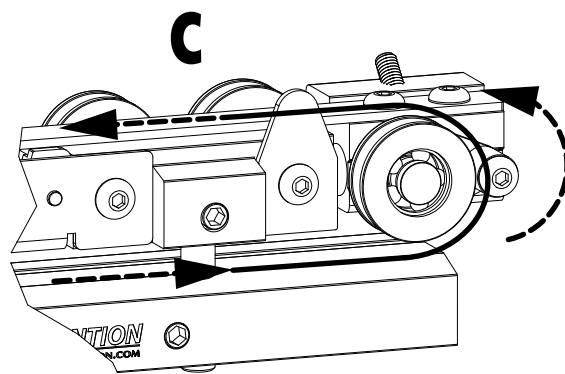
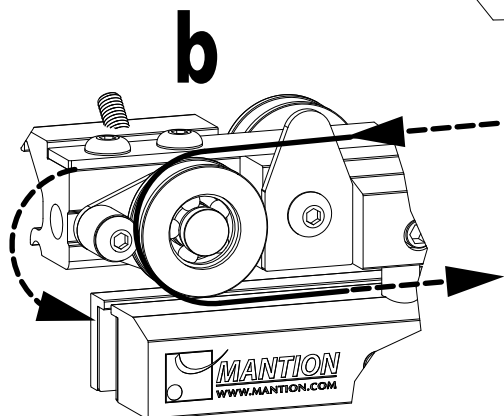
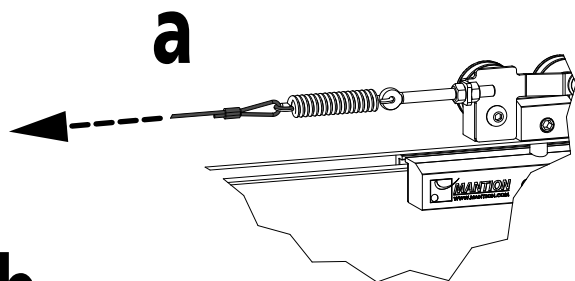

Verrouiller le cable lorsque les panneaux sont en position ouverte  
Verriegeln wenn die flügel geöffnet sind  
Lock when the panels are open  
Bloquear el cable cuando las hojas están en posición abierta

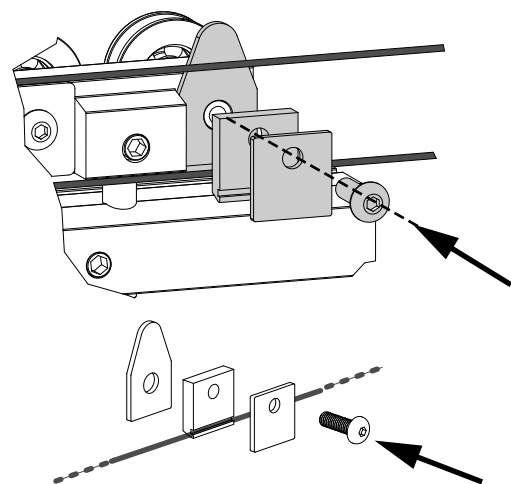

# 11.

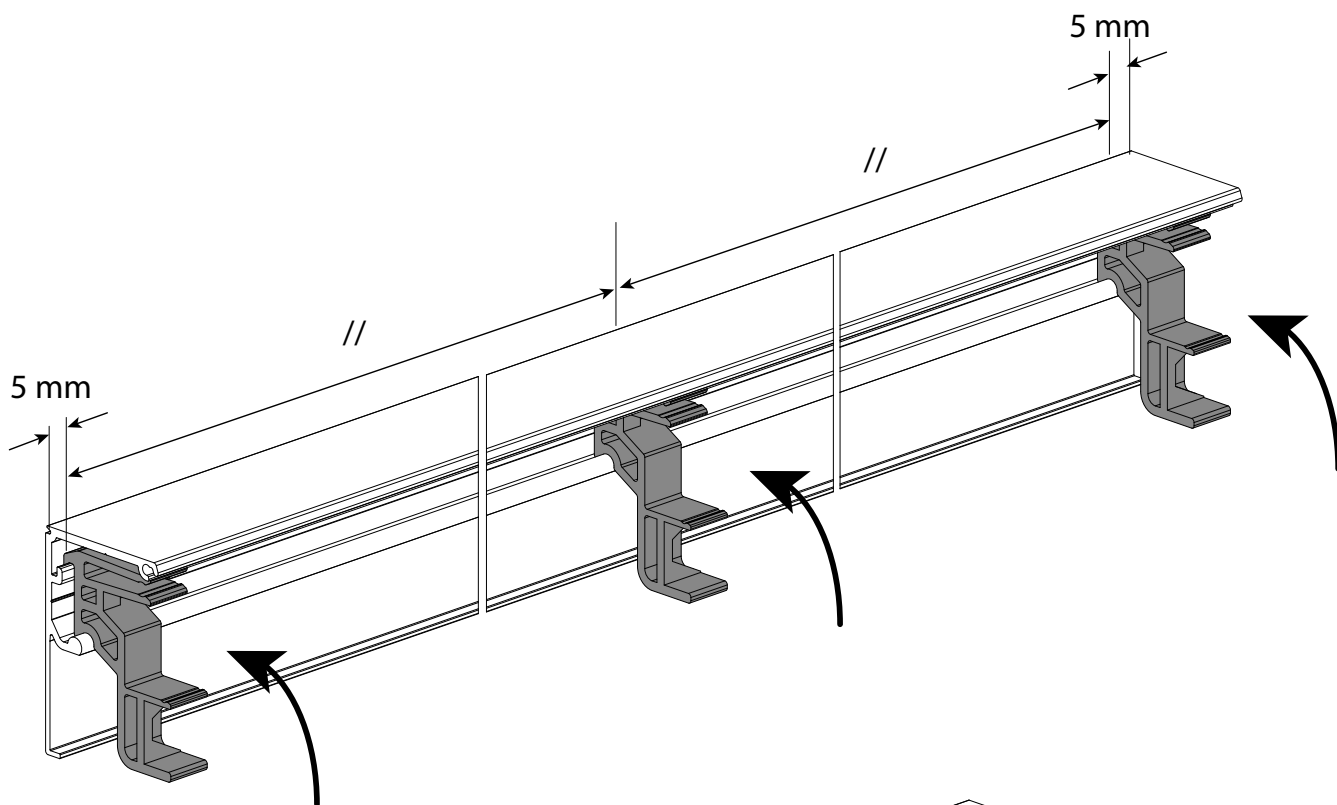

# 12.

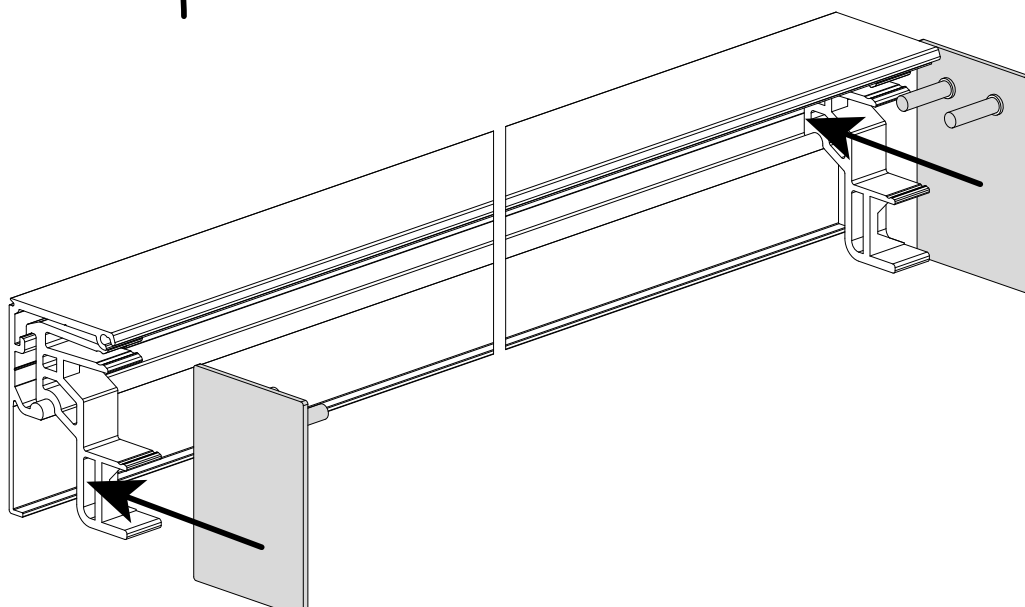

# 13.

