

Material/Matière:  
Aluminium anodized  
Aluminium anodisé

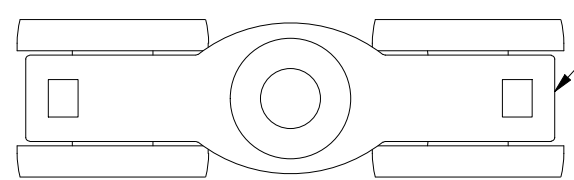

Material/Matière:  
PA 6 GF30  
PA 6 + 30% fibre de verre

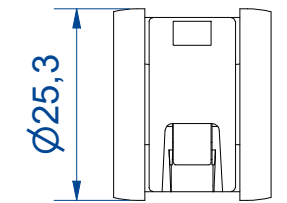
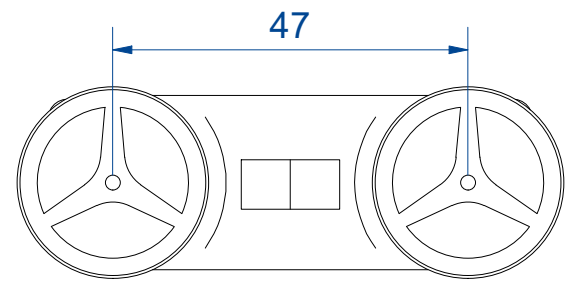
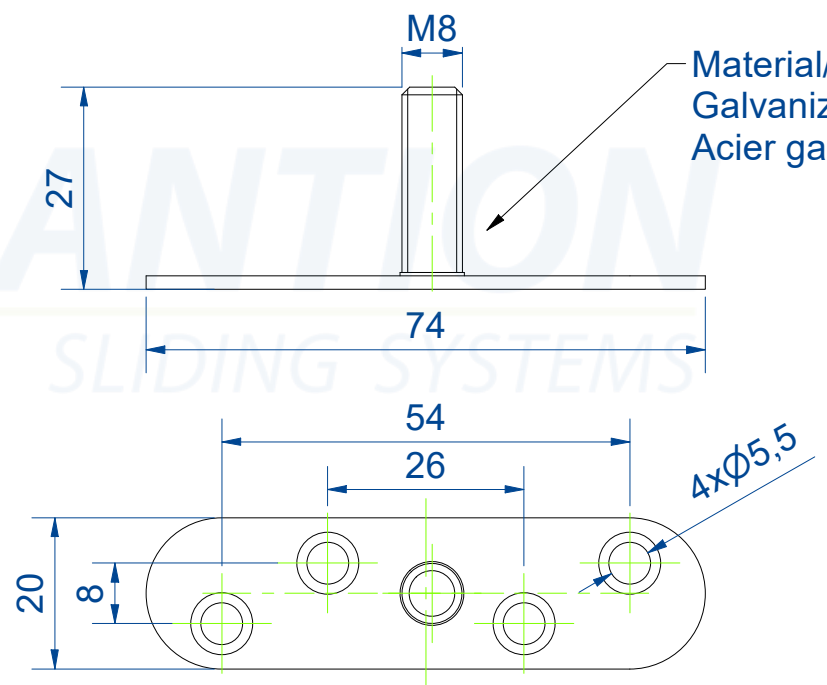
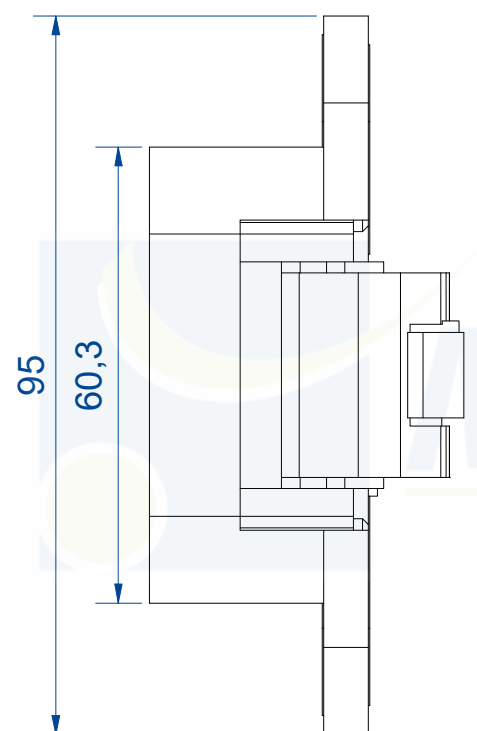
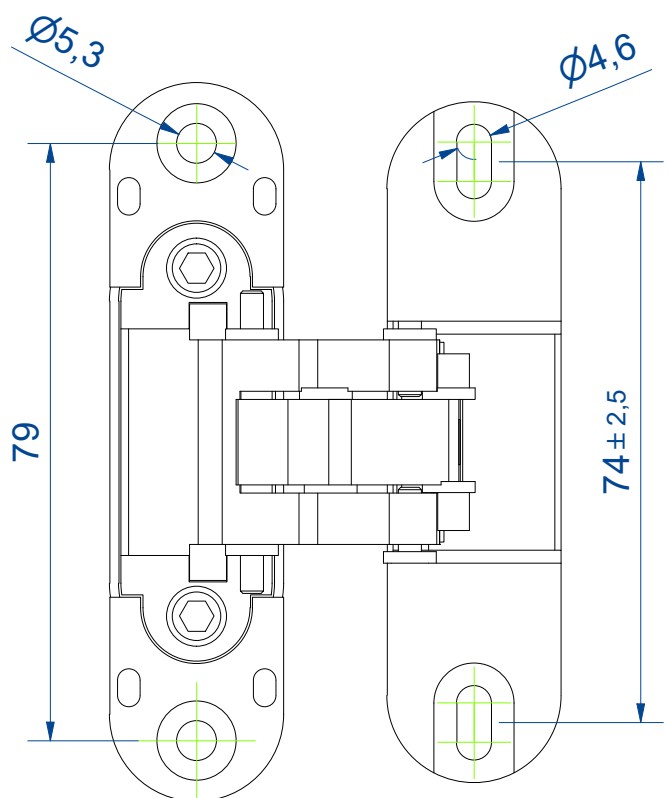

Material/Matière:  
Galvanized steel  
Acier galvanisé

- Capacité: Porte 80kg max.
- 1 rail 13108 L1400mm
  - 1 montures ( axes sur RLts a billes)
  - 1 platine ref 12036Z
  - 6 charnières invisibles 3D 1540
  - 1 Gabarit
  - Visserie et outils

- Capacity : Doors 80kg max.
- 1 track 13108 L1400mm
  - 1 hangers (with ball bearings)
  - 1 plates 12036Z
  - 6 3D adjustable hinges 1540
  - 1 jig
  - Screws and tools

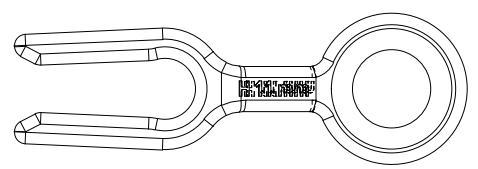
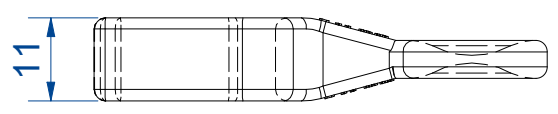

**MANTION**  
SYSTÈMES COULISSANTS  
7,rue Gay Lussac  
25000 BESANCON

Référence  
Item Nr:  
**SFOLD80-140-1**

Range:  
**13108**