

- Garniture pour une porte coulissante à 2 panneaux verre synchronisés
 Epaisseur verre : 8 mm
 Poids : 2x80 Kg MAX
 Largeur baie : 2,2 m MAX
 Contenu :
- 4 montres (mouvement sur roulements à billes)
 - 6 pinces en aluminium anodisé
 - 1 butée réf. 11213N
 - 1 butée simple pour synchronisation
 - 1 ferme-porte réf. M66
 - 1 ferme-porte pour synchronisation
 - 2 guides réf. 1112/4
 - 3 supports de câble
 - 1 câble acier de synchronisation longueur 10 m
 - 1 niveau à bulle "Buly®"

- Gear kit for 2-synchronized-glass-leaf sliding door
 Glass thickness = 8 mm
 MAX load = 2x40 Kg
 MAX opening length = 2,2 m
 Content :
- 4 hangers (ball bearings movement)
 - 6 anodised aluminium clamps
 - 1 stopper item n° 11213N
 - 1 stopper for synchronisation
 - 1 damper closer item n° M66
 - 1 damper closer for synchronisation
 - 2 guides item n° 1112/4
 - 3 brackets for rope
 - 1 câble acier de synchronisation longueur 10 m
 - 1 niveau à bulle "Buly®"

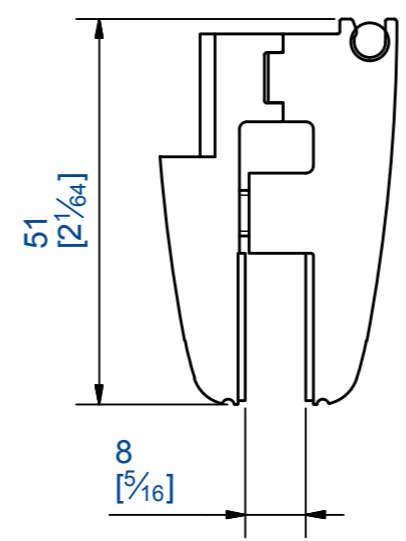
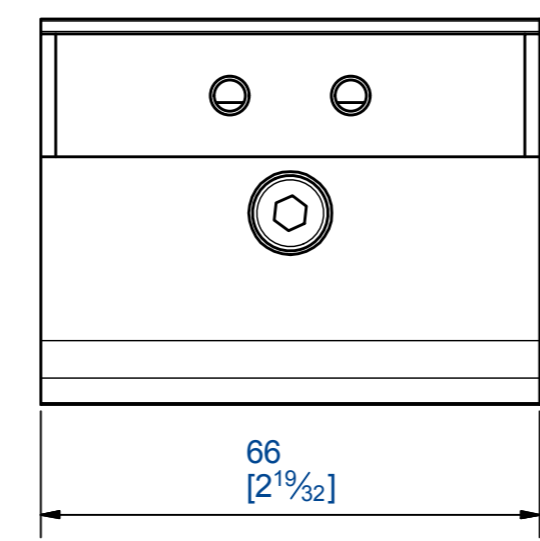
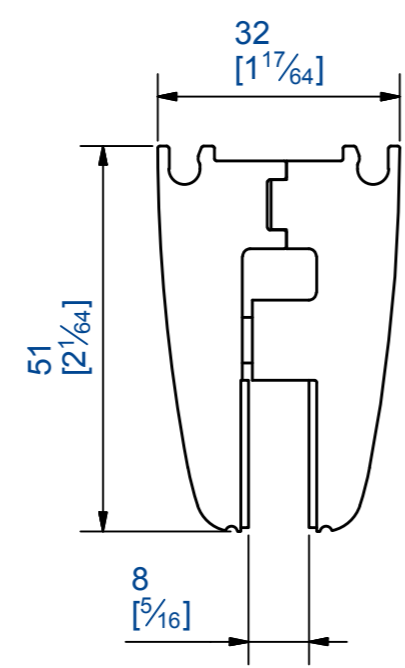
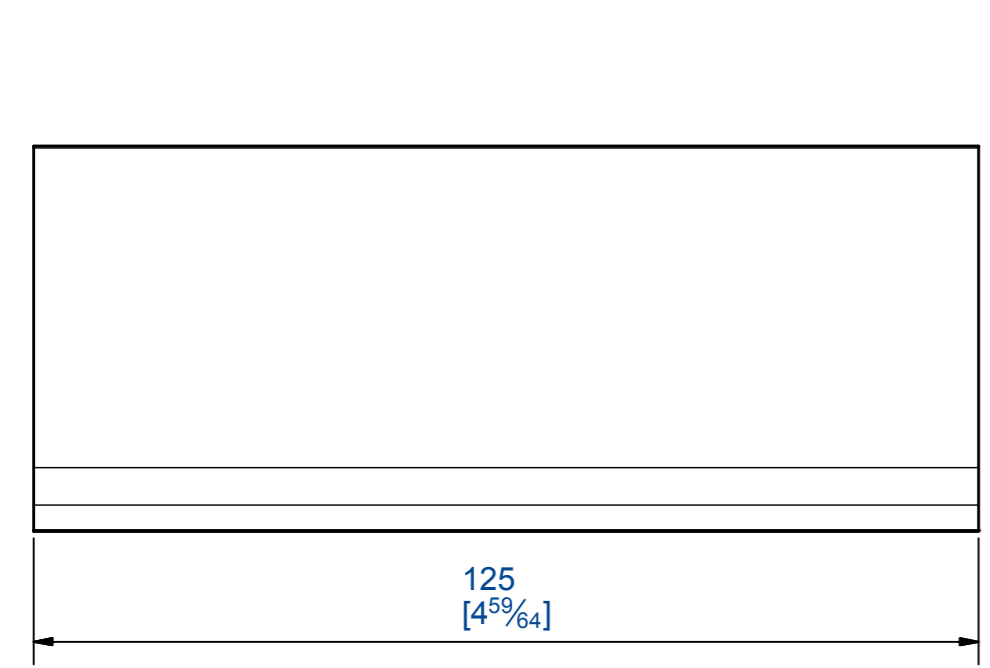

Référence Item Nr: **GA5071**

Rail associé Combined track: **11108**