

Garniture pour une porte coulissante verre de 8 mm ; poids 80 Kg MAX
 Contenu :
 - 2 montures (mouvement sur roulements à billes)
 - 2 pinces pour verre épaisseur 8 mm
 - 1 butée réf. 11213S80
 - 1 ferme porte M66
 - 1 guide réf. 1112-4
 - 1 niveau à bulle "Buly®"

Gear set for one only 8mm thick glass sliding door; MAX load = 80 Kg
 Content :
 - 2 hangers (ball bearings movement)
 - 2 clamps for 8 mm thick glass
 - 1 stopper item n° 11213S80
 - 1 damper closer item M66
 - 1 guide item n° 1112-4
 - 1 water level "Buly®"

x2

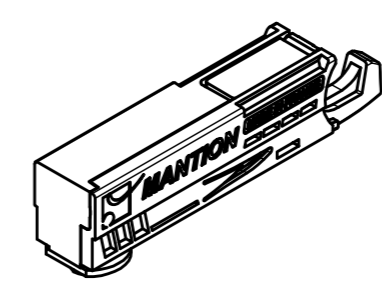
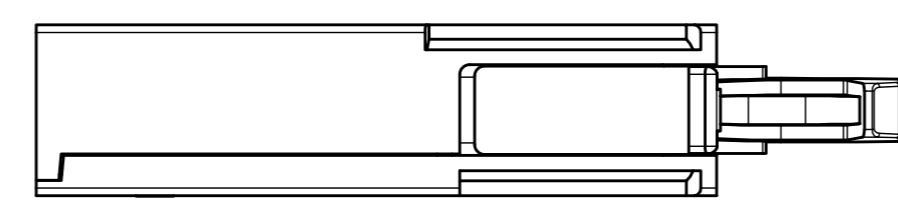
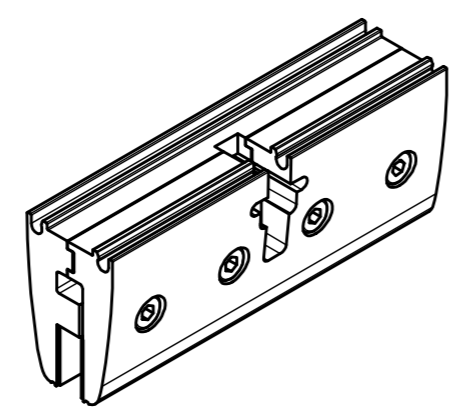
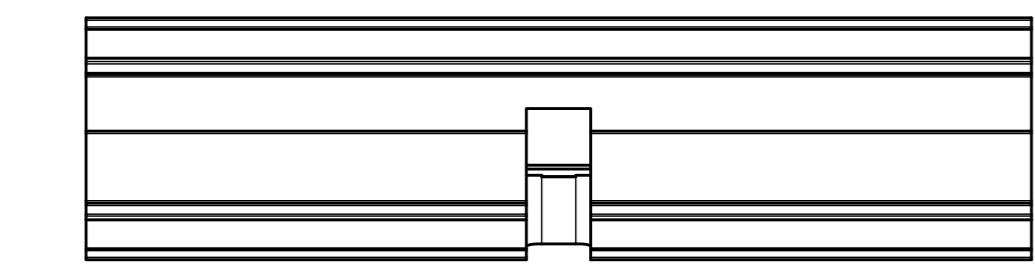

Référence Item Nr: **GA4201**

Rail associé Combined track: **11108**